

**AD1 - ITS Data Mart  
 NYSDOT Main Office Highway Data Services**

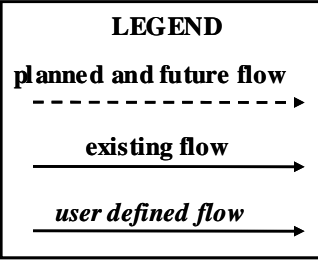

**AD1 - ITS Data Mart  
NYSDOT**

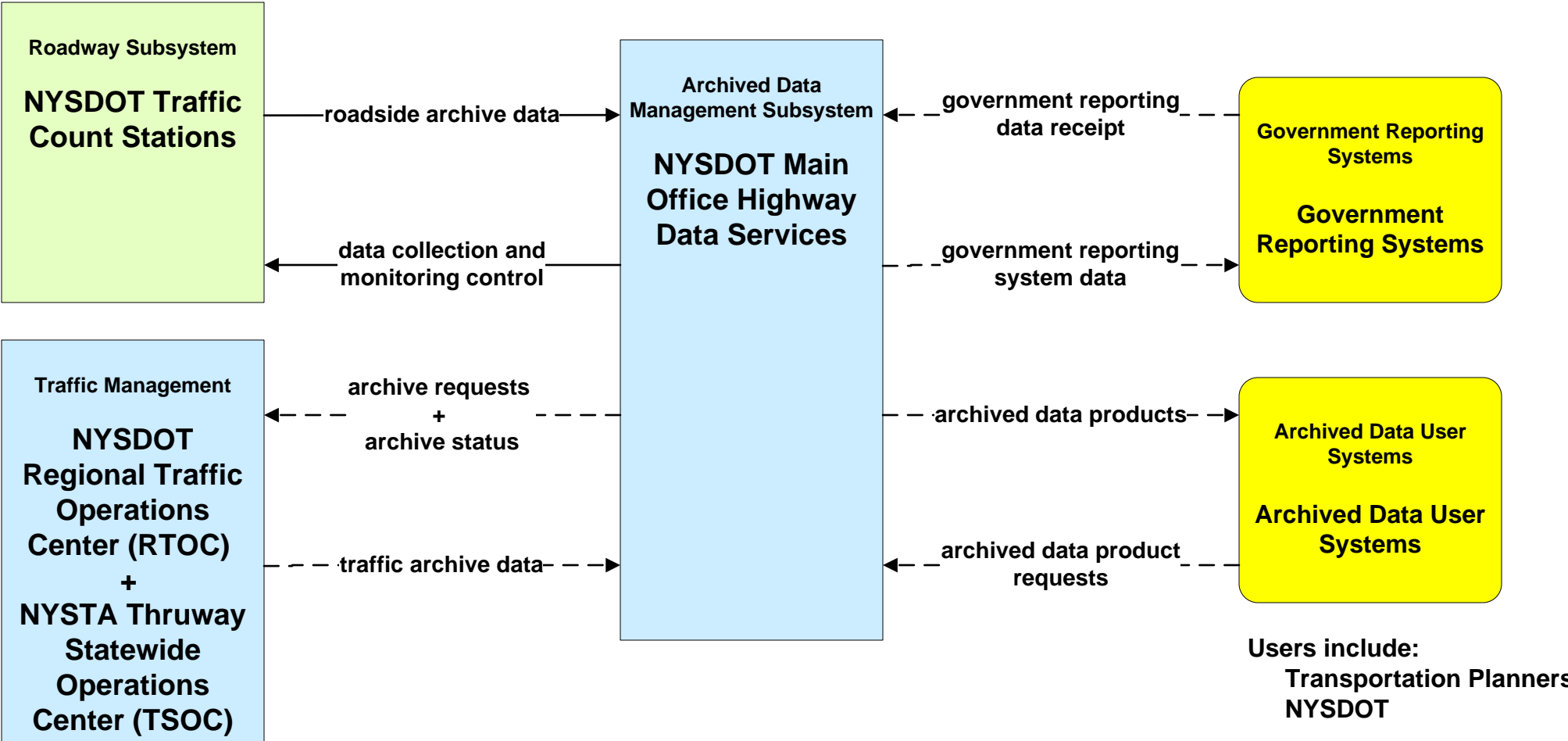
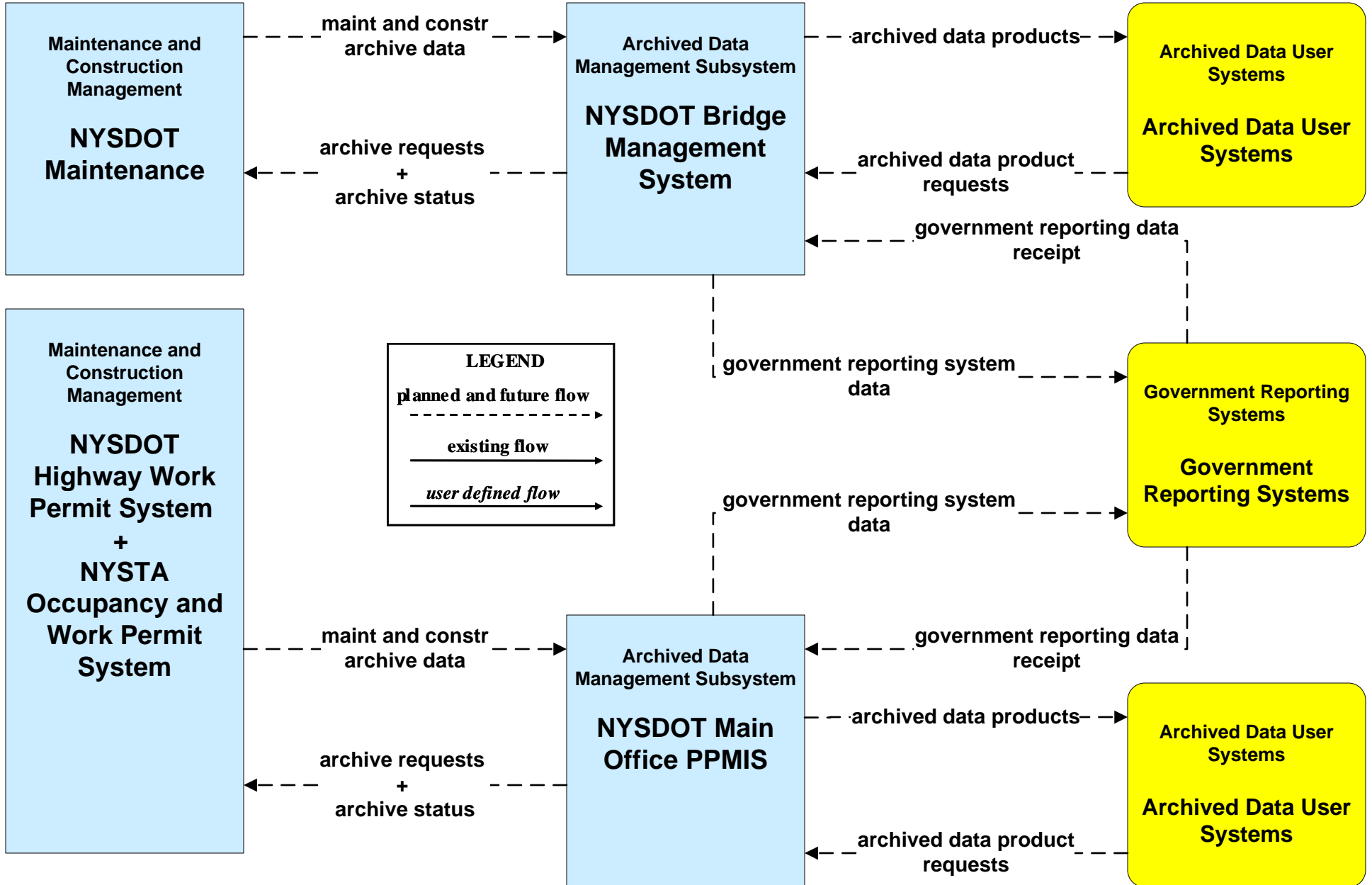

**AD1 - ITS Data Mart  
 NYSDOT / NYSTA Inventory Systems**

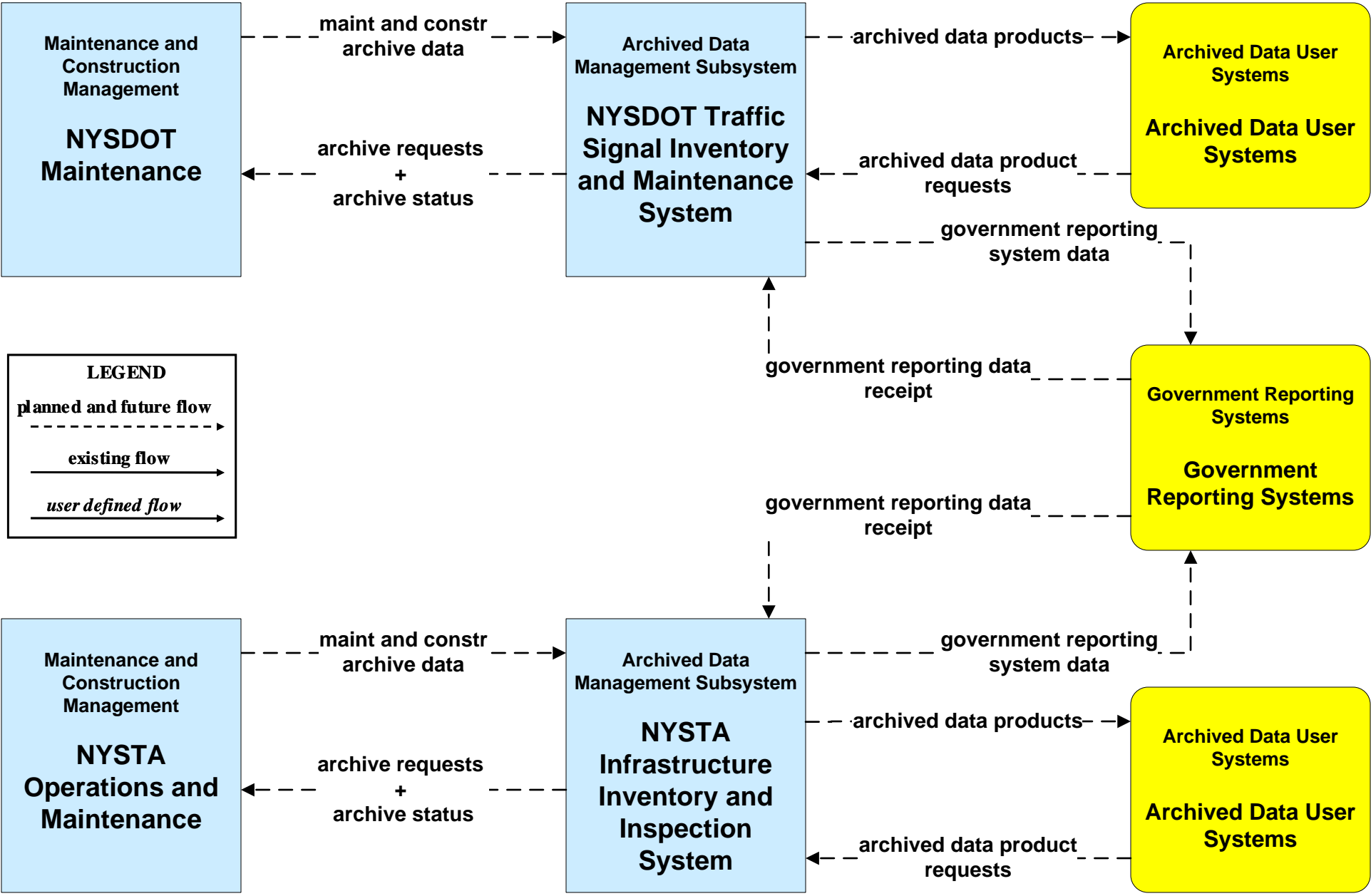

**LEGEND**

- planned and future flow* (dashed arrow)
- existing flow* (solid arrow)
- user defined flow* (solid arrow)

**AD1 - ITS Data Mart**  
**NYSTA Statewide Operations Center Archive Management System**

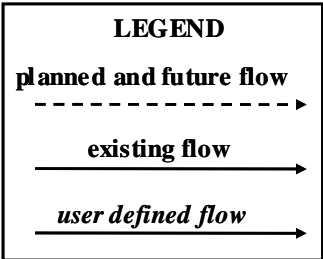
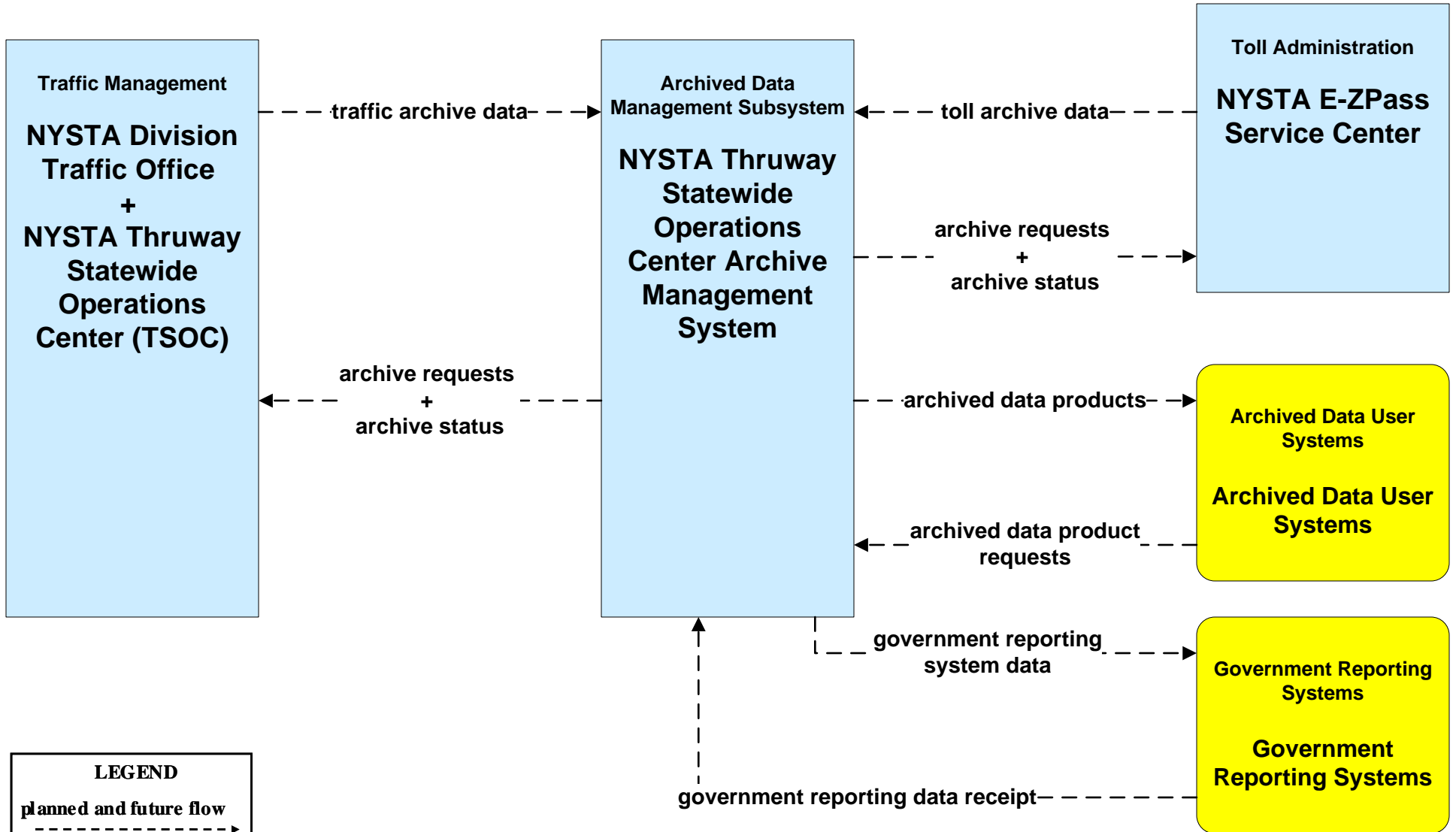

**Users include:**  
 Transportation Planners  
 NYSTA  
 Federal Highway Administration  
 Public Requests

**AD2 - ITS Data Warehouse  
 NYSDOT Infrastructure Restrictions Database**

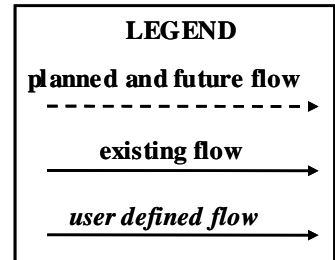
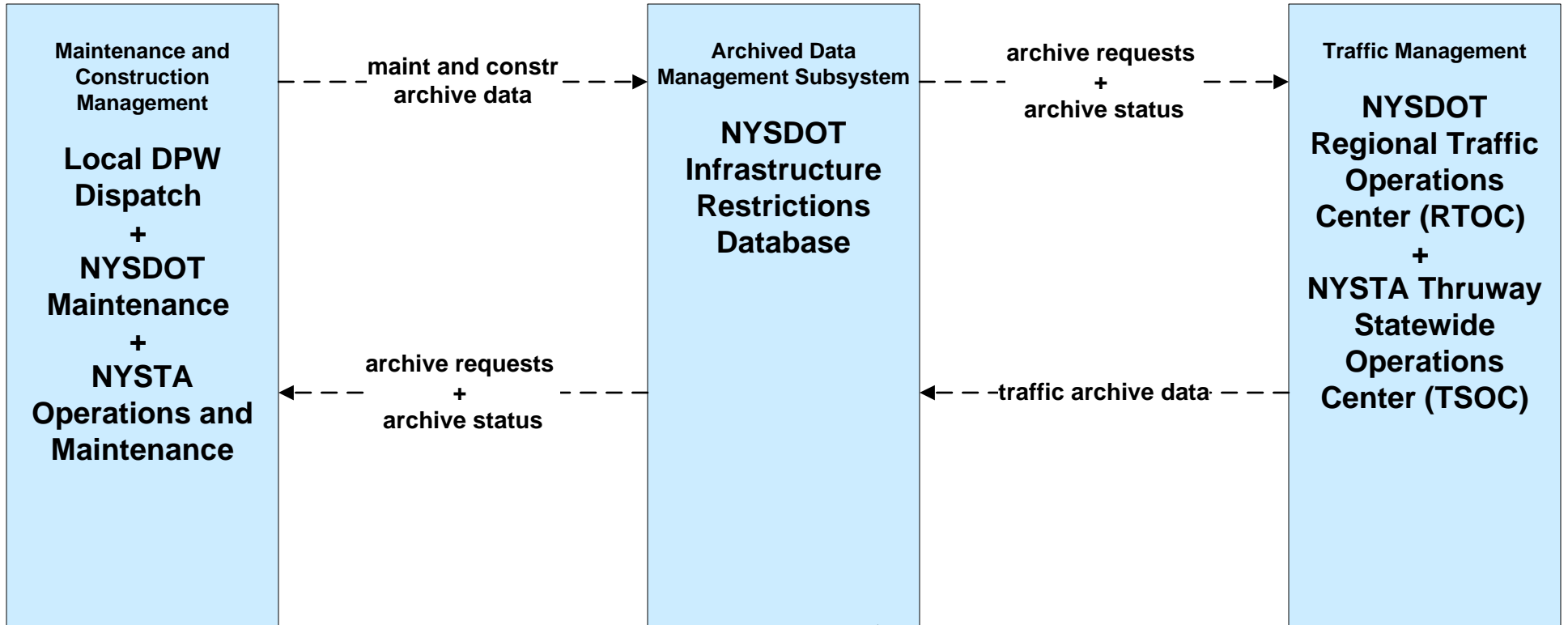

**Users include:**  
 Transit Agencies  
 NYSDOT  
 Area Fire/Police  
 Local EMS  
 Public Requests  
 CVO Permit Agencies

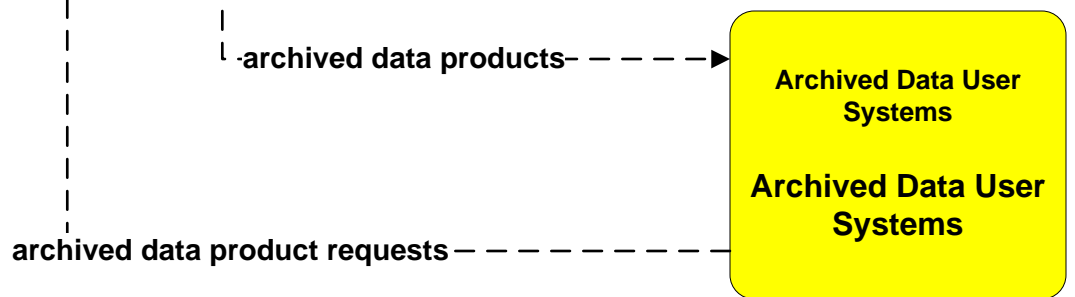

**AD3 - ITS Virtual Data Warehouse  
Archive Data Sharing Network**

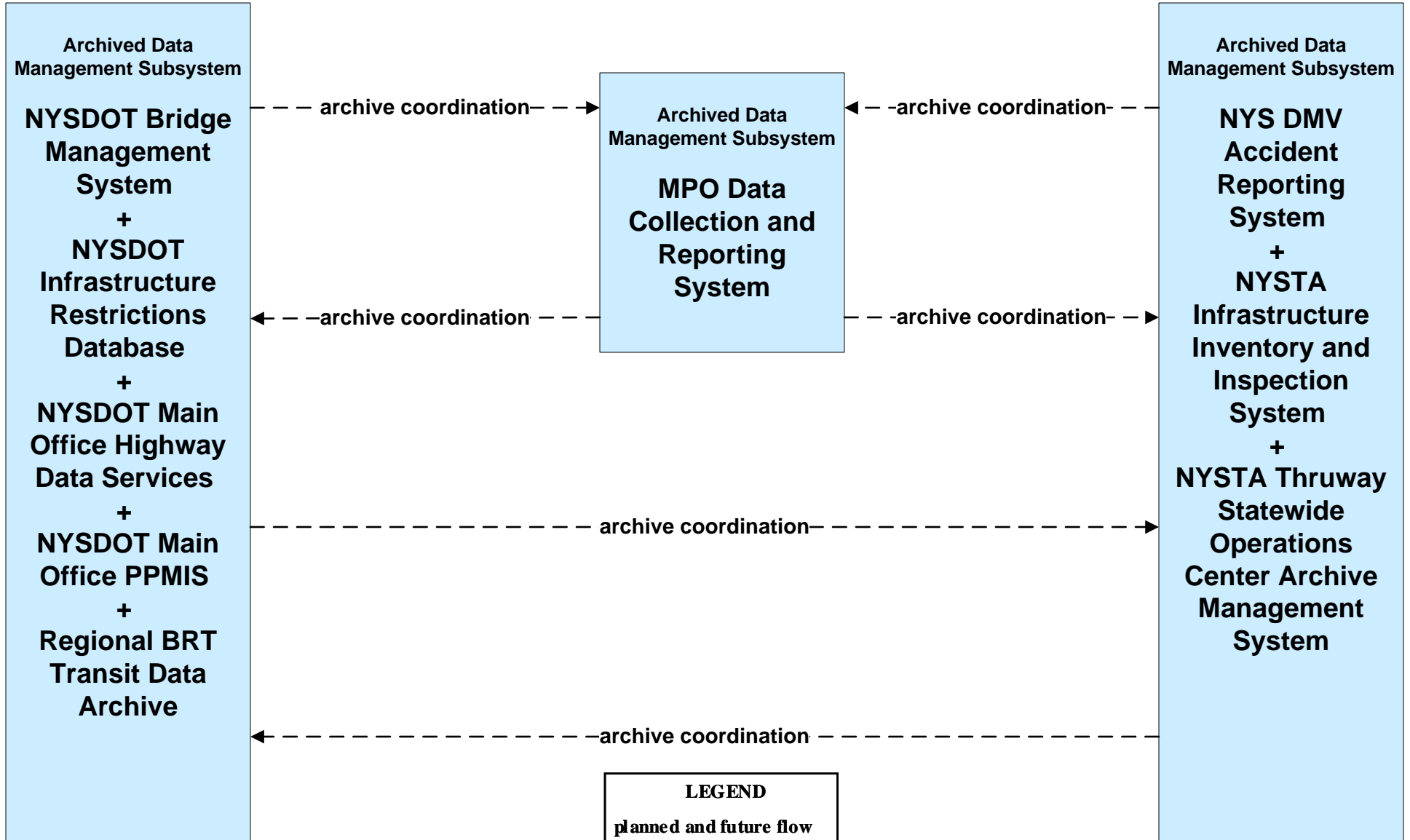

**ATIS01 - Broadcast Traveler Information  
NYSDOT 511.ORG (3 of 3)**

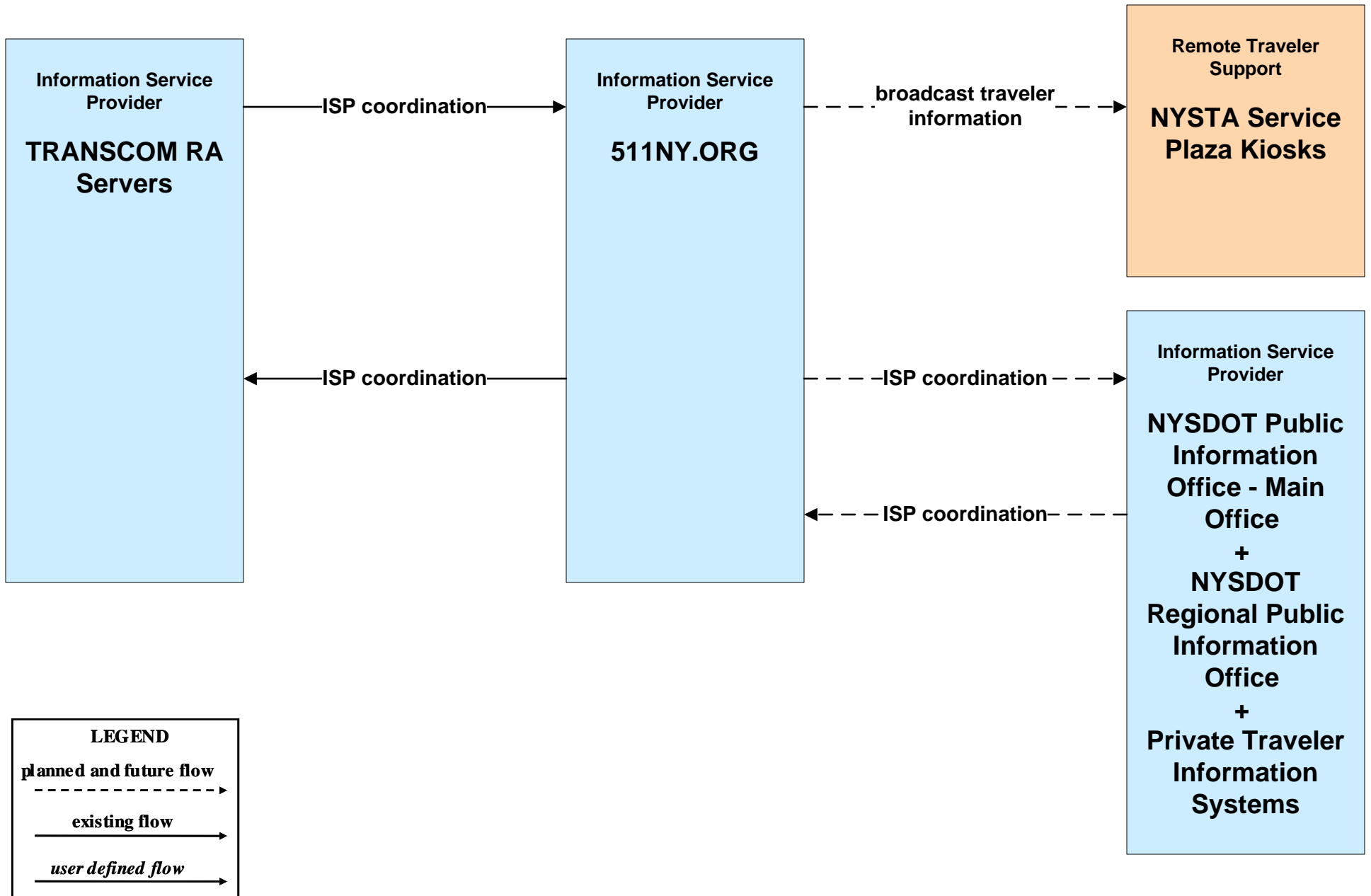

# ATMS01 - Network Surveillance NYSTA

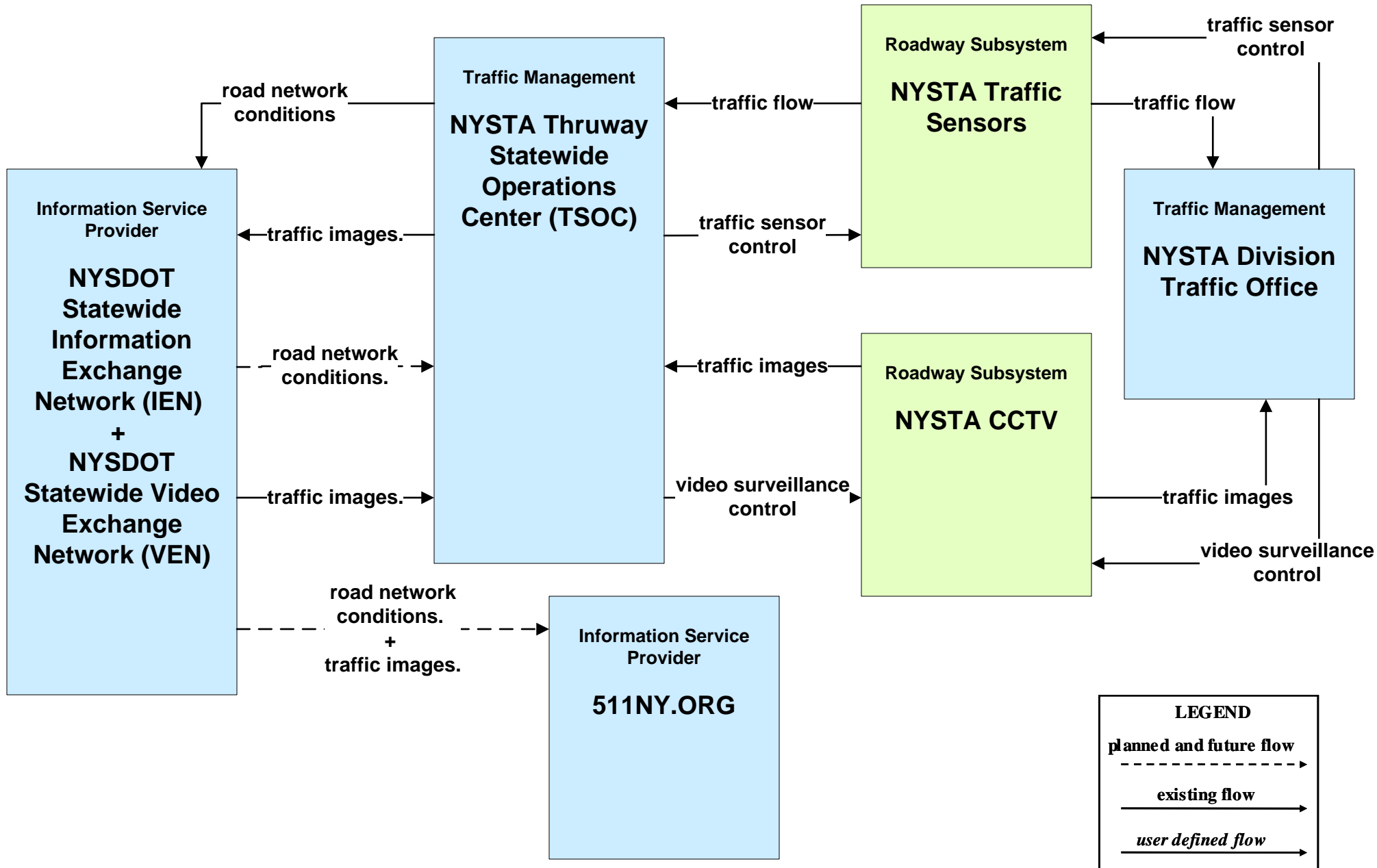



# ATMS04 - Freeway Control NYSTA

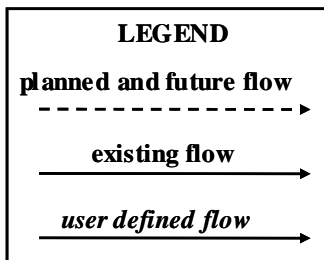
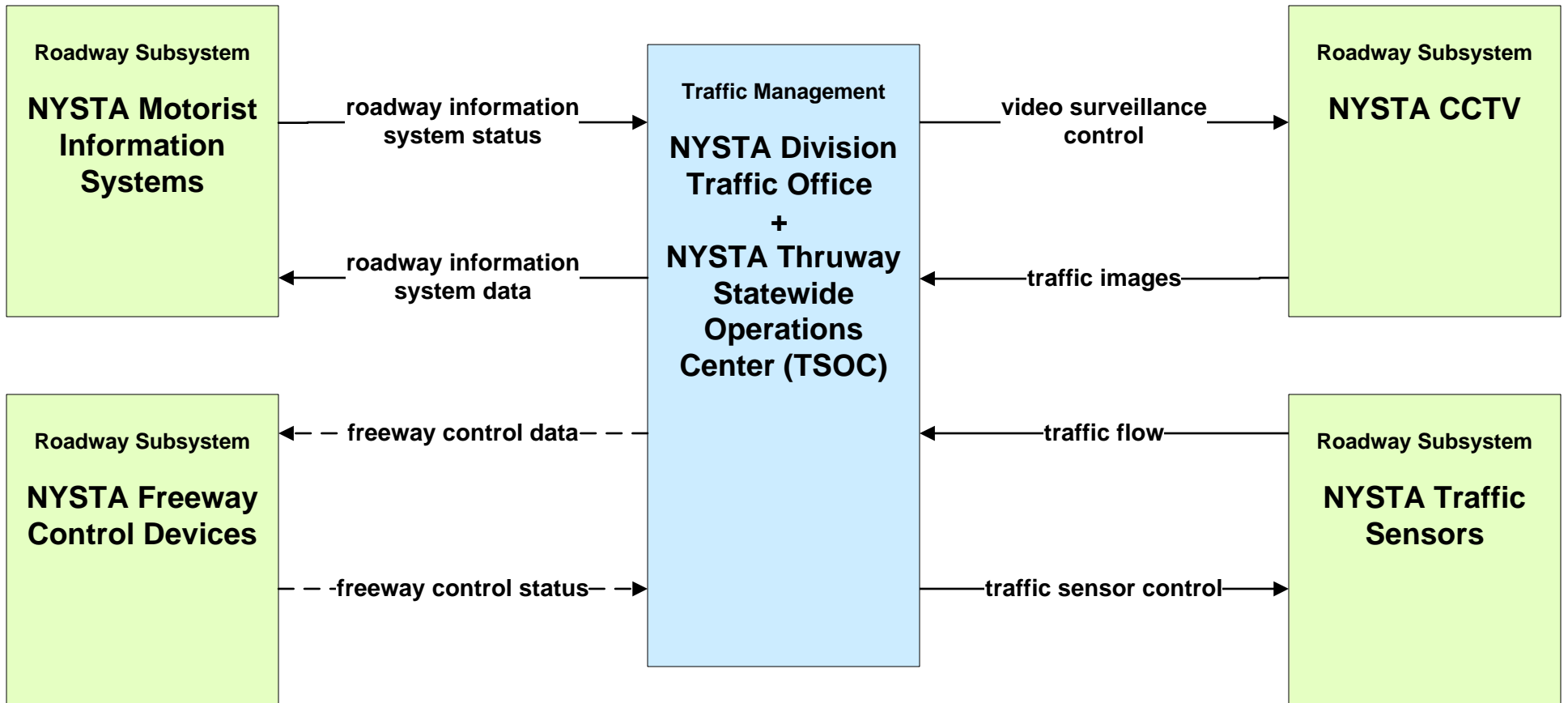

**ATMS06 - Traffic Information Dissemination  
NYSDOT (3 of 3)**

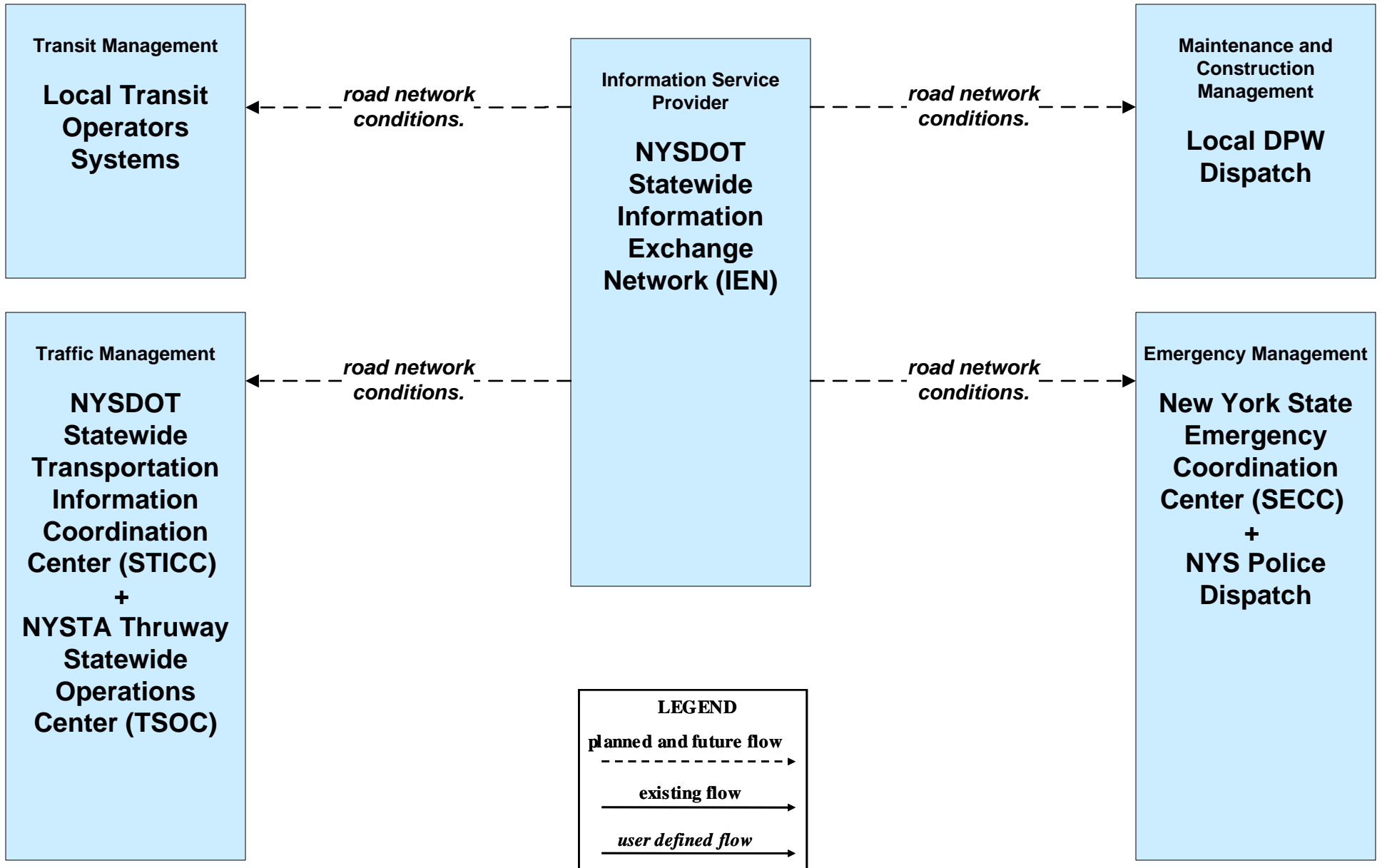

# ATMS06 - Traffic Information Dissemination NYSTA

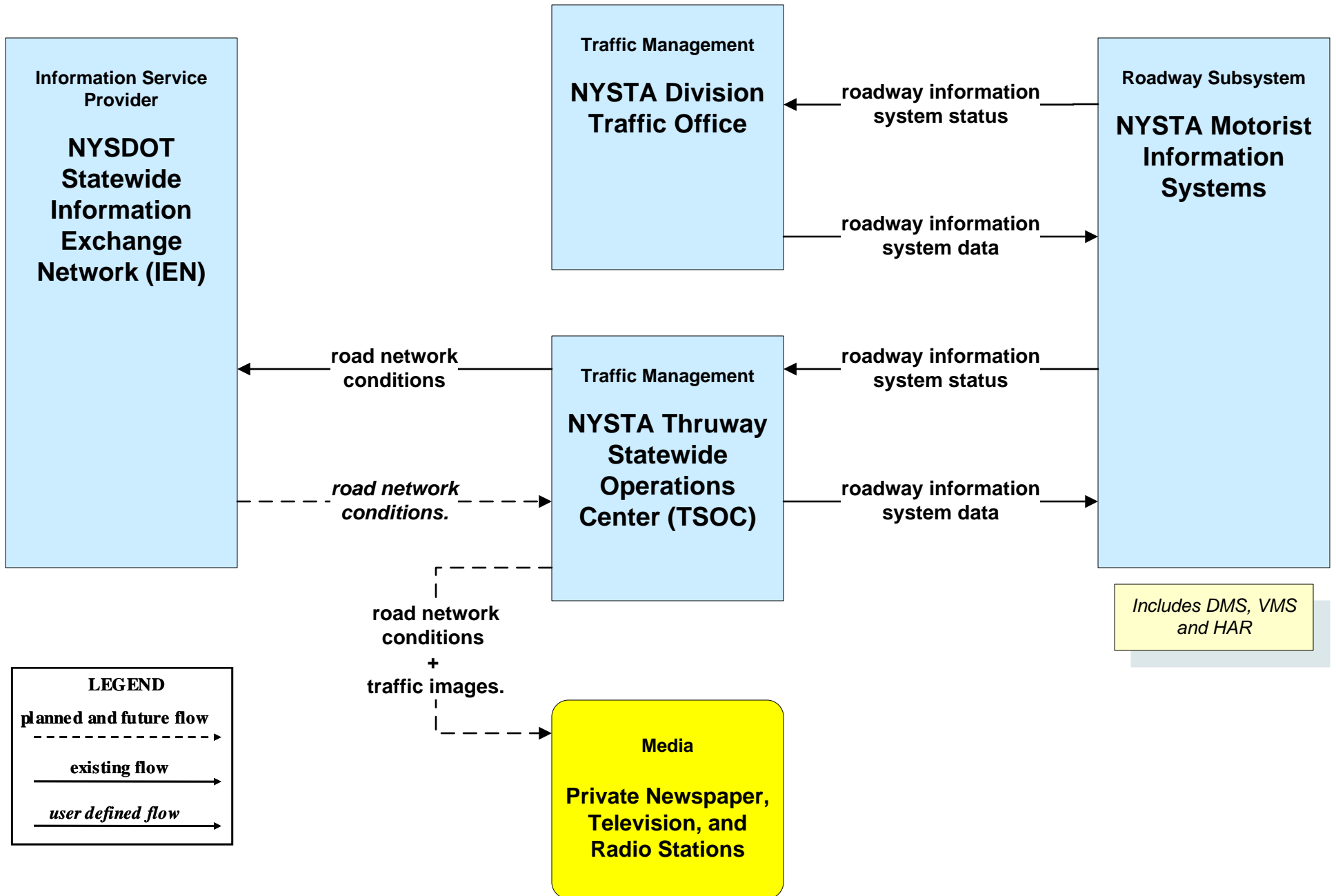

**ATMS07 - Regional Traffic Management  
 NYSDOT Statewide Information Exchange Network (IEN)**

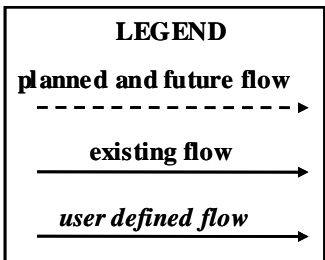
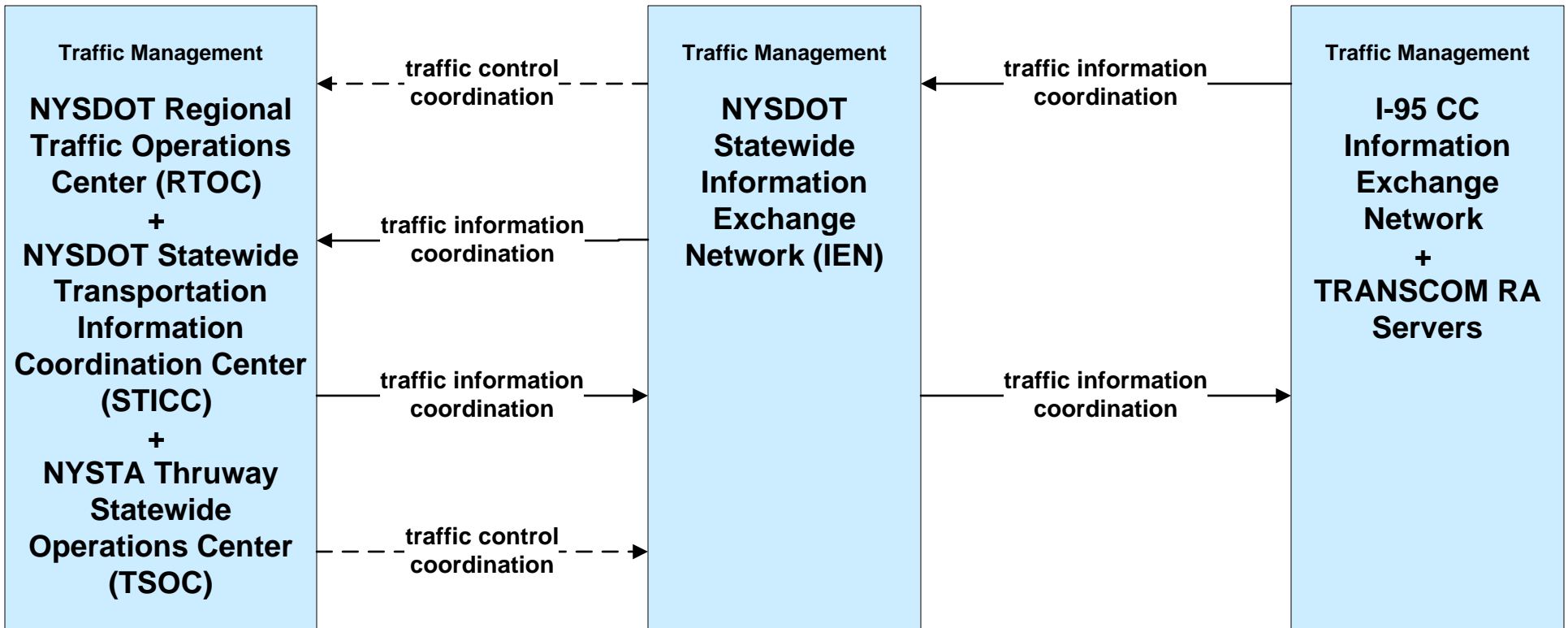

*Note: 511NY.ORG is a part of the IEN.*

**ATMS07 - Regional Traffic Management  
NYSDOT Statewide Video Exchange Network (VEN)**

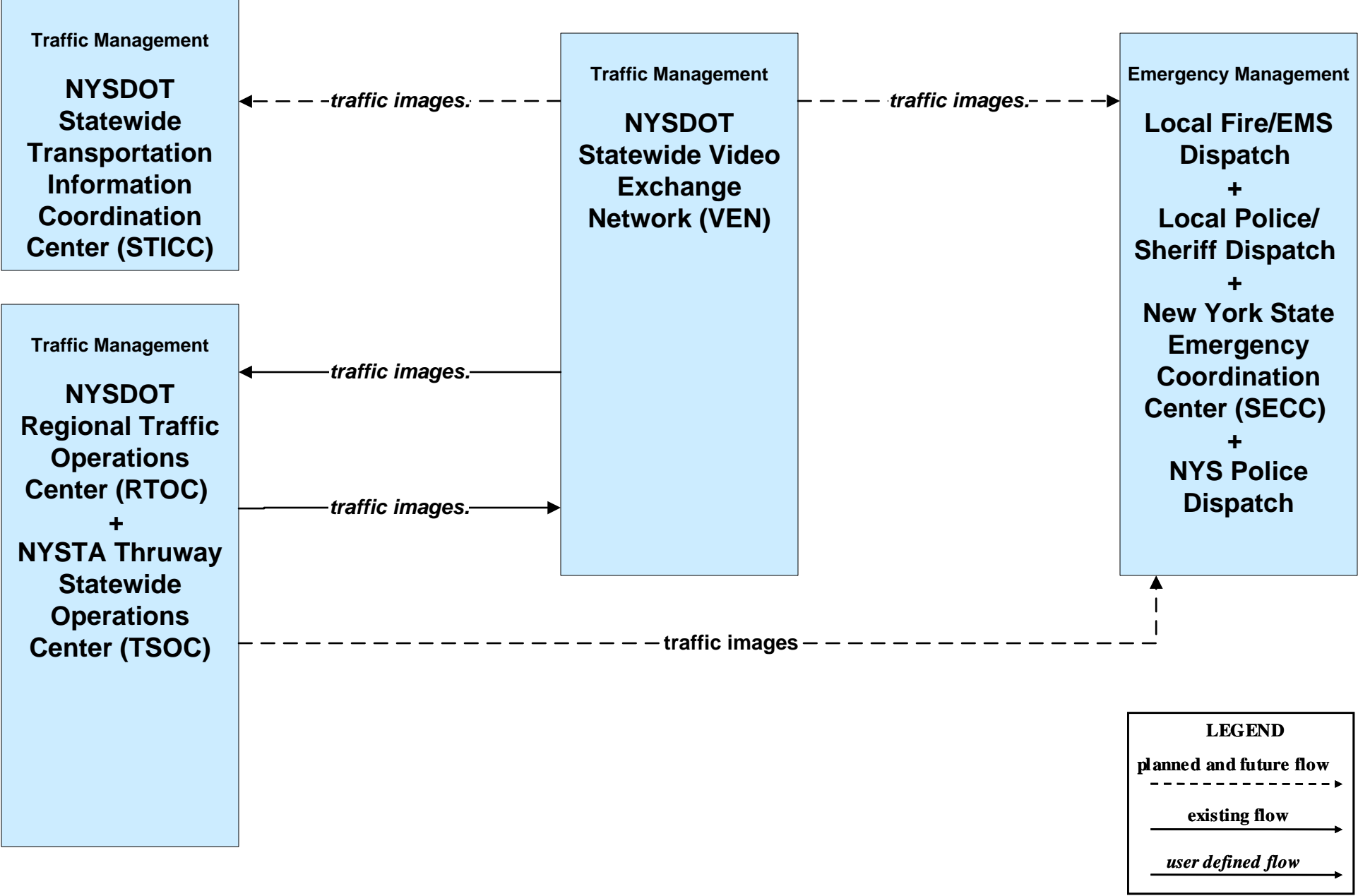

**ATMS07 - Regional Traffic Management  
NYSTA**

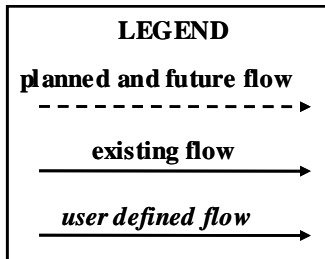
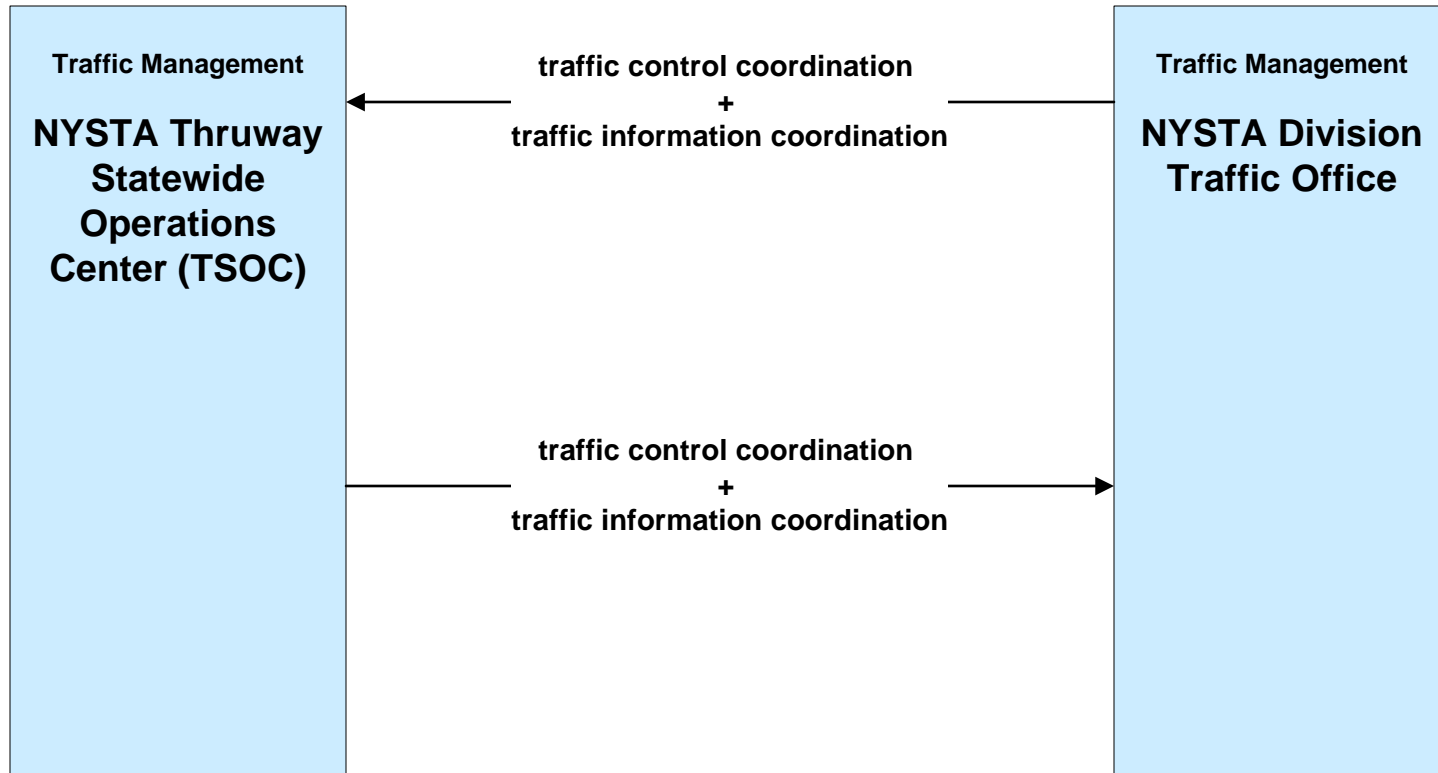

**ATMS08 - Incident Management  
 NYSDOT IEN (TM to EM)**

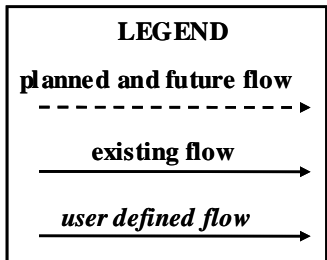
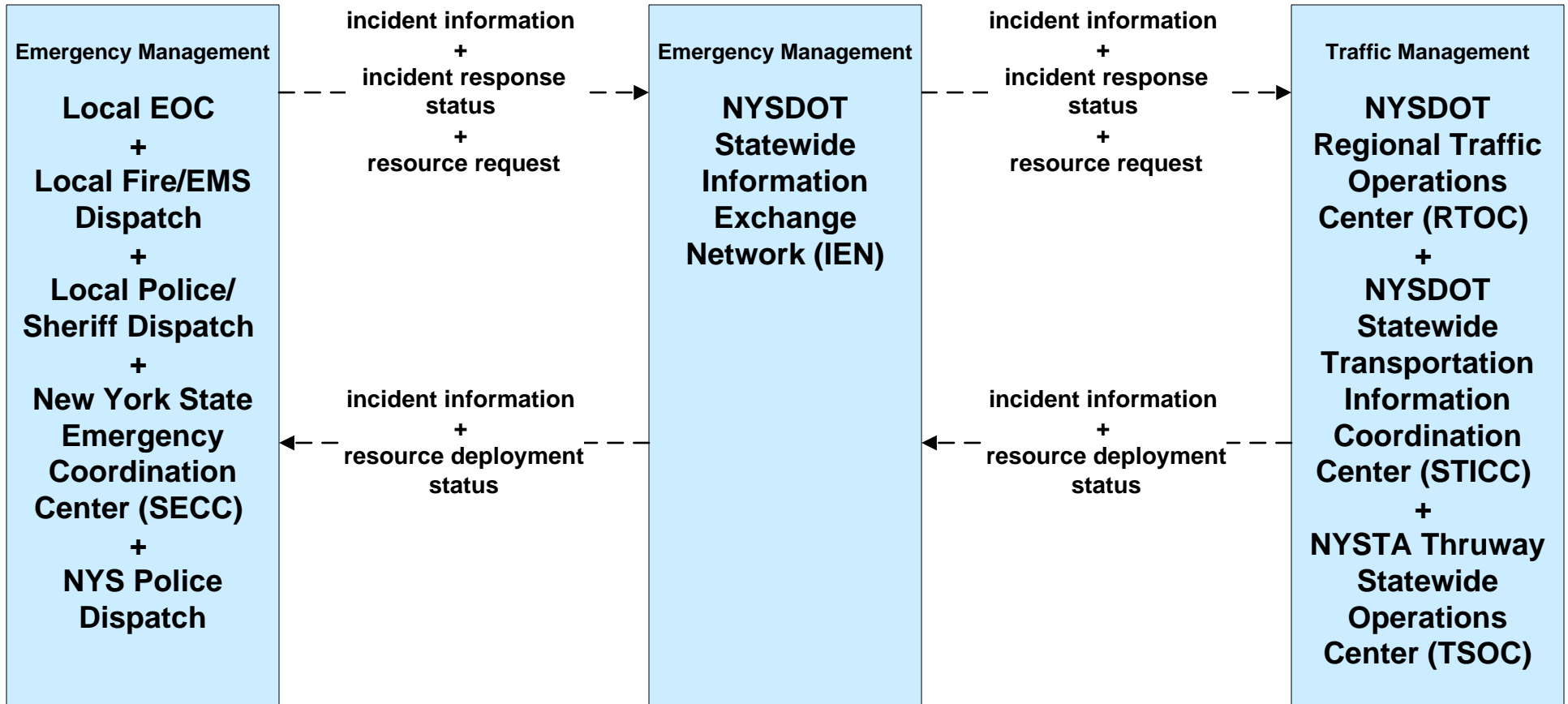

# ATMS08 - Incident Management NYSTA (TM to EM)

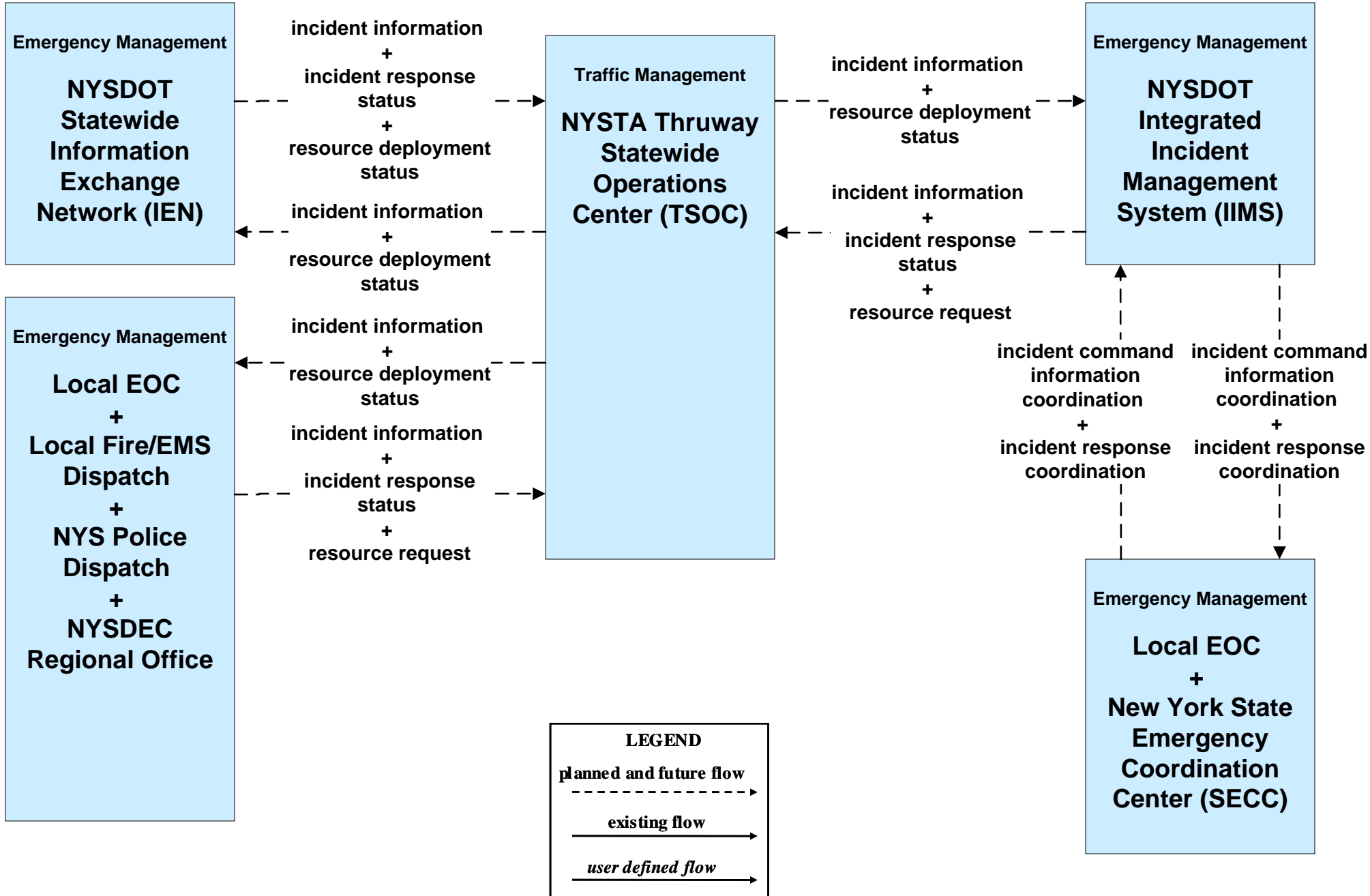



**ATMS08 - Incident Management  
NYSTA (TM to MCM)**

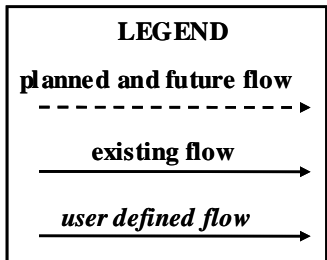
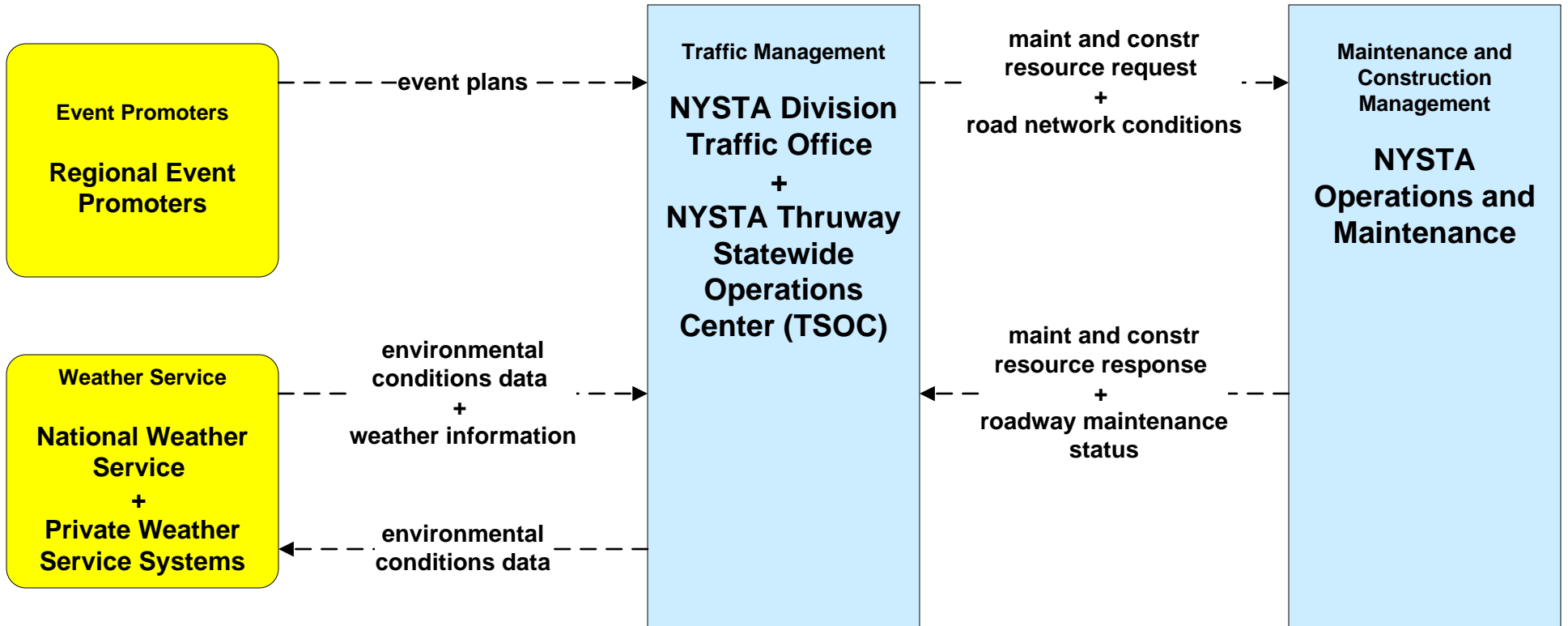

**ATMS08 - Incident Management**  
**NYSDOT STICC / NYSDOT Regional TOCs (EM to MCM)**

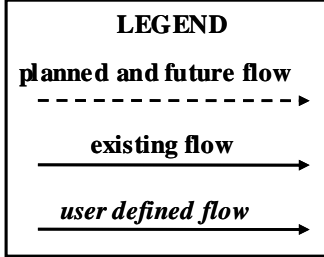
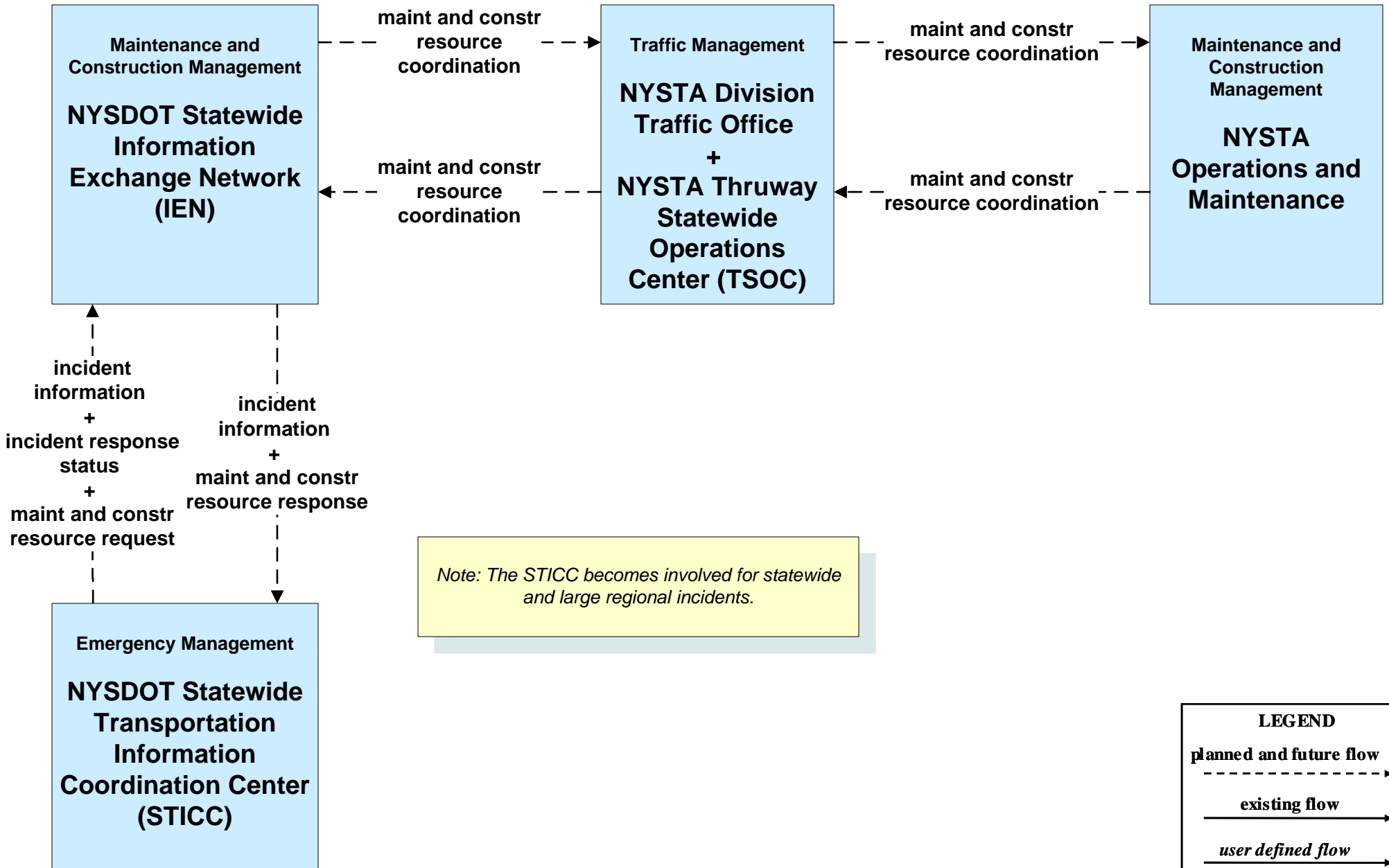

**ATMS08 - Incident Management  
NYSTA (EM to MCM)**

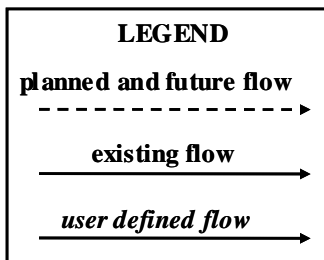
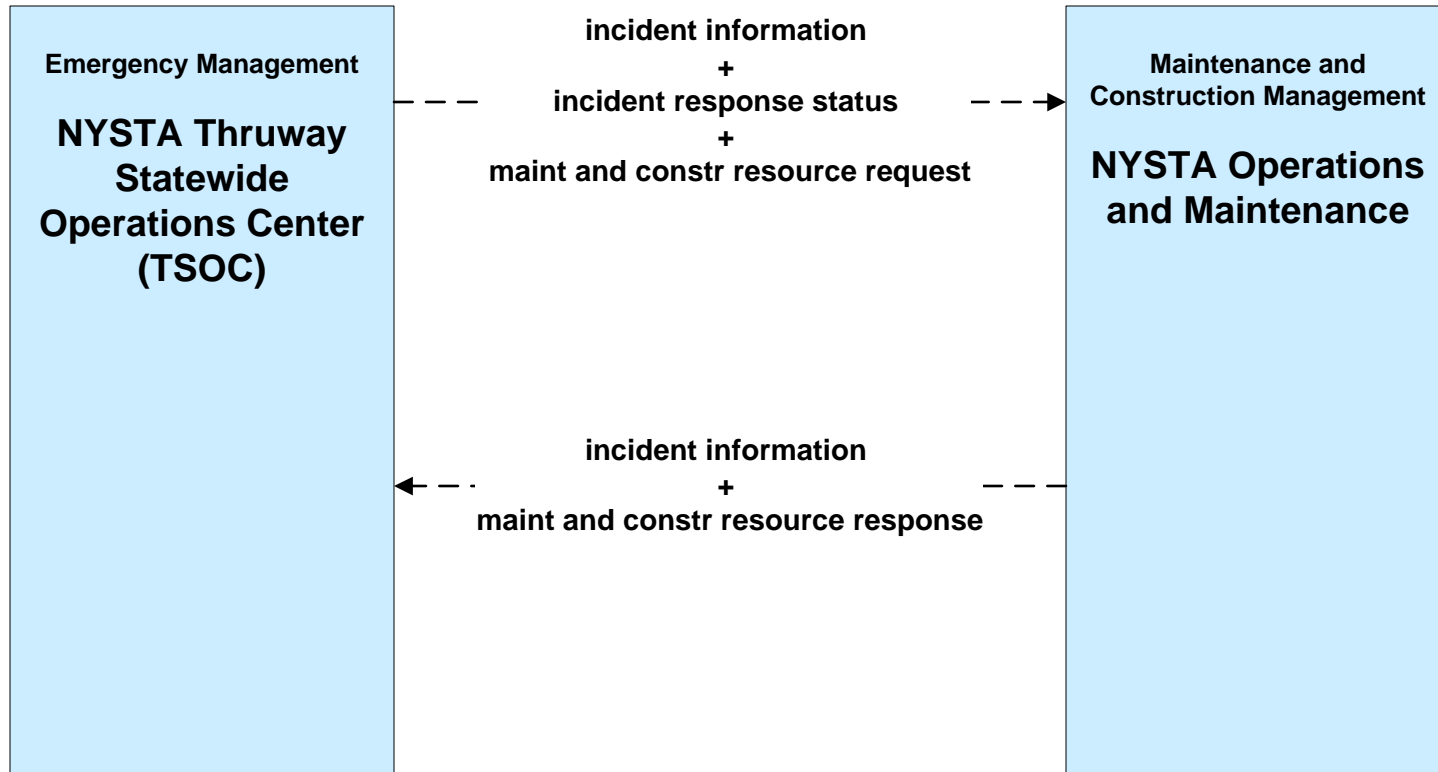

**ATMS08 - Incident Management  
 NYSDOT Regional TOCs, NYSTA and IIMS**

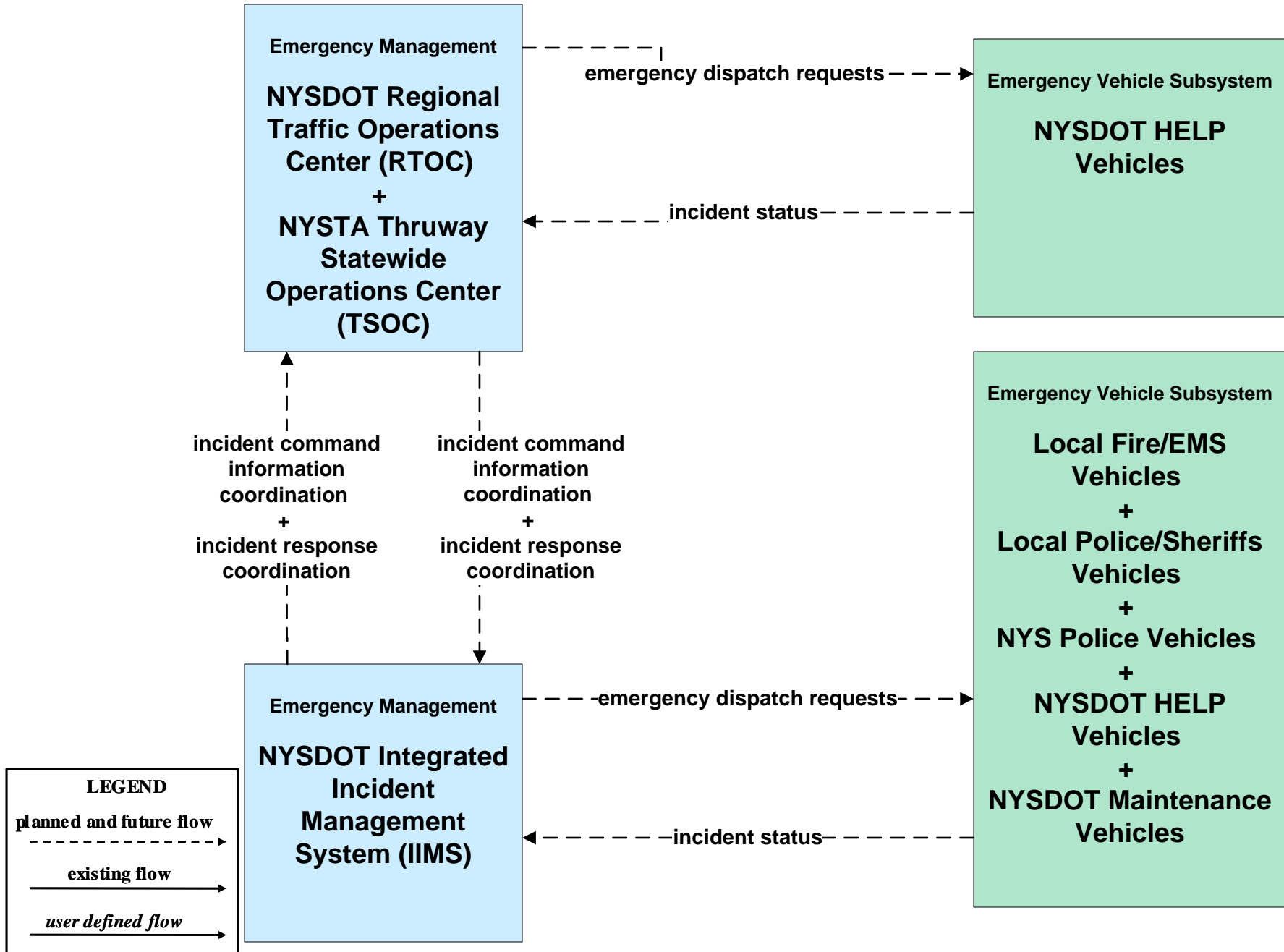

# ATMS10 - Electronic Toll Collection NYSTA Electronic Tolling

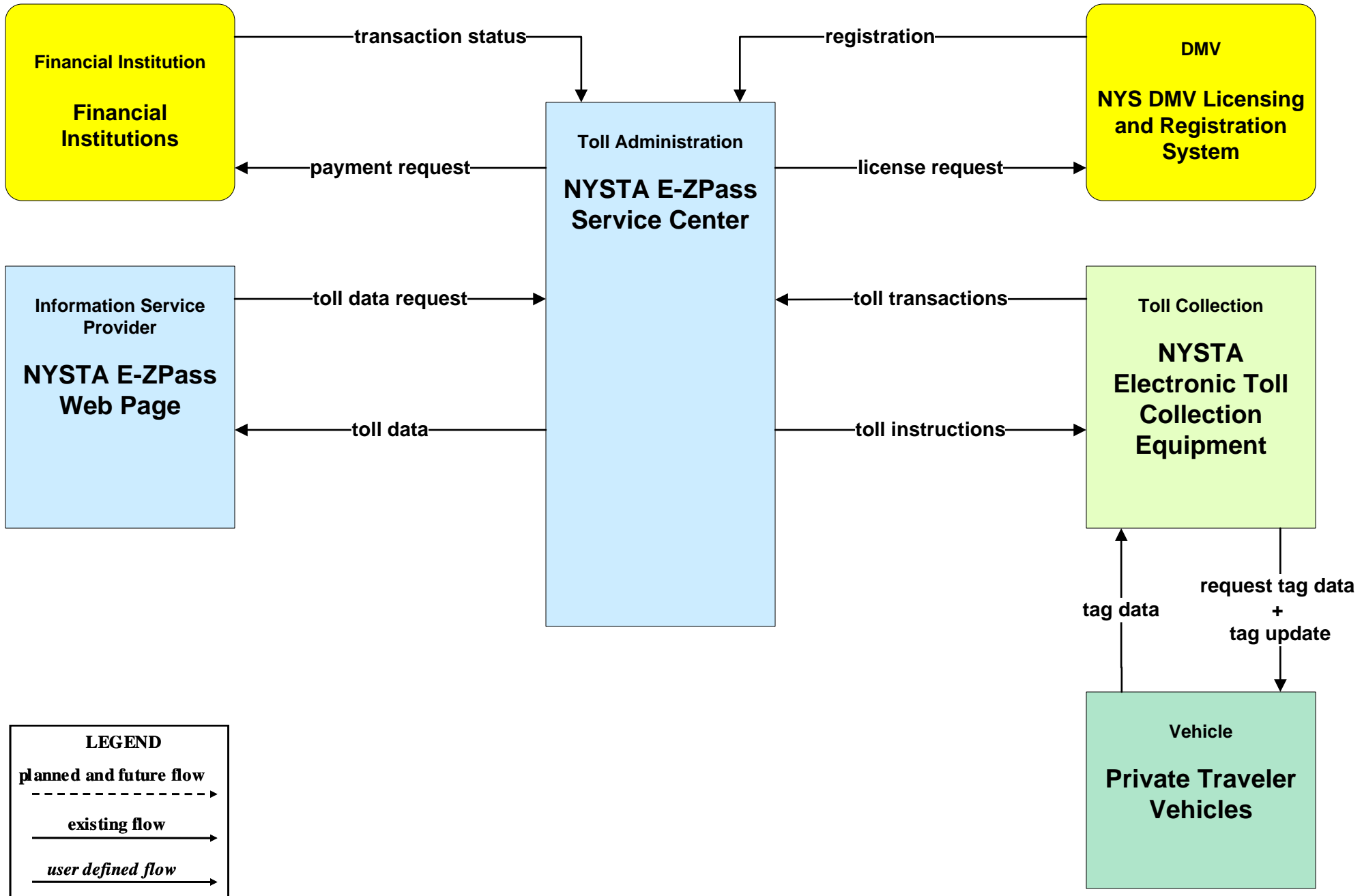

**ATMS18 - Reversible Lane Management  
NYSTA**

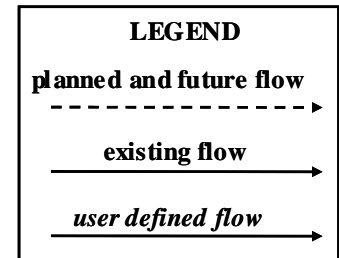
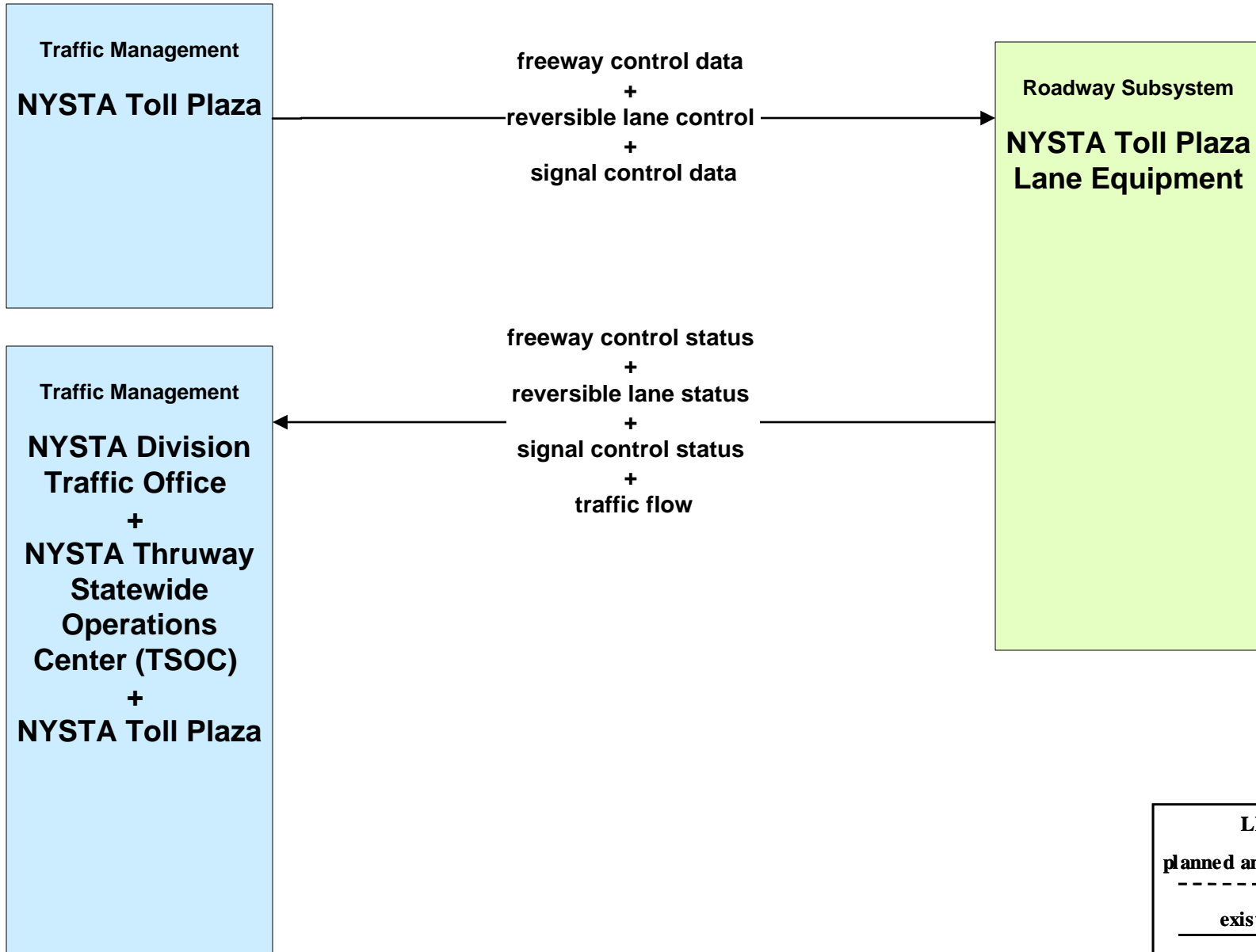

**CVO03 - Electronic Clearance**  
**New York State Commercial Vehicle Safety Roadside Inspection Operations (2 of 2)**

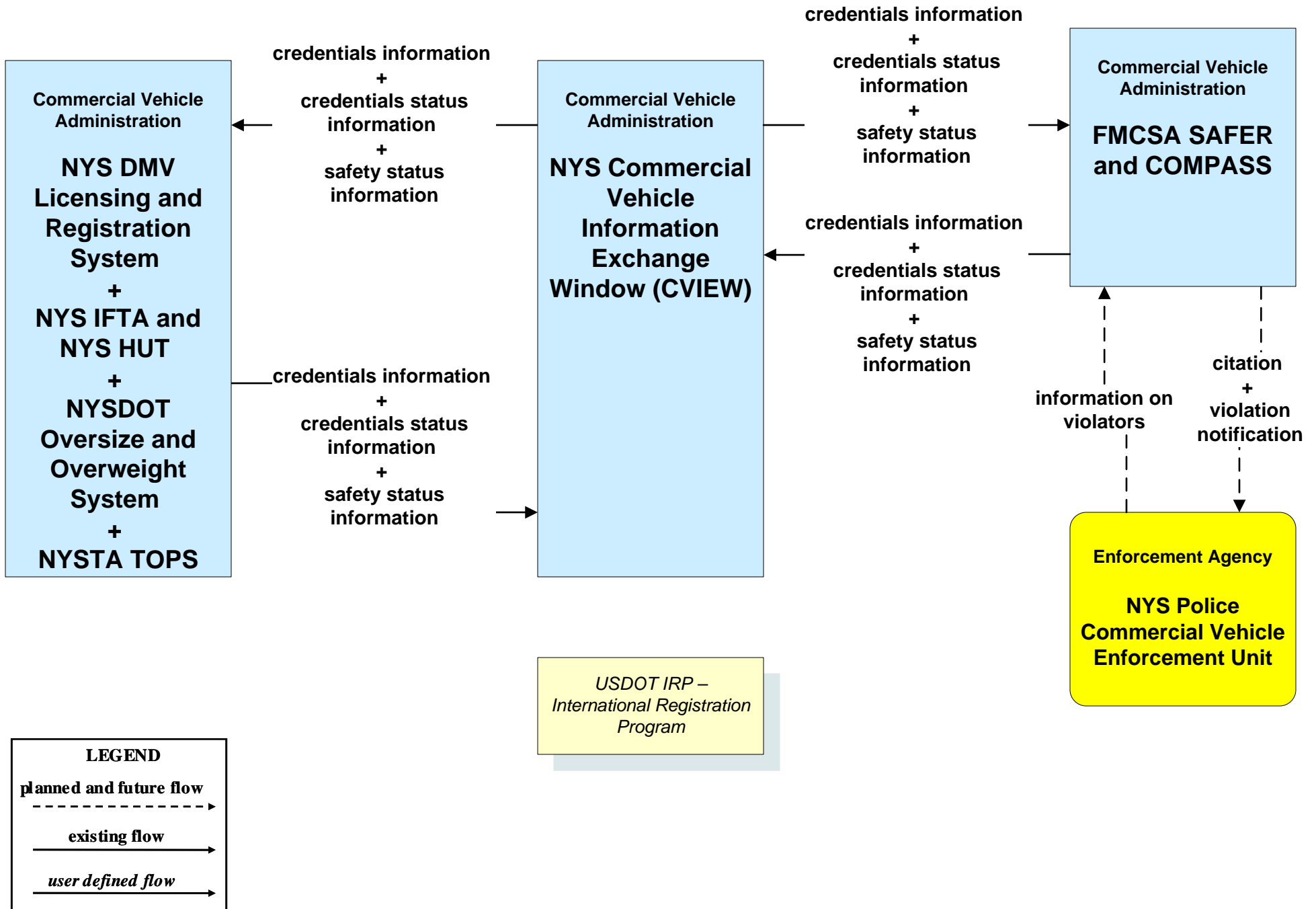

# CVO03 - Electronic Clearance NYSTA

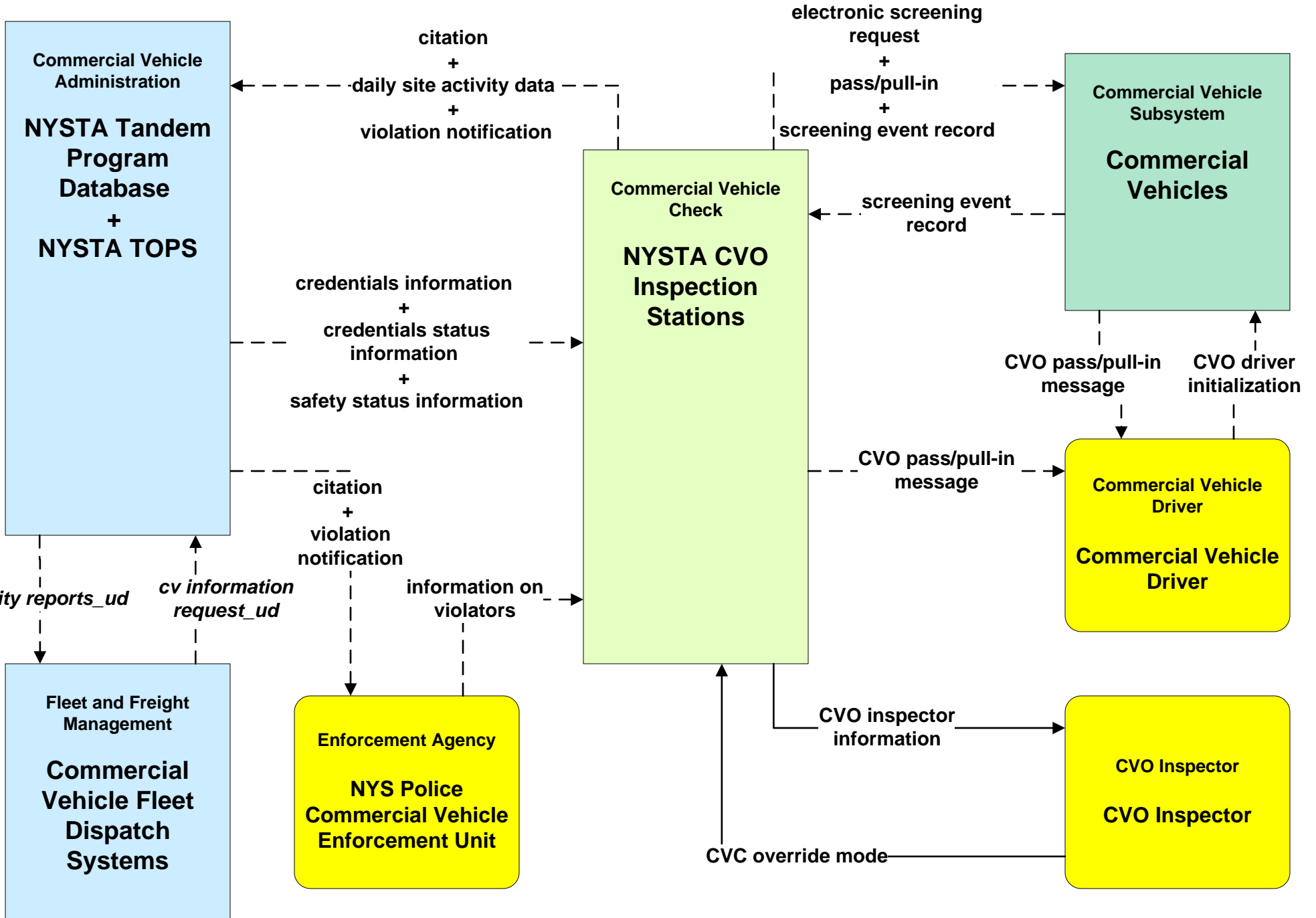



**CVO04 - CV Administrative Process  
NYSDOT OSCAR**

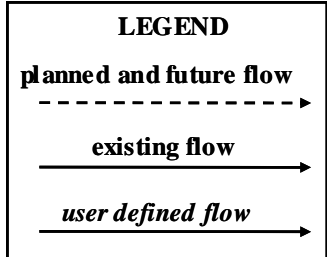
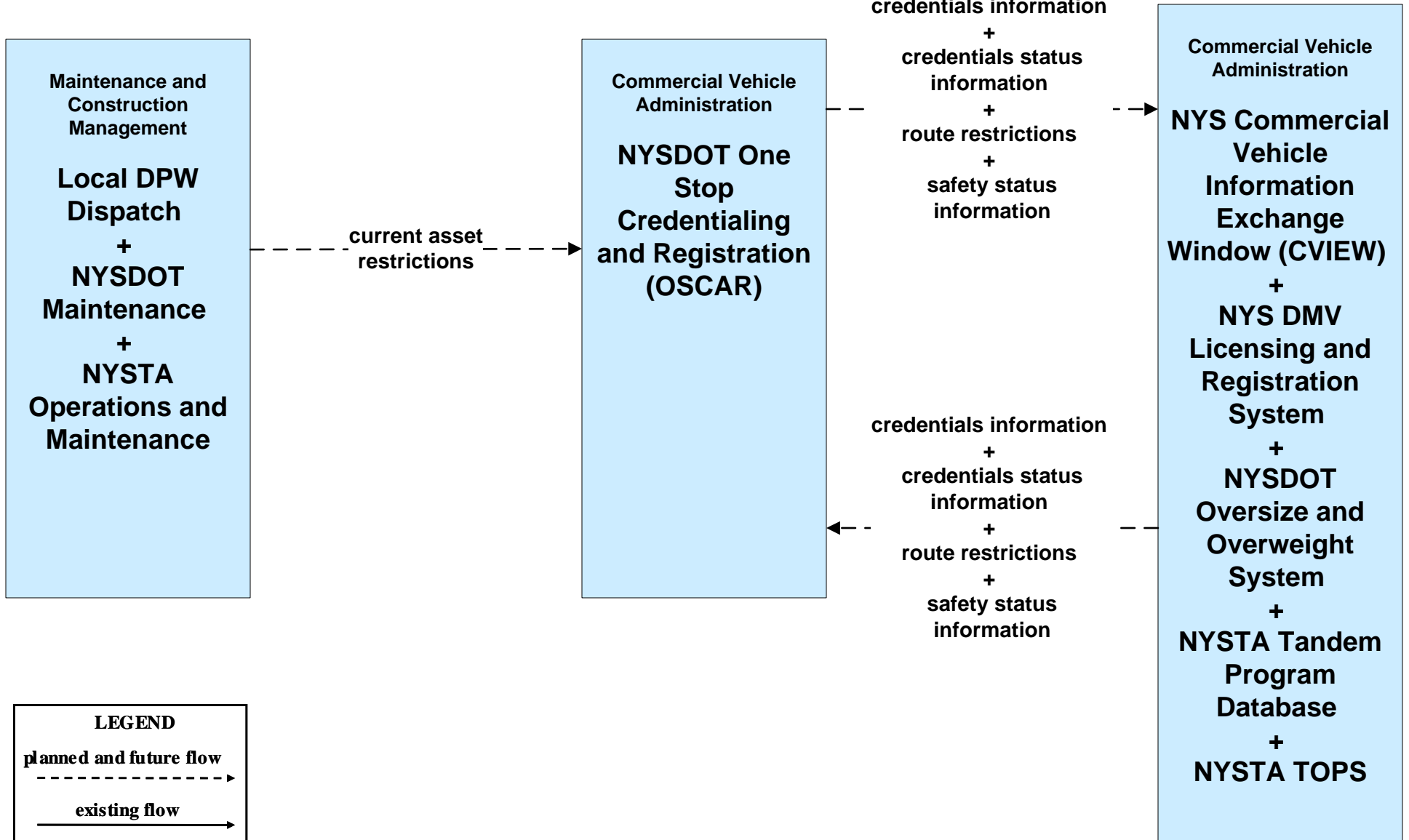

**CVO07 - Roadside CVO Safety  
New York State (2 of 2)**

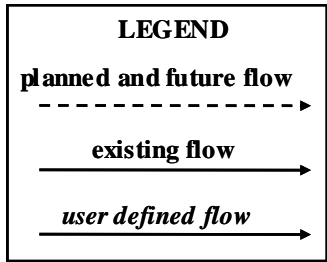
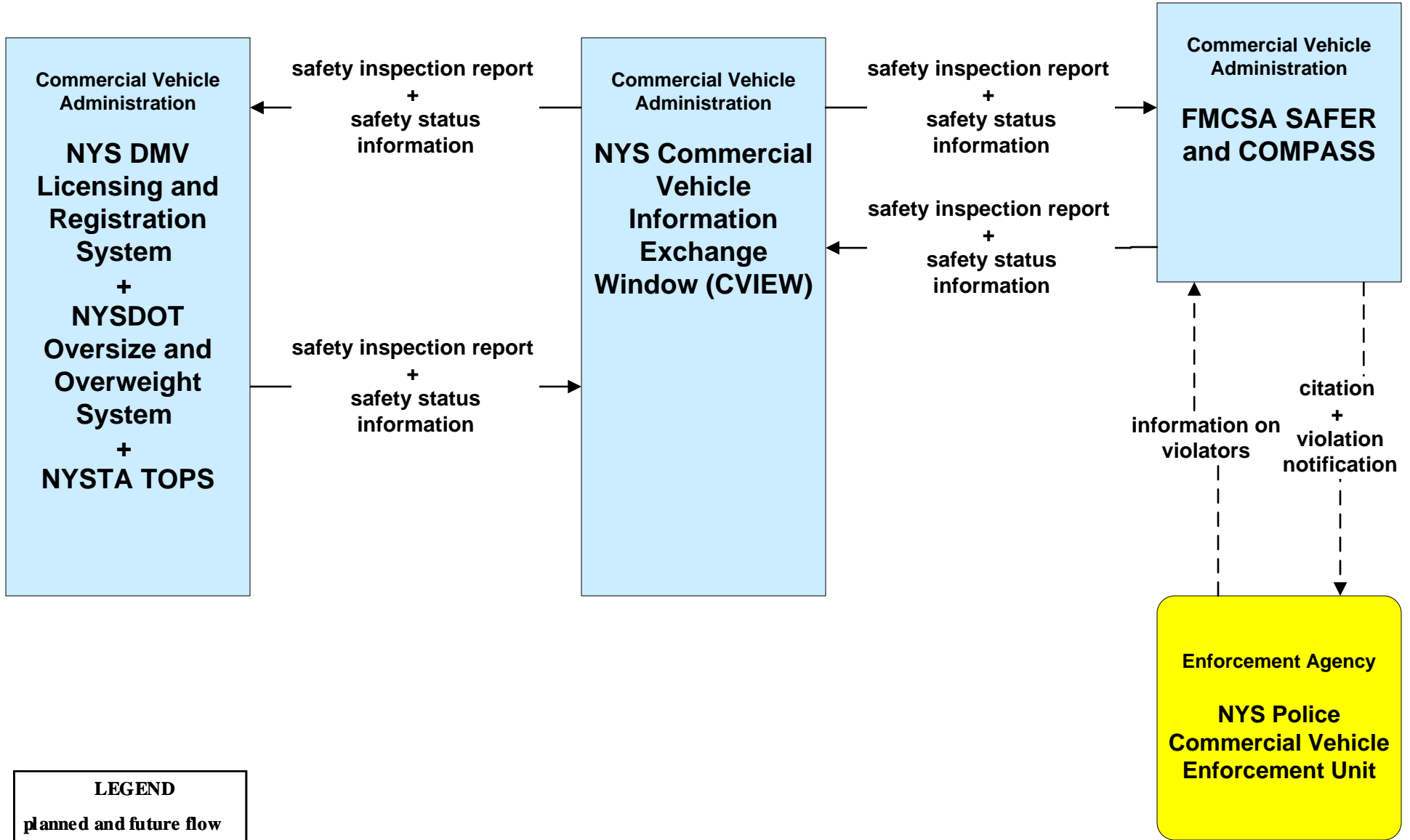

# CVO07 - Roadside CVO Safety NYSTA

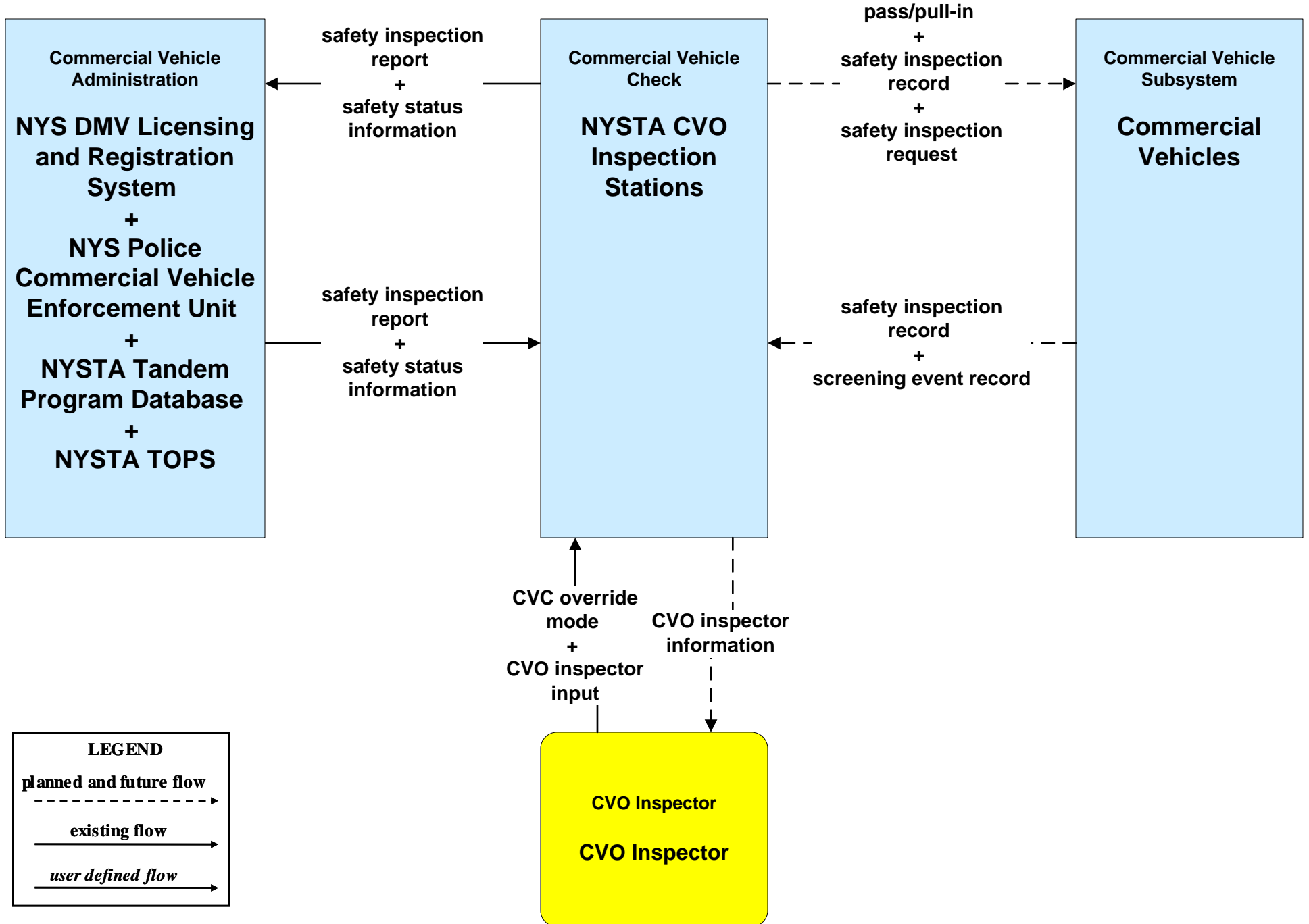

**EM01 - Emergency Call-Taking and Dispatch  
 NYSDOT Statewide Transportation Information Control Center (STICC) and  
 Statewide Information Exchange Network (IEN)**

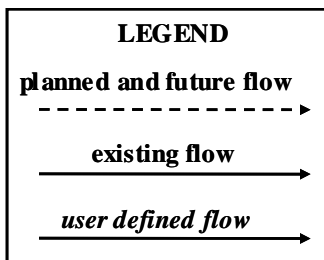
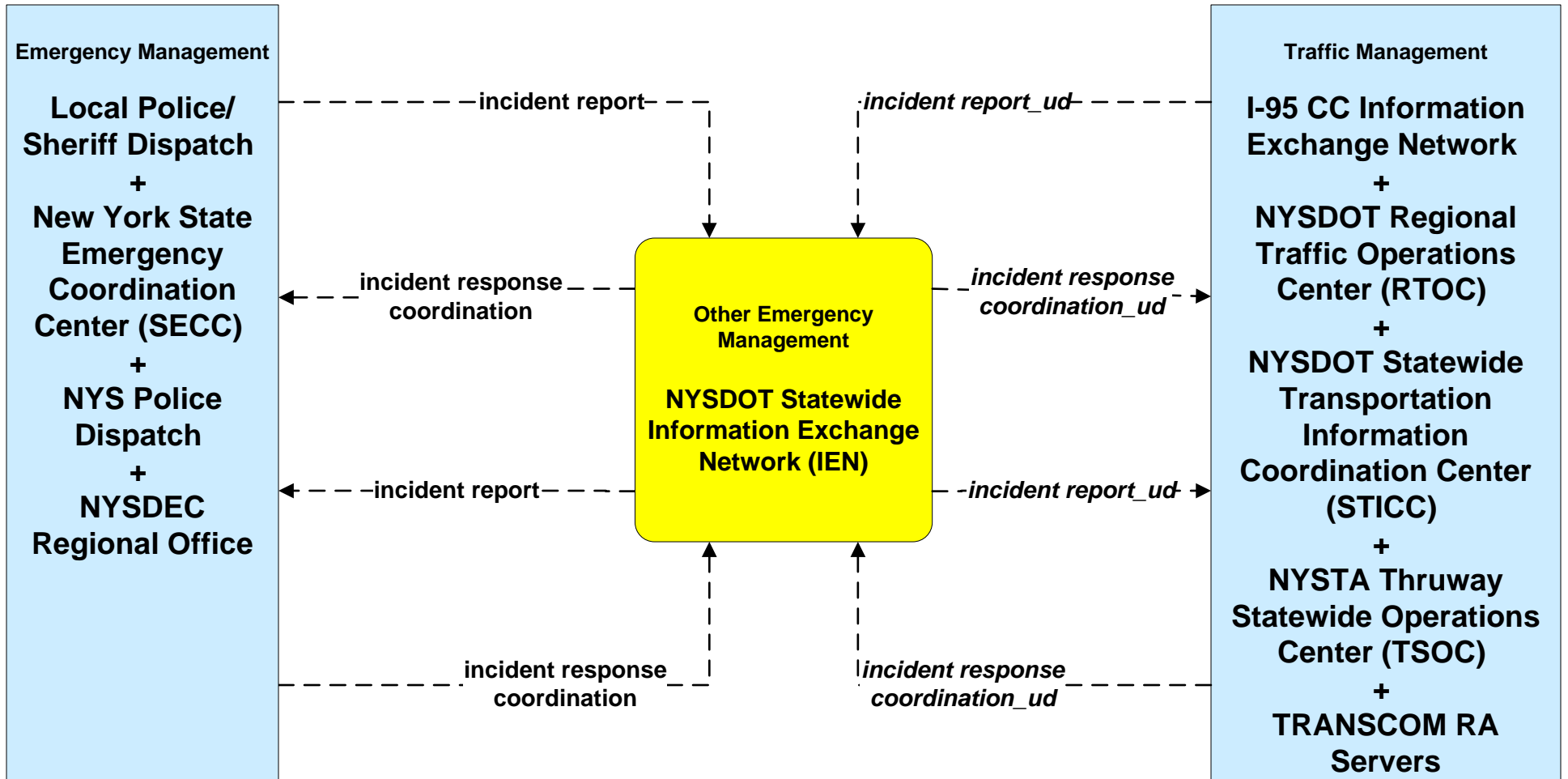

# EM04 - Roadway Service Patrols NYSDOT HELP Vehicles

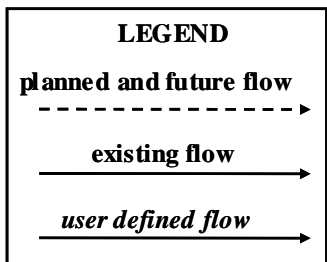
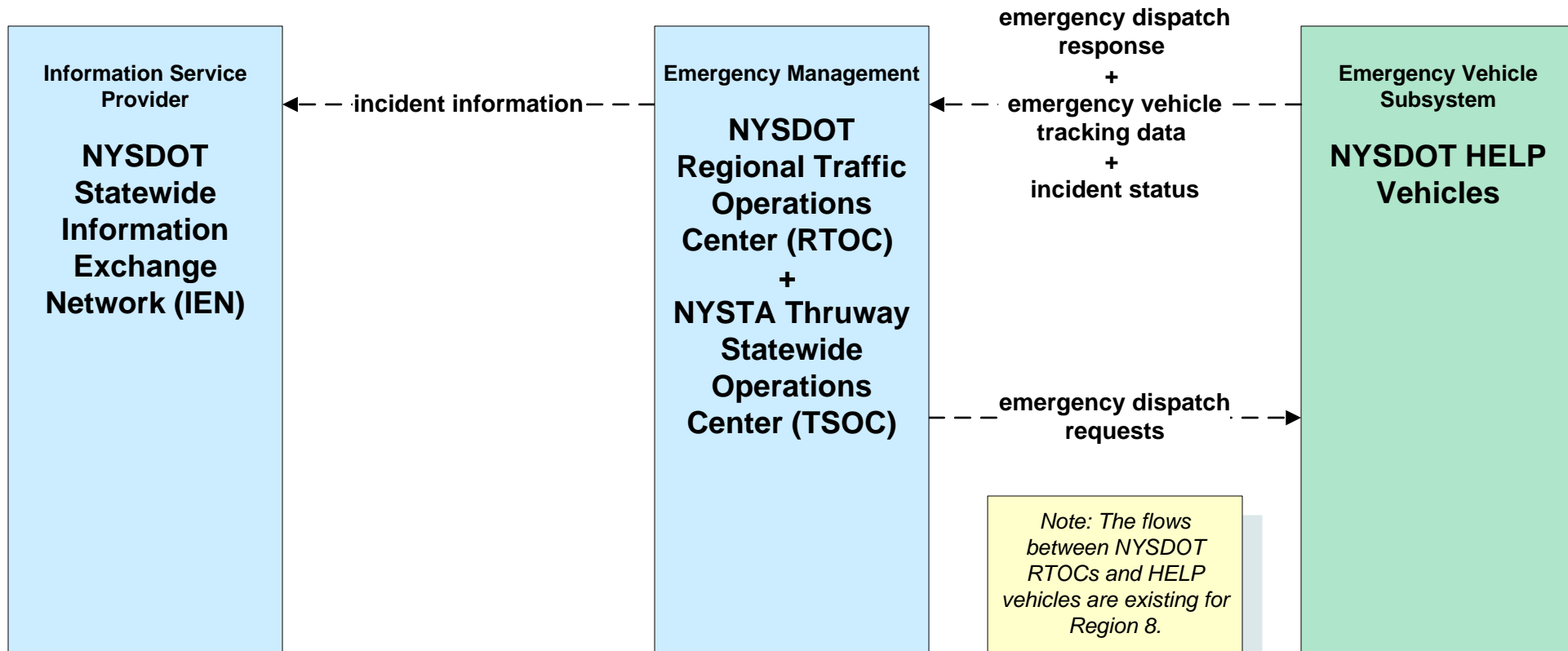

**EM04 - Roadway Service Patrols  
NYSDOT IIMS Vehicles**

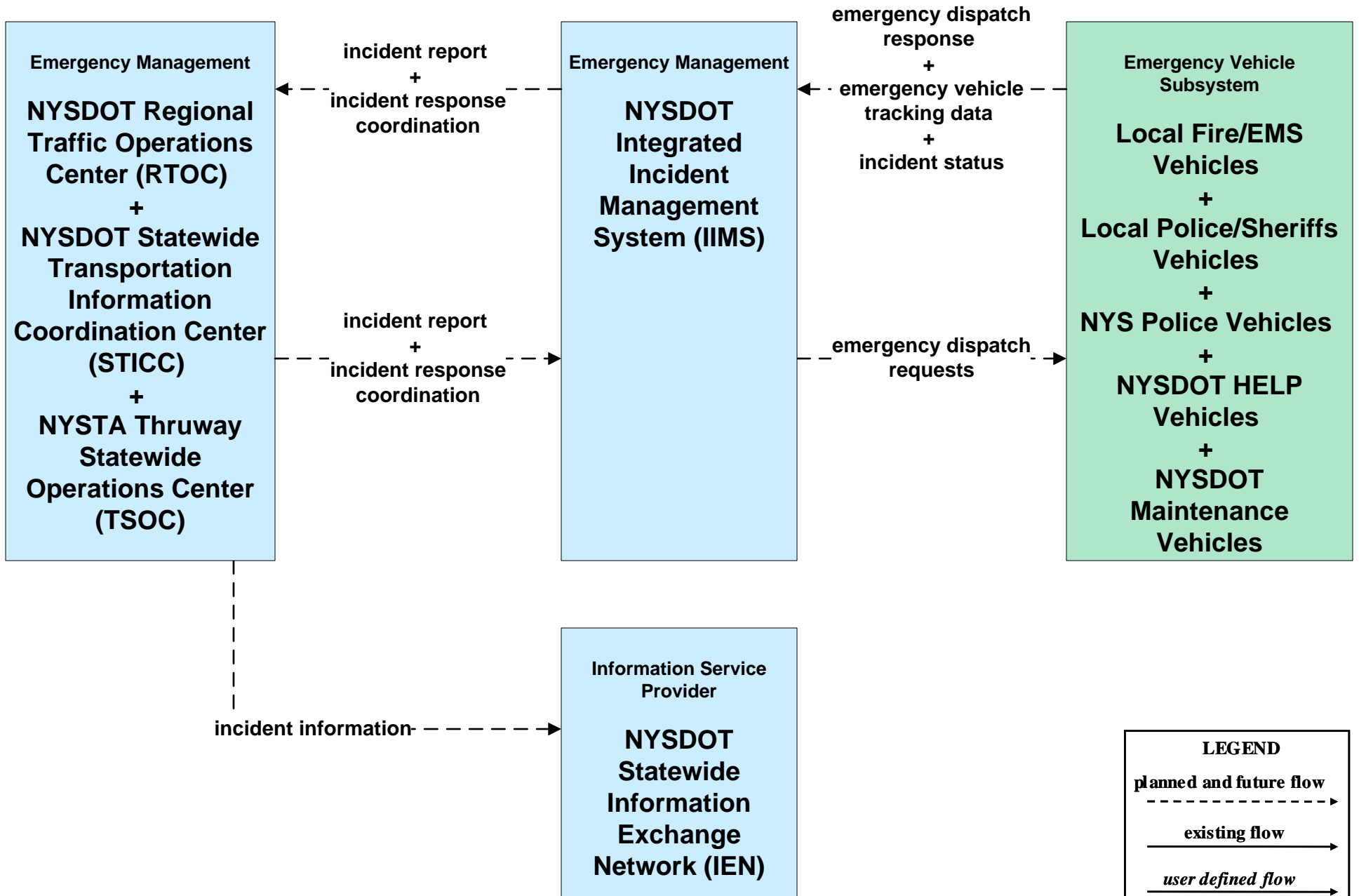

**EM05 - Transportation Infrastructure Protection  
 NYSDOT RTOCs / IEN (2 of 2)**

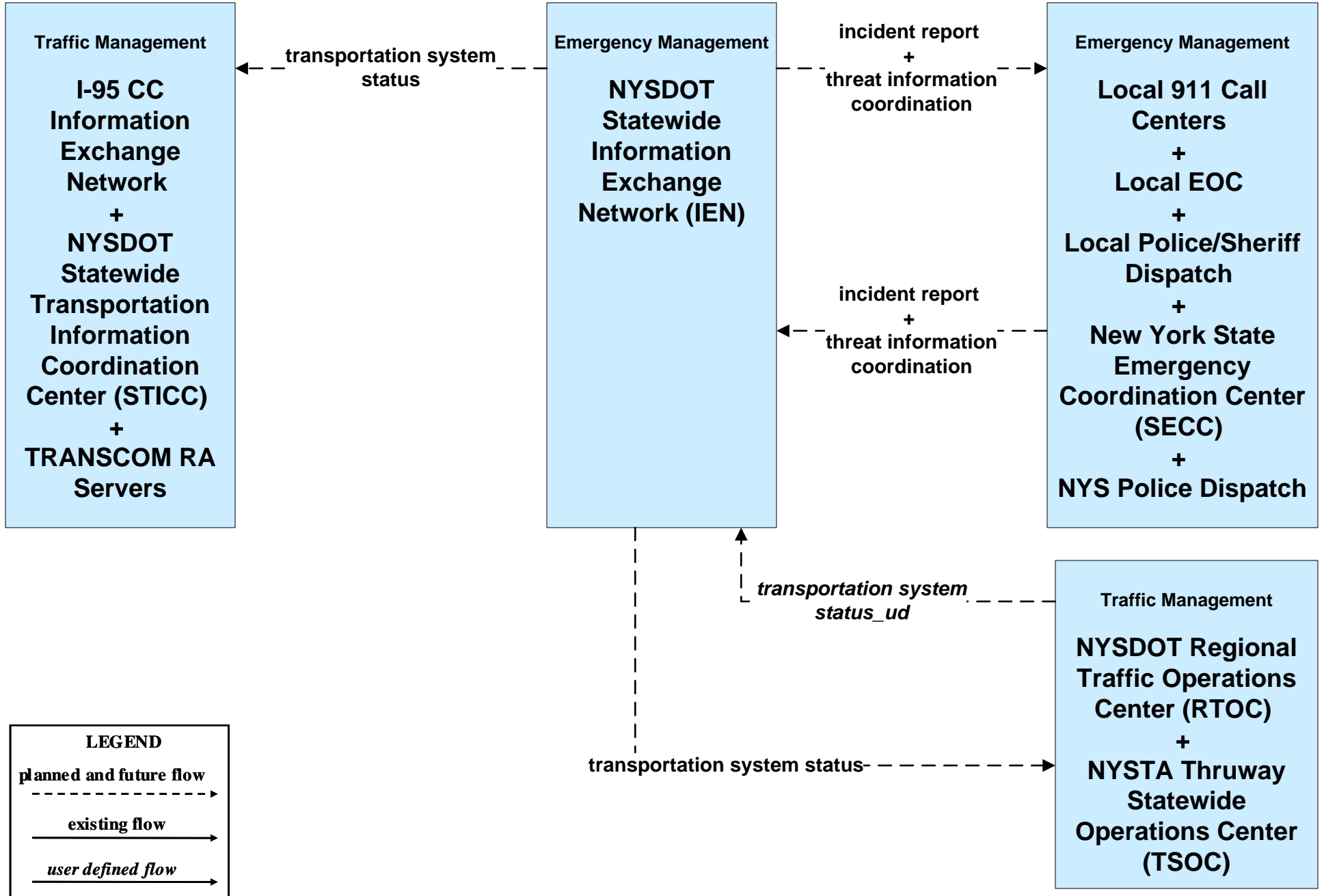

**EM06 - Wide Area Alert  
NYSDOT IEN**

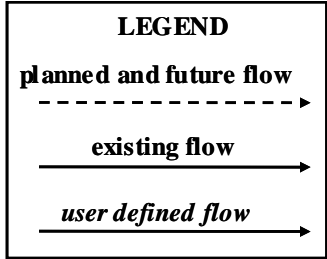
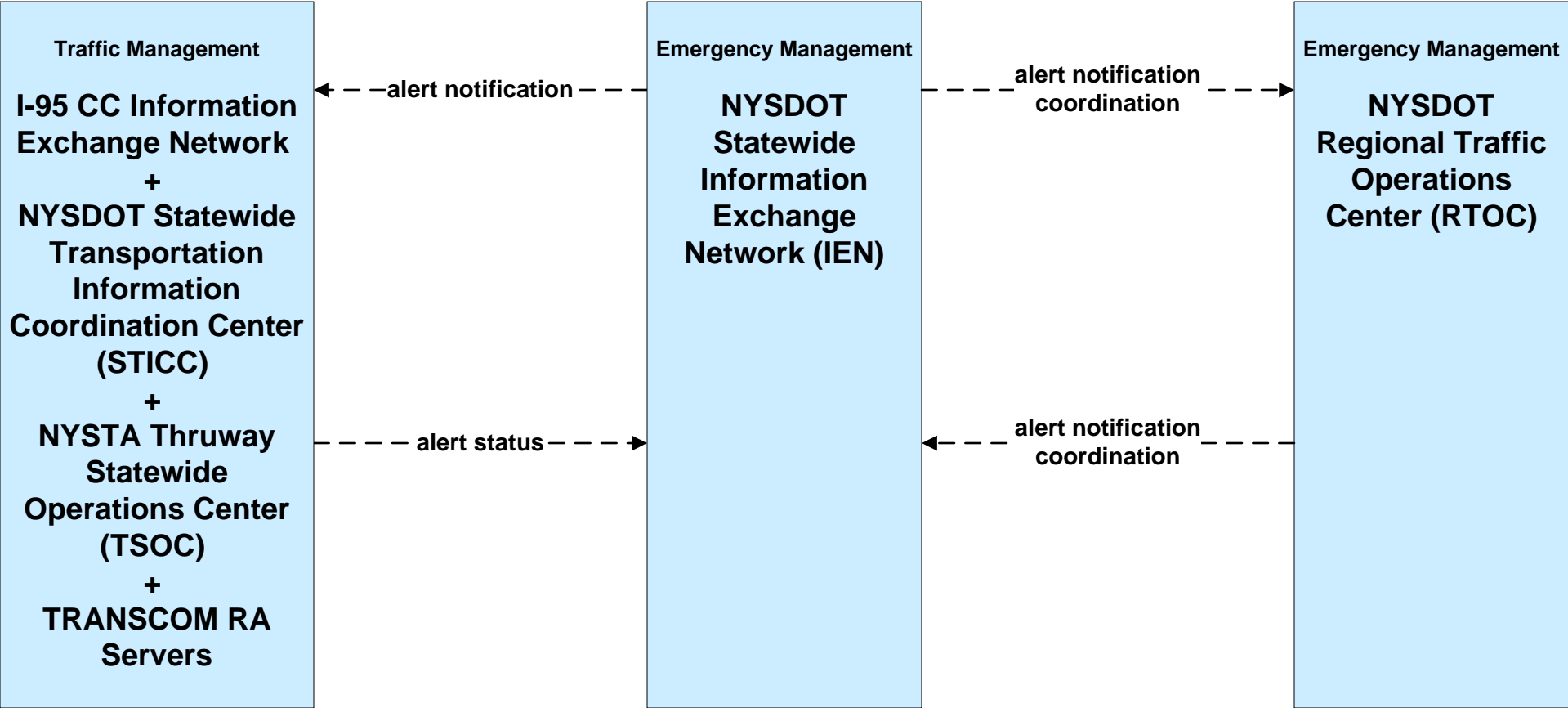



**EM07 – Early Warning System  
NYSDOT IEN**

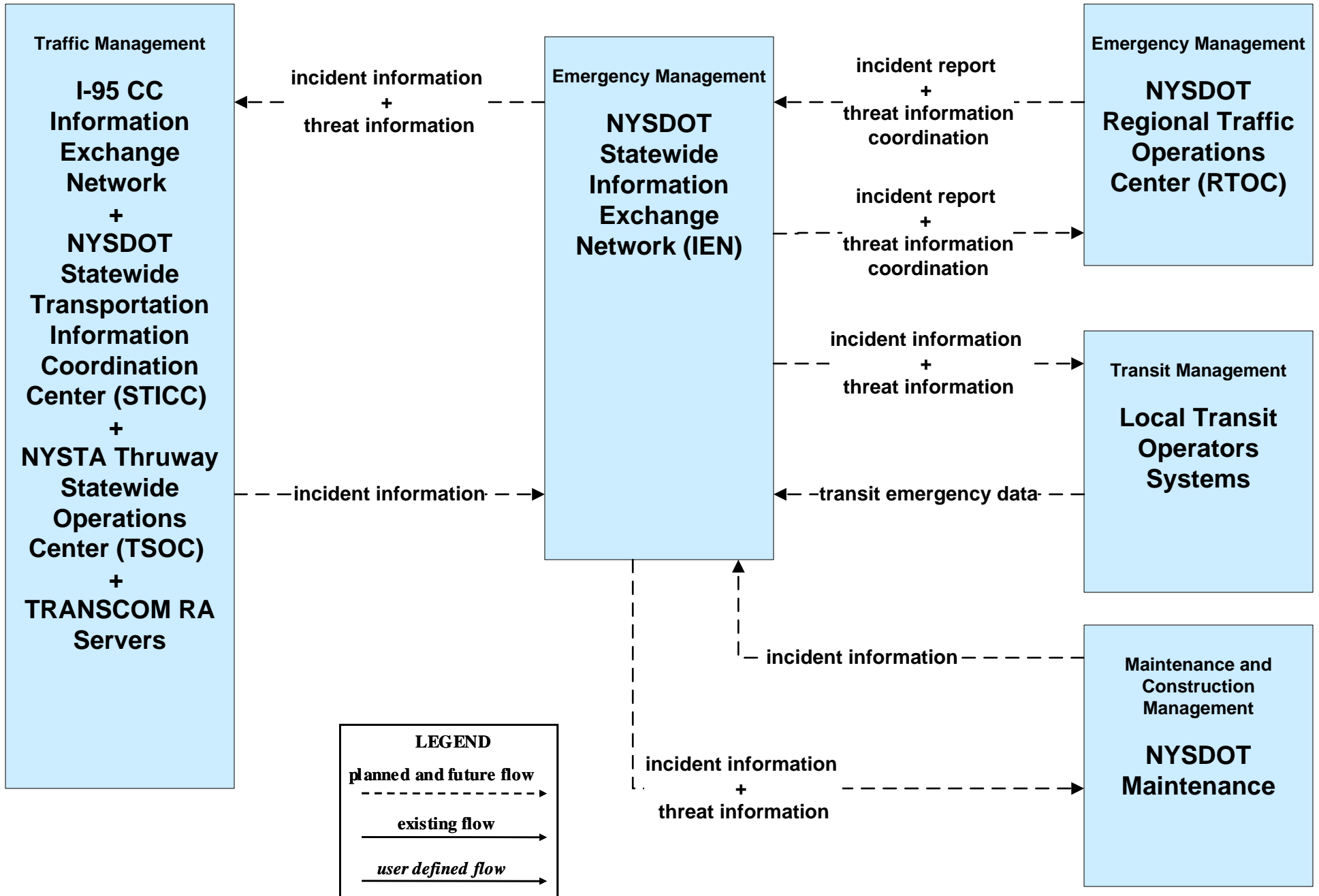

**EM08 – Disaster Recovery and Response  
 NYSDOT IEN**

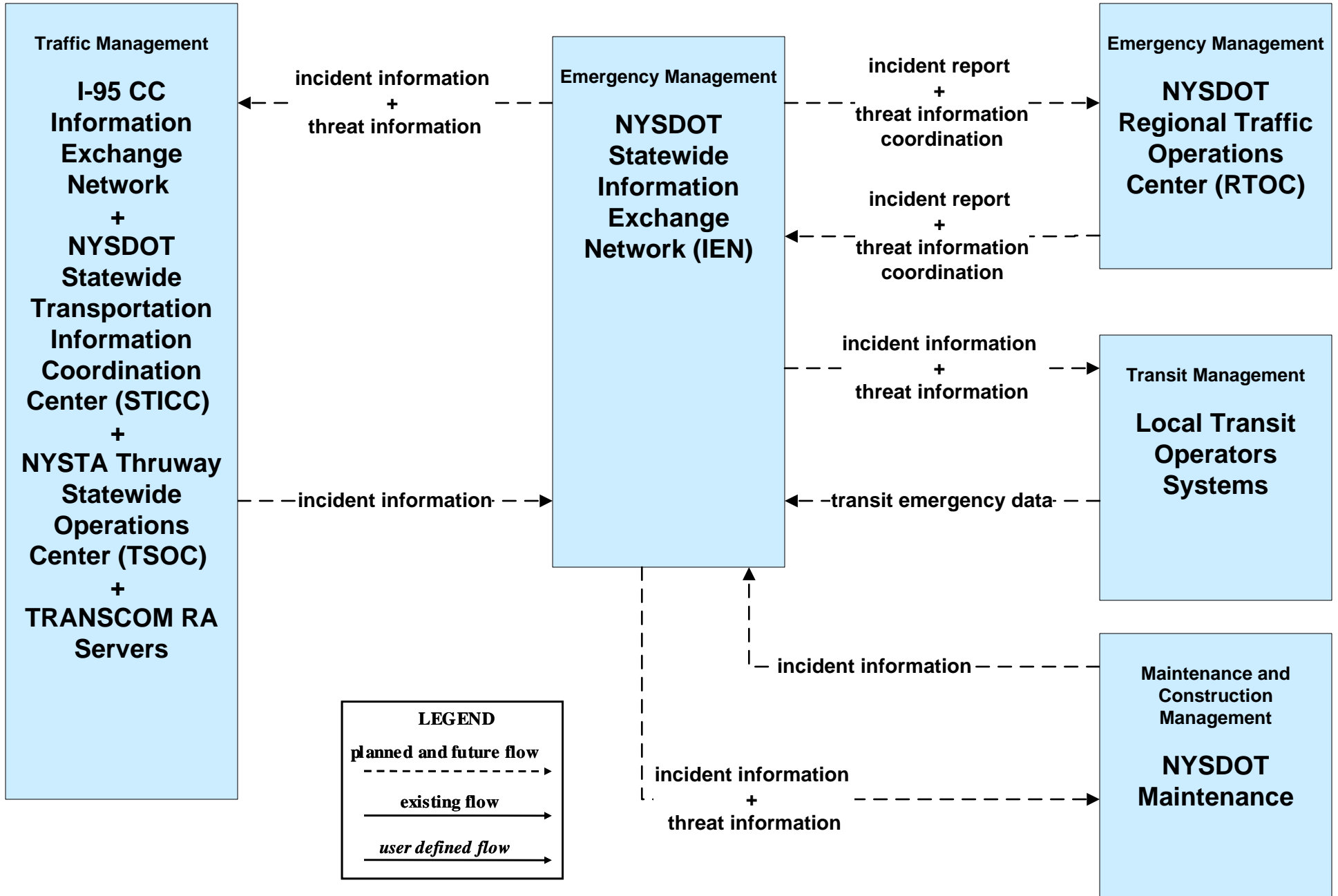

**EM09 – Evacuation and Reentry Management  
NYSDOT IEN**

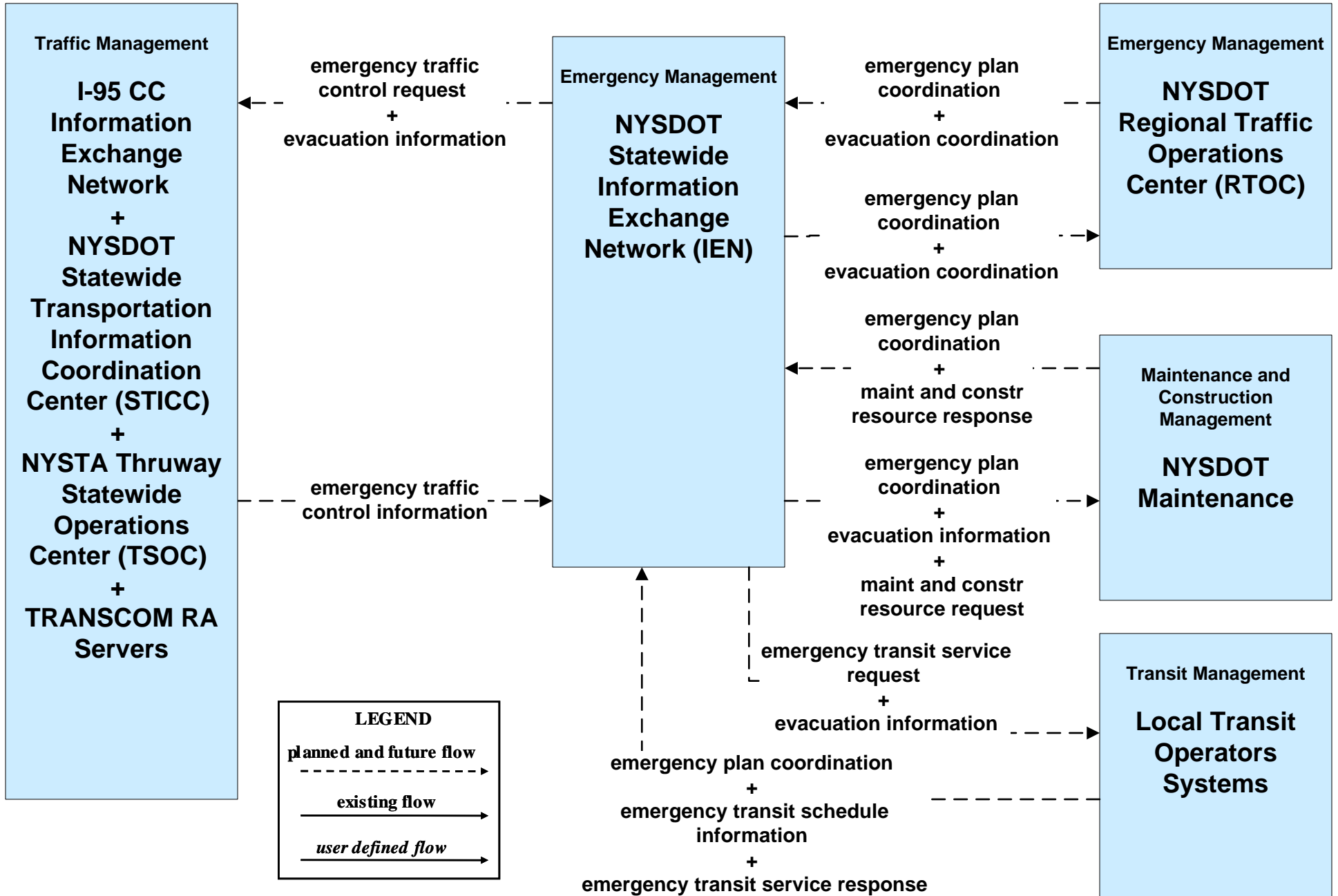

**EM10 - Disaster Traveler Information  
 NYSDOT IEN and NY511.ORG**

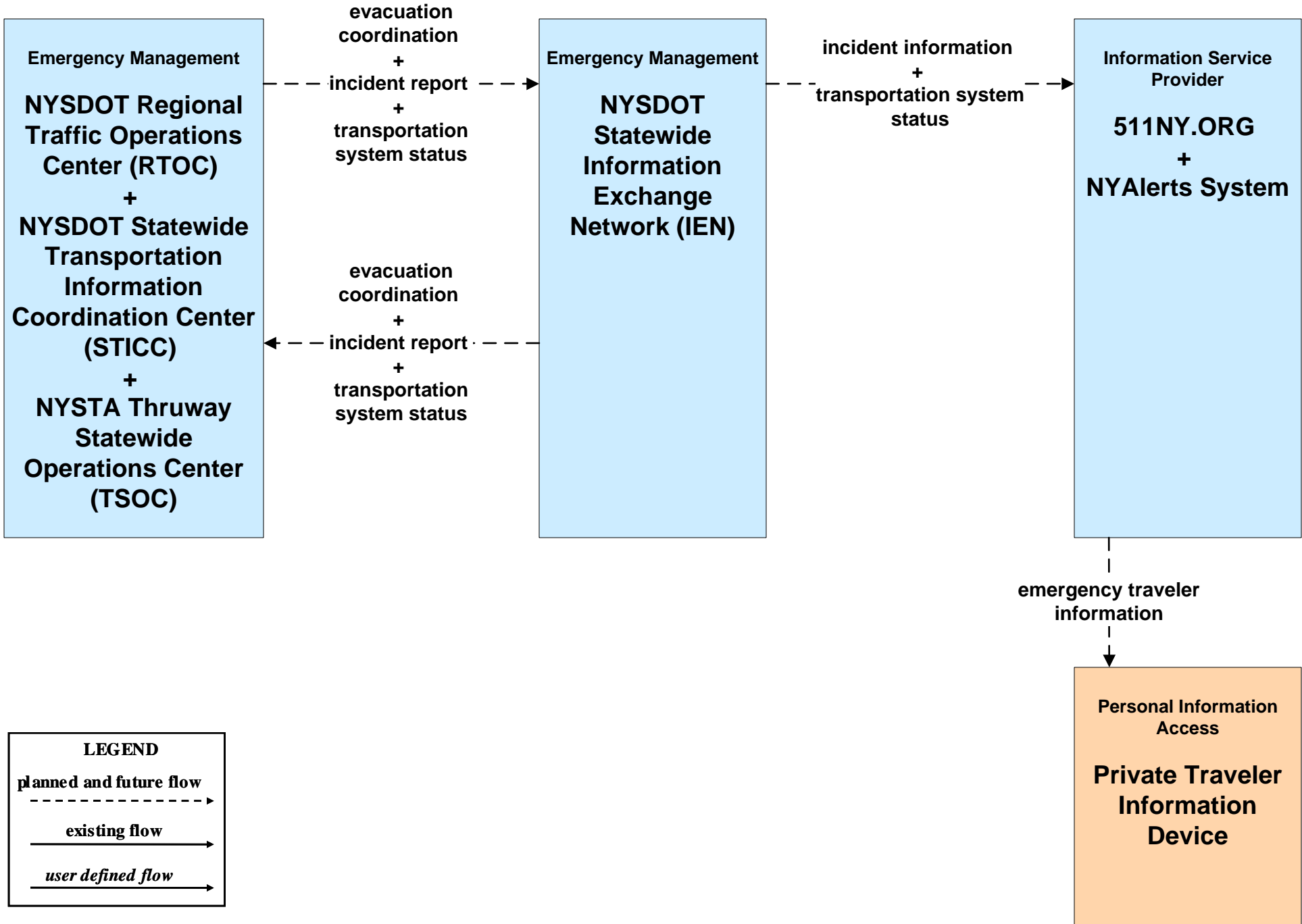

**MC01 - Maintenance and Construction Vehicle Tracking  
NYSTA**

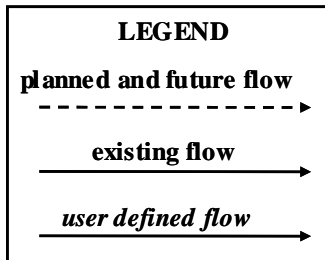
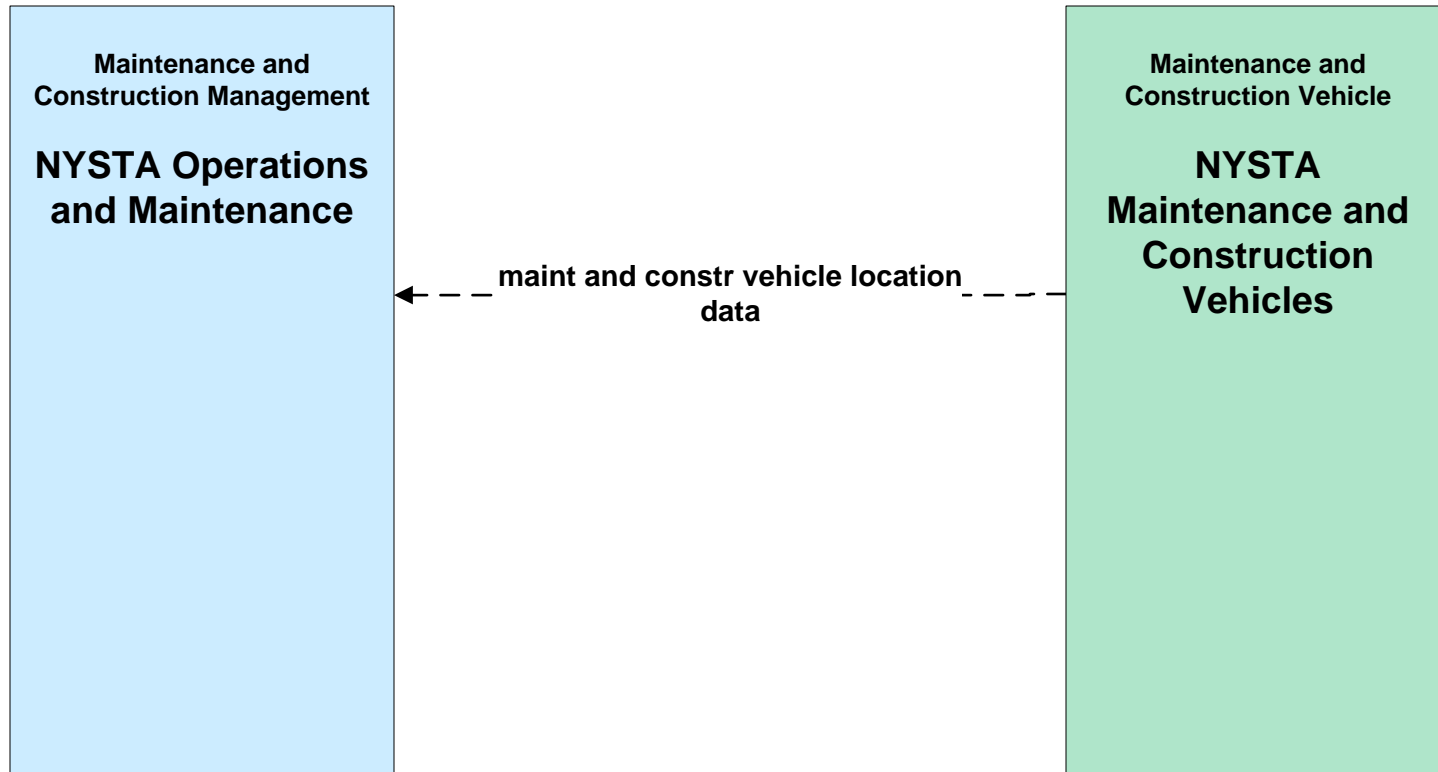

**MC02 - Maintenance and Construction Vehicle Maintenance  
NYSTA**

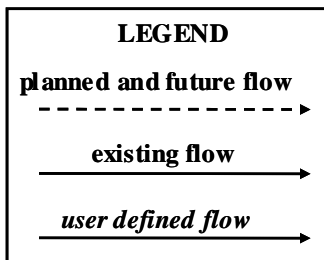
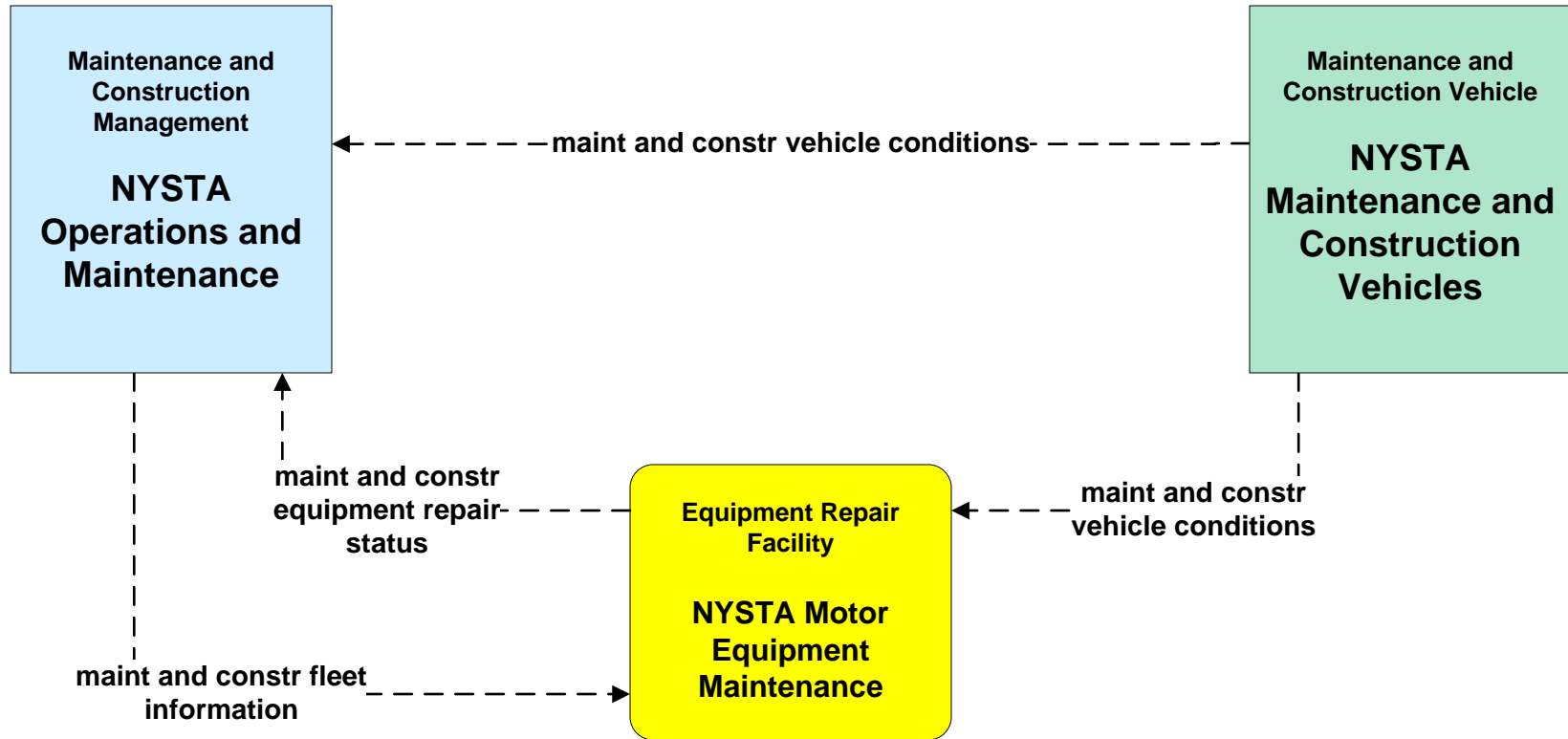

**MC03 – Road Weather Data Collection  
 NYSDOT/NYSTA (1 of 2)**

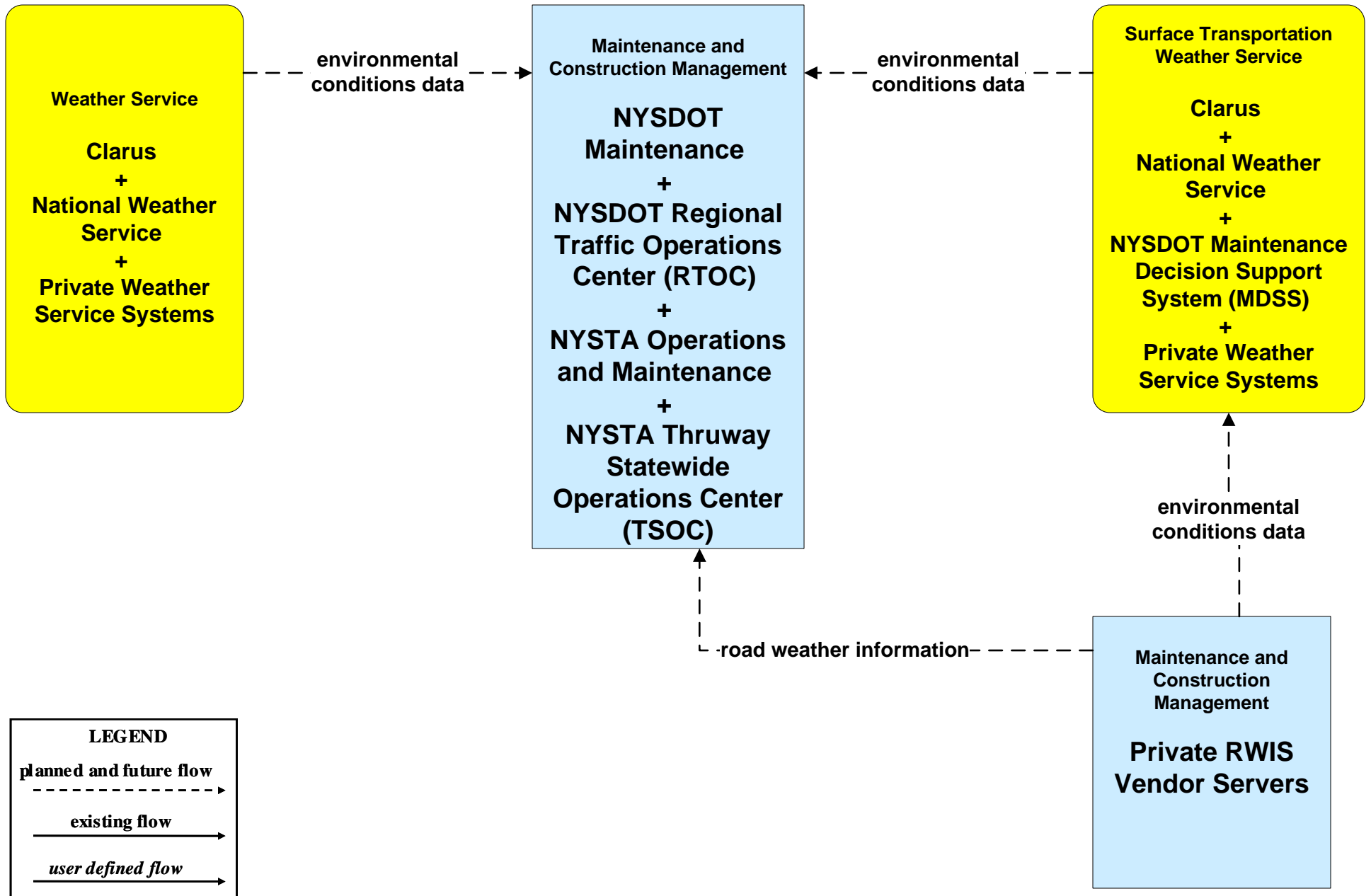

**MC03 – Road Weather Data Collection  
NYSTA**

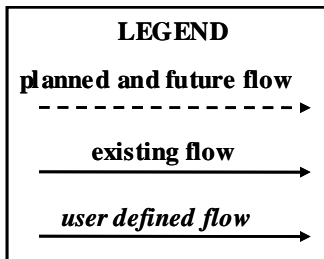
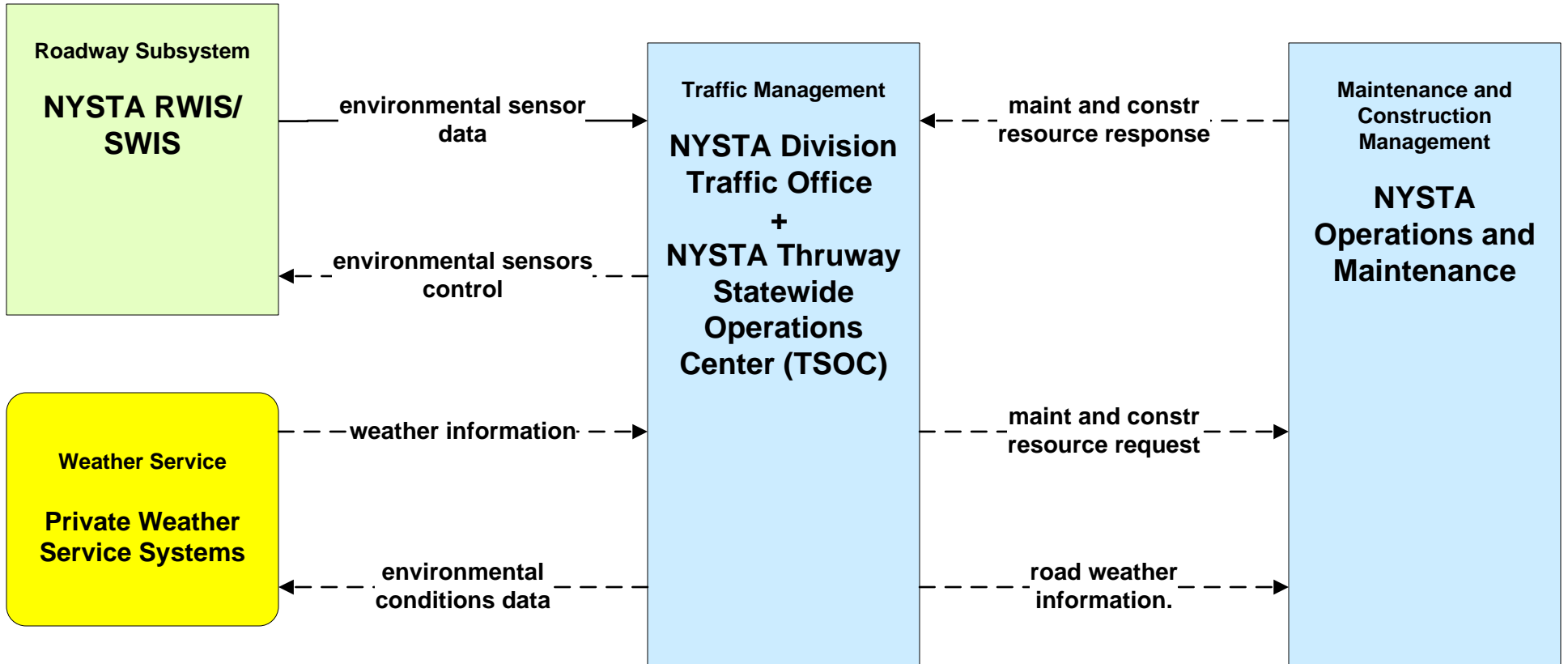



**MC04 – Weather Information Processing and Distribution  
NYSDOT (2 of 2)**

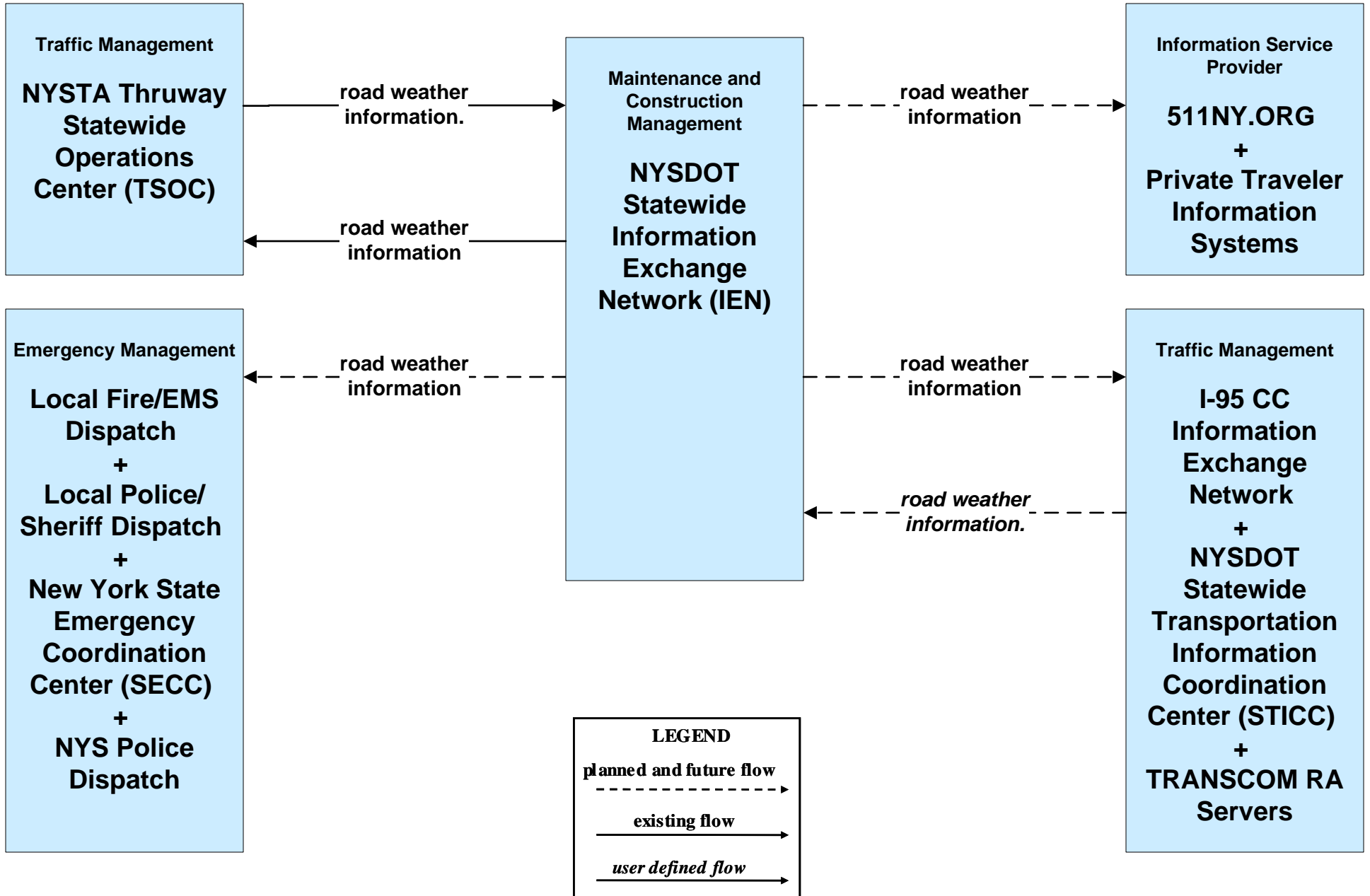

**MC04 – Weather Information Processing and Distribution  
NYSTA**

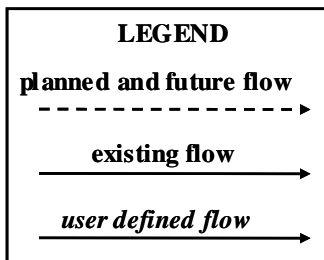
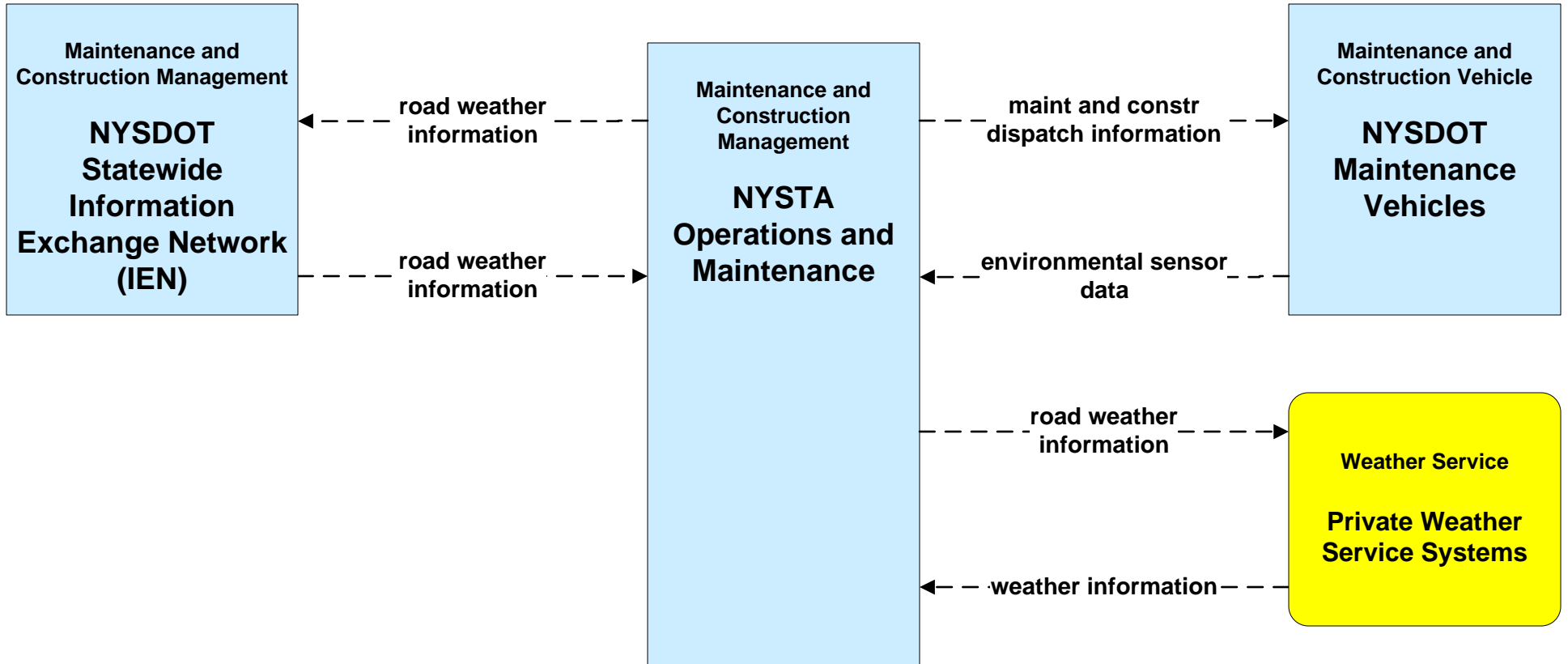

**MC06 – Winter Maintenance  
 NYSDOT (2 of 3)**

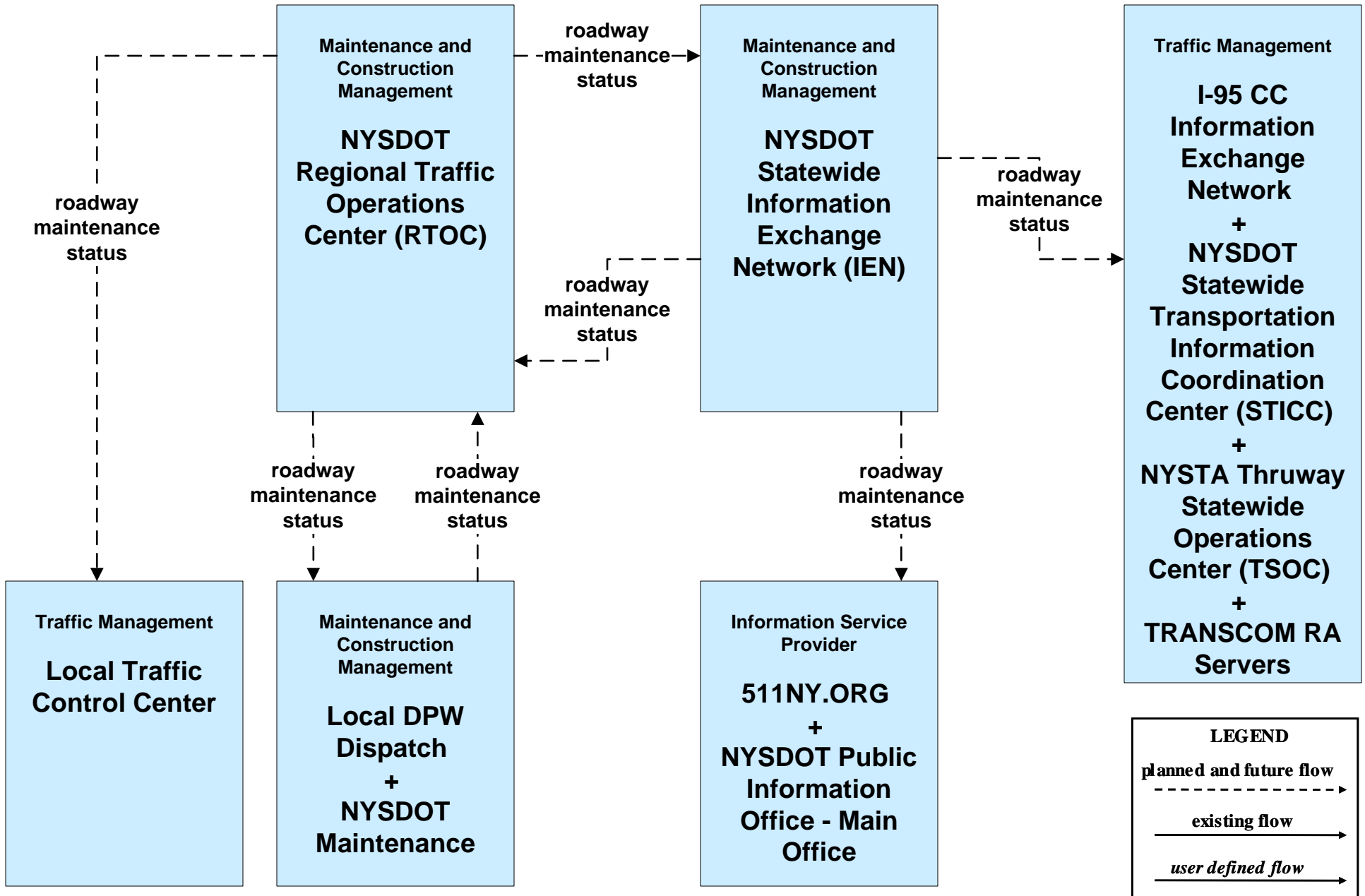

**MC06 – Winter Maintenance  
NYSTA**

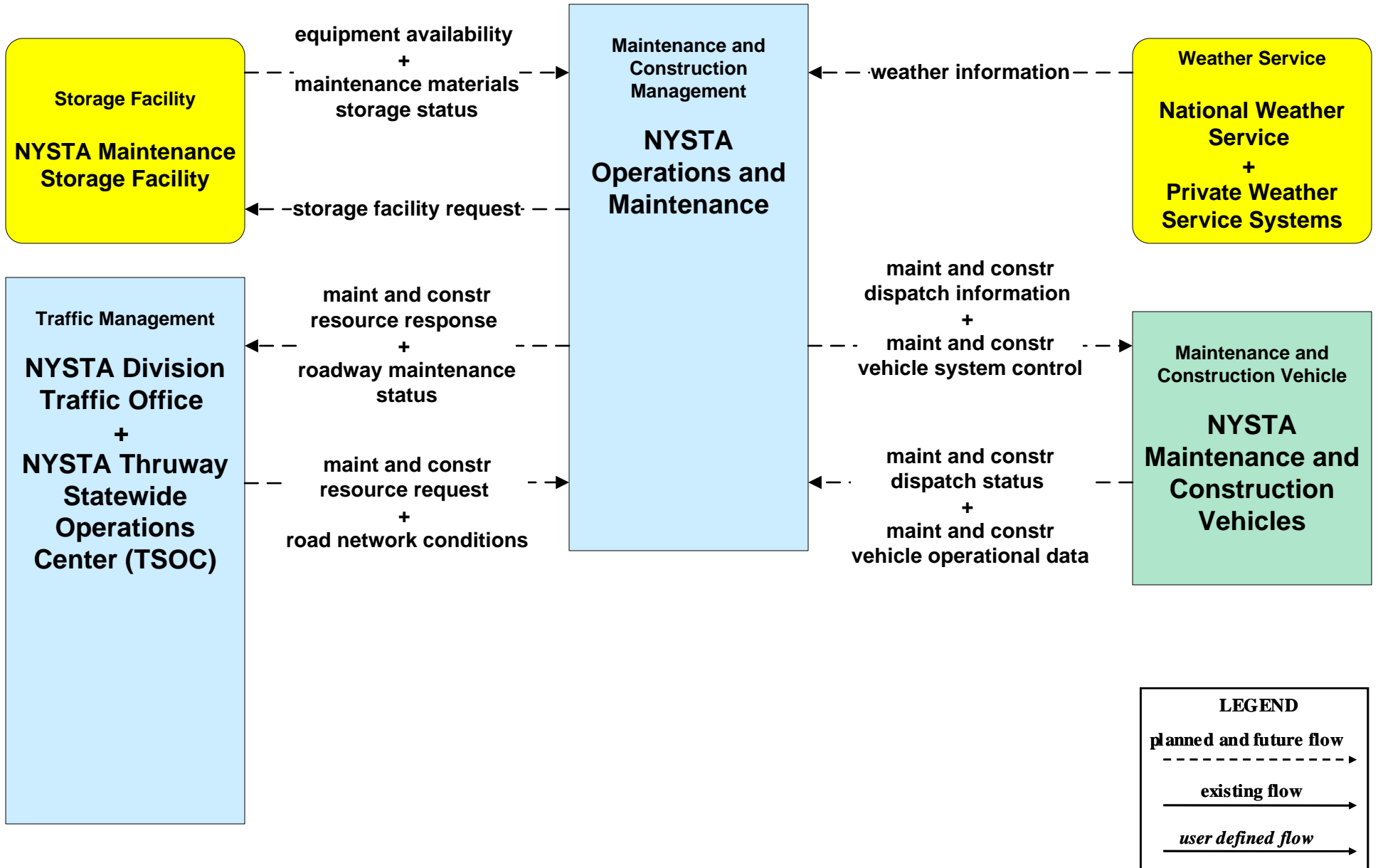

**MC07 - Roadway Maintenance and Construction  
NYSTA**

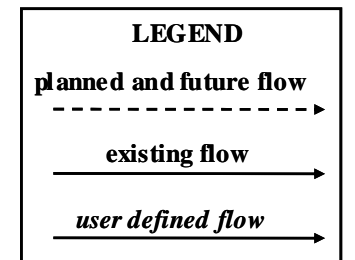
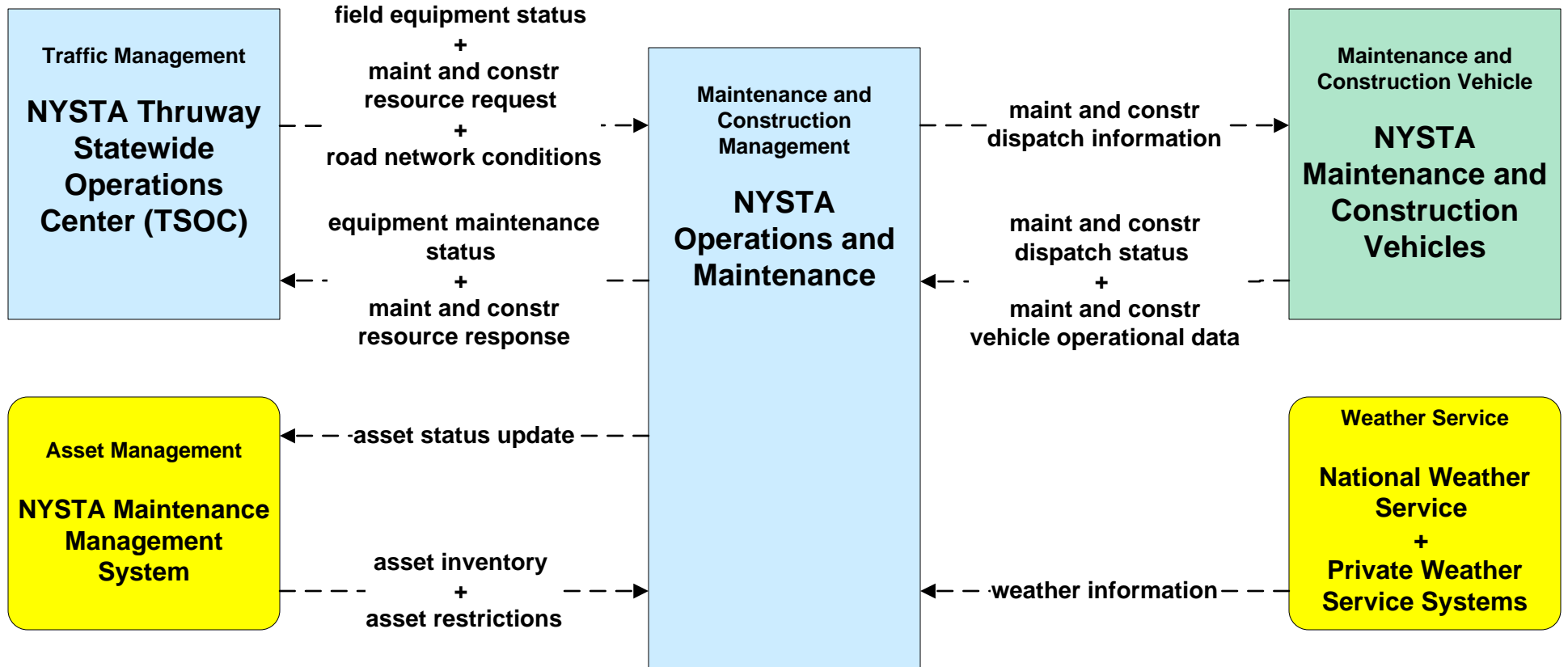

**MC08 - Workzone Management  
NYSTA**

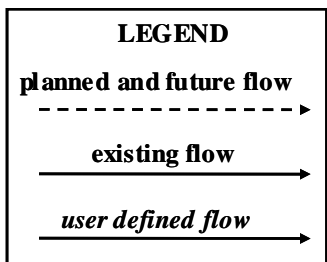
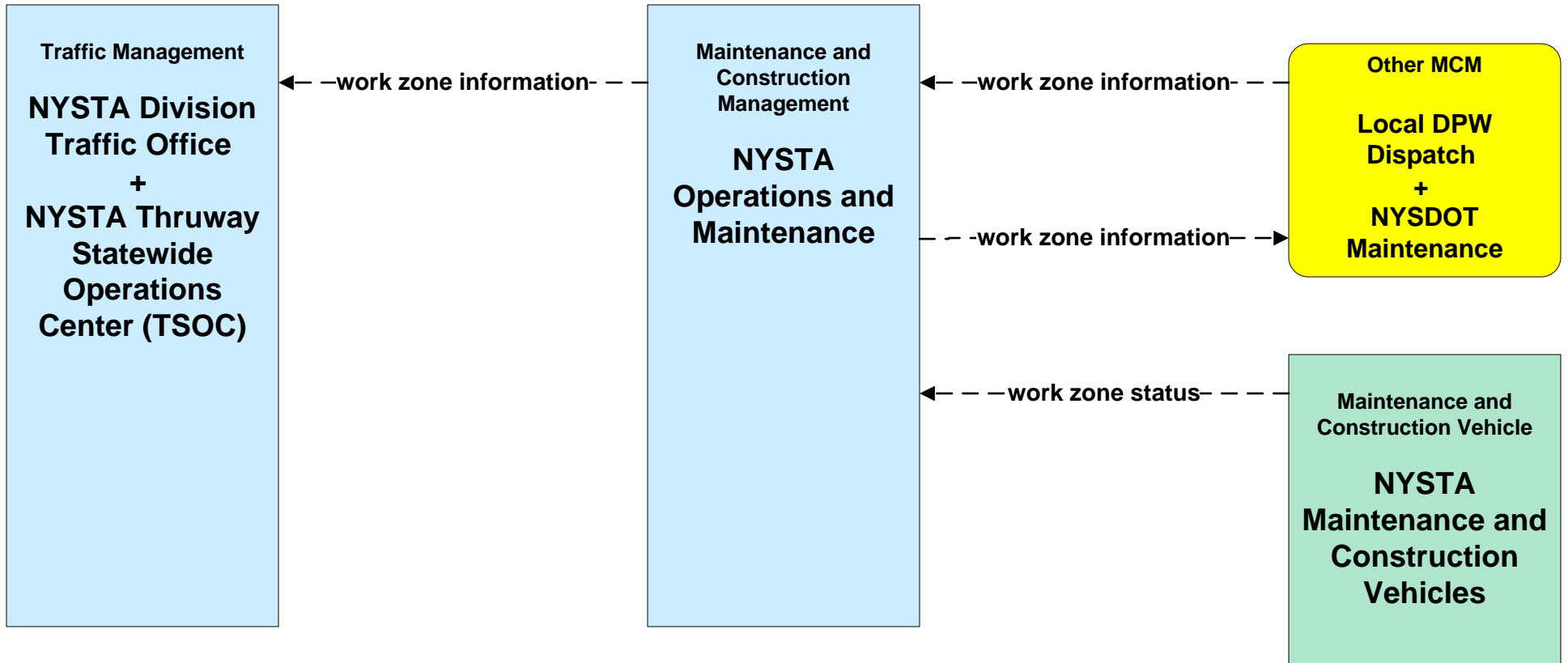

**MC09 - Workzone Safety Monitoring  
NYSTA**

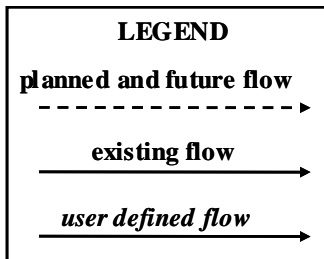
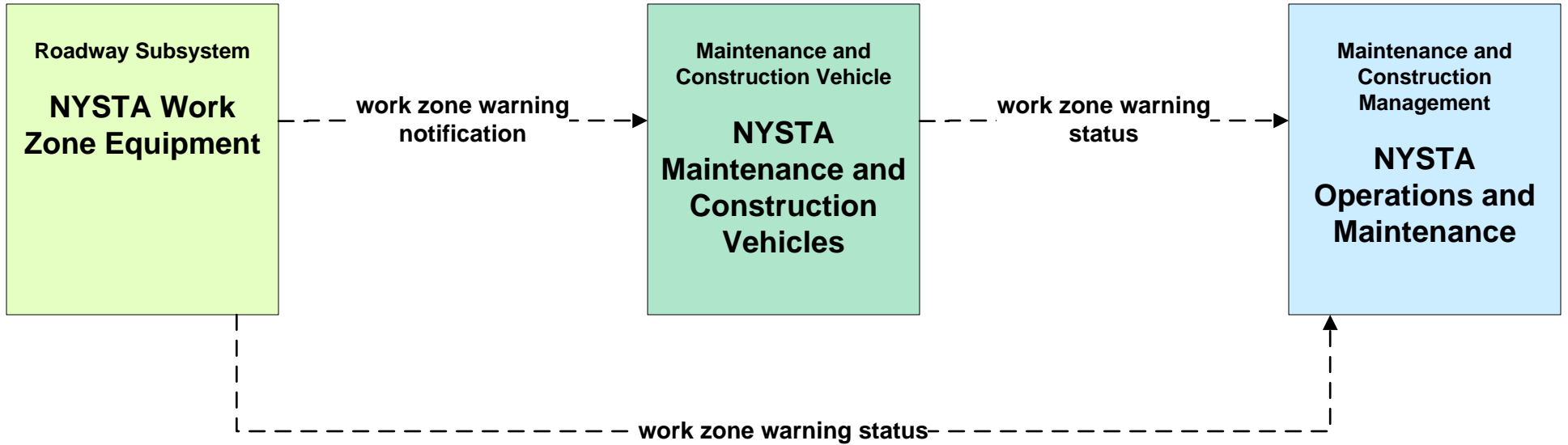

**MC10 – Maintenance and Construction Activity Coordination  
NYSDOT**

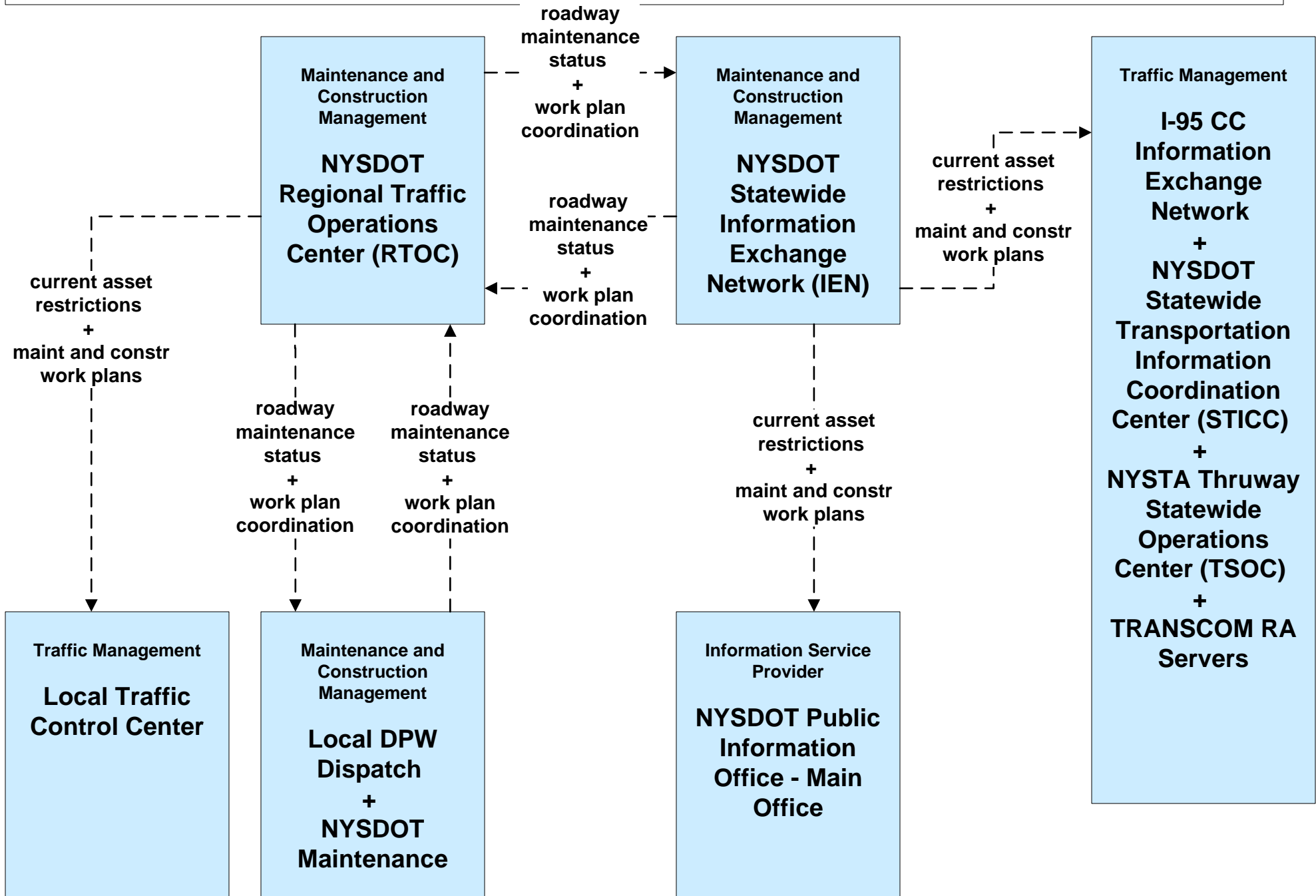



**MC10 – Maintenance and Construction Activity Coordination  
NYSDOT**

