

# **New York Statewide Services ITS Architecture**

**Customized Market Package Diagrams**

**Advanced Traffic Management Systems  
(ATMS)**

**ATMS01 - Network Surveillance**  
**NYSDOT Regional TOCs / Information Exchange Network (IEN)**

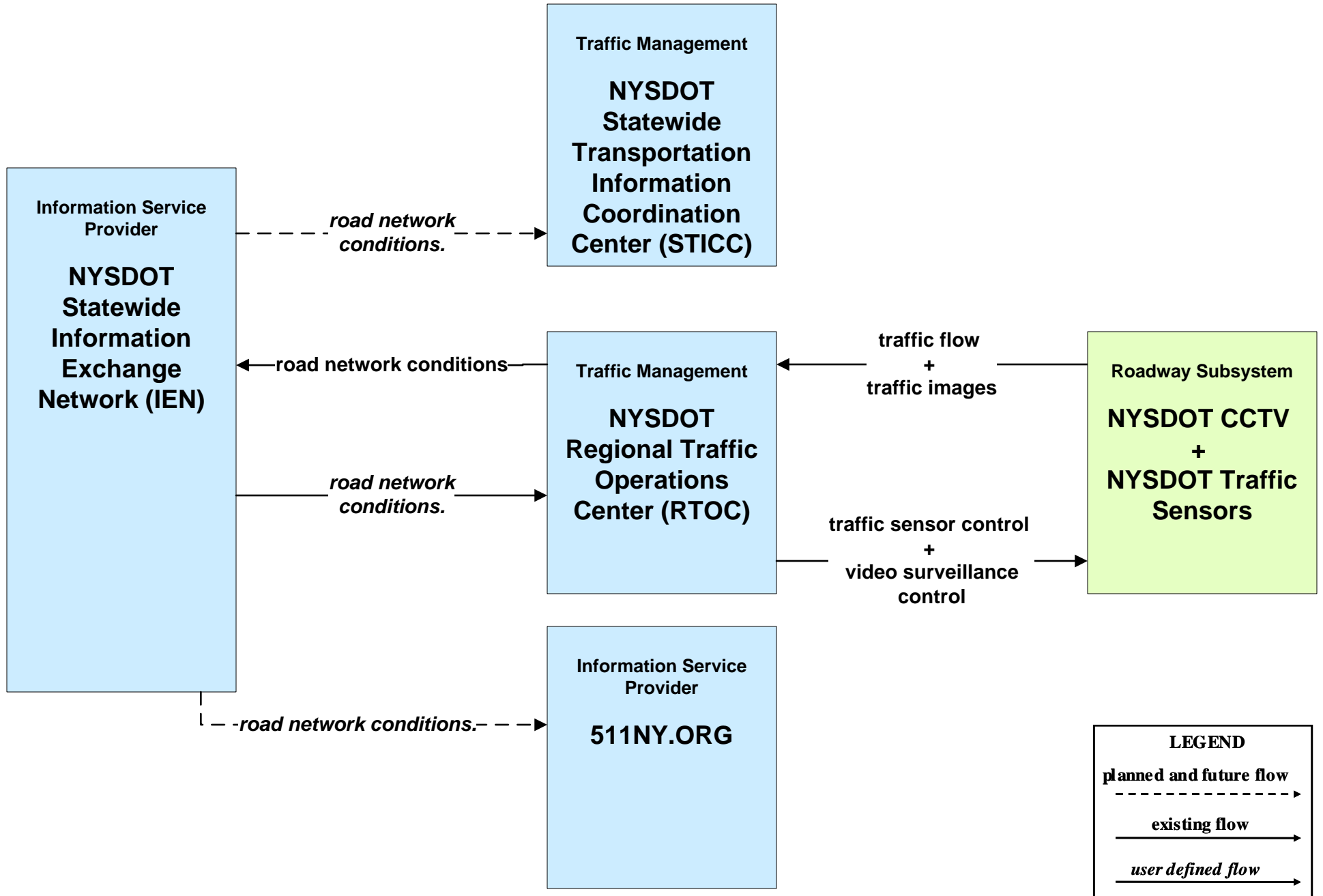

**ATMS01 - Network Surveillance**  
**NYSDOT Regional TOCs / Video Exchange Network (VEN)**

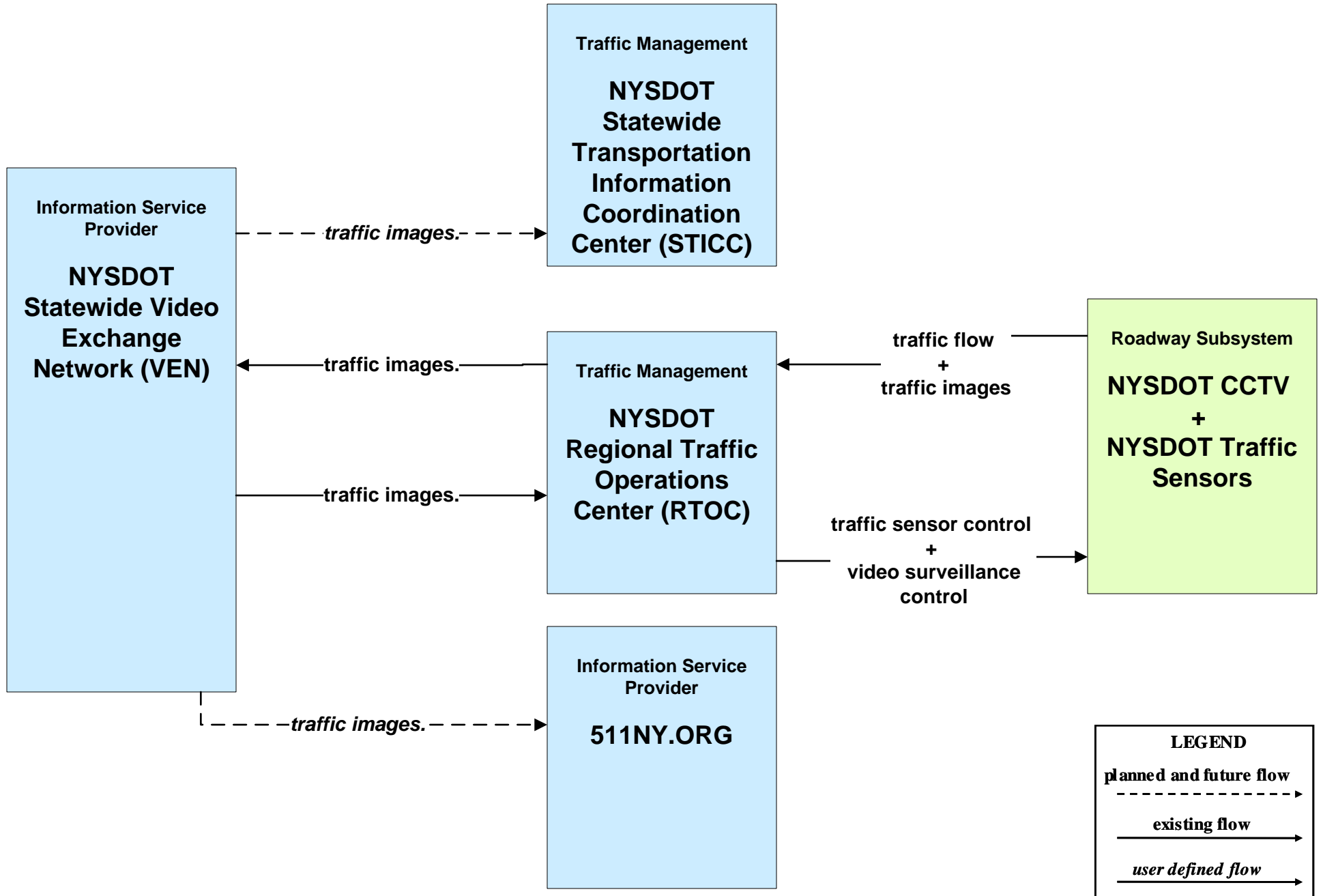

# ATMS01 - Network Surveillance NYSTA

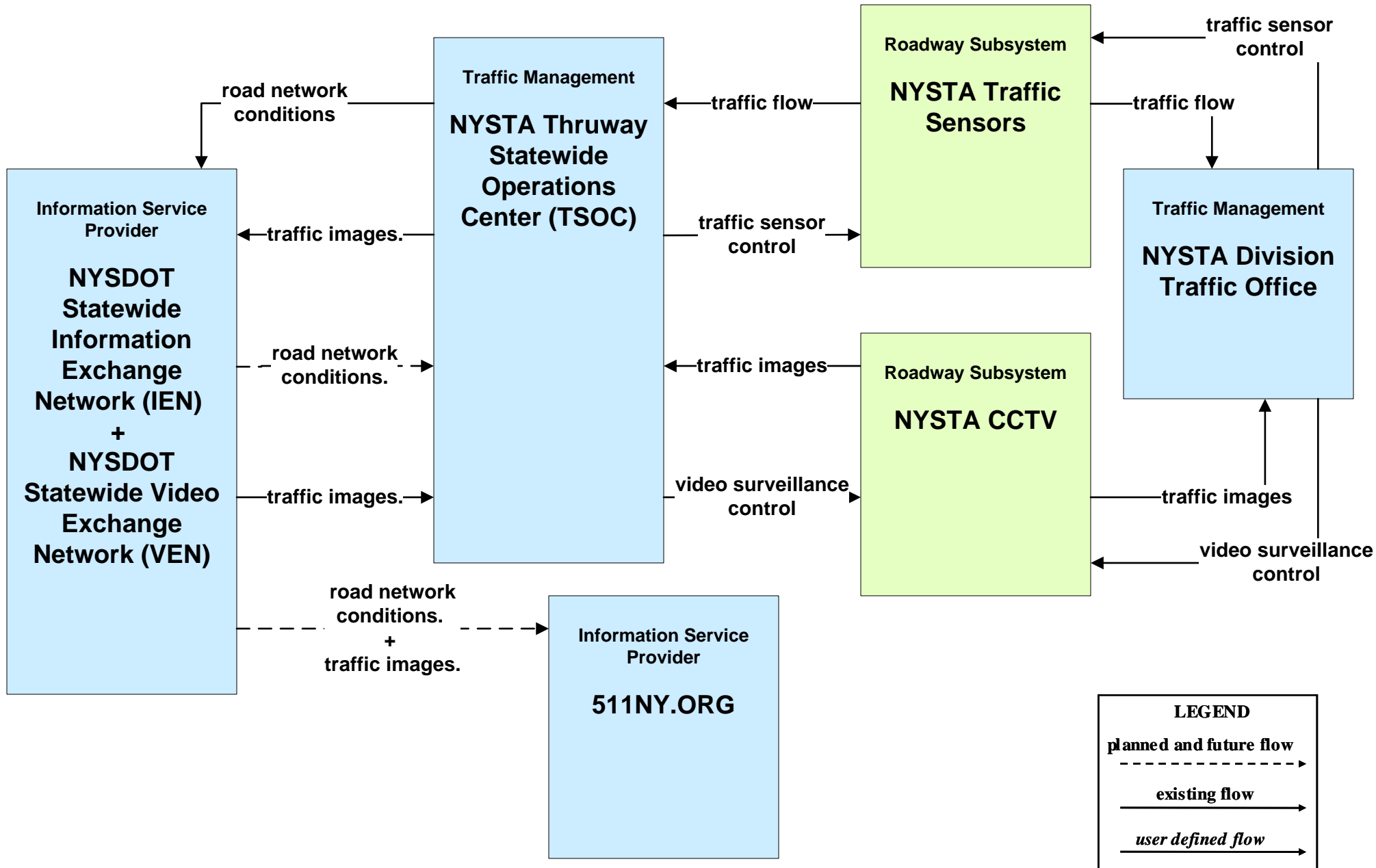

**ATMS02 - Probe Surveillance  
TRANSMIT / NYSDOT IEN**

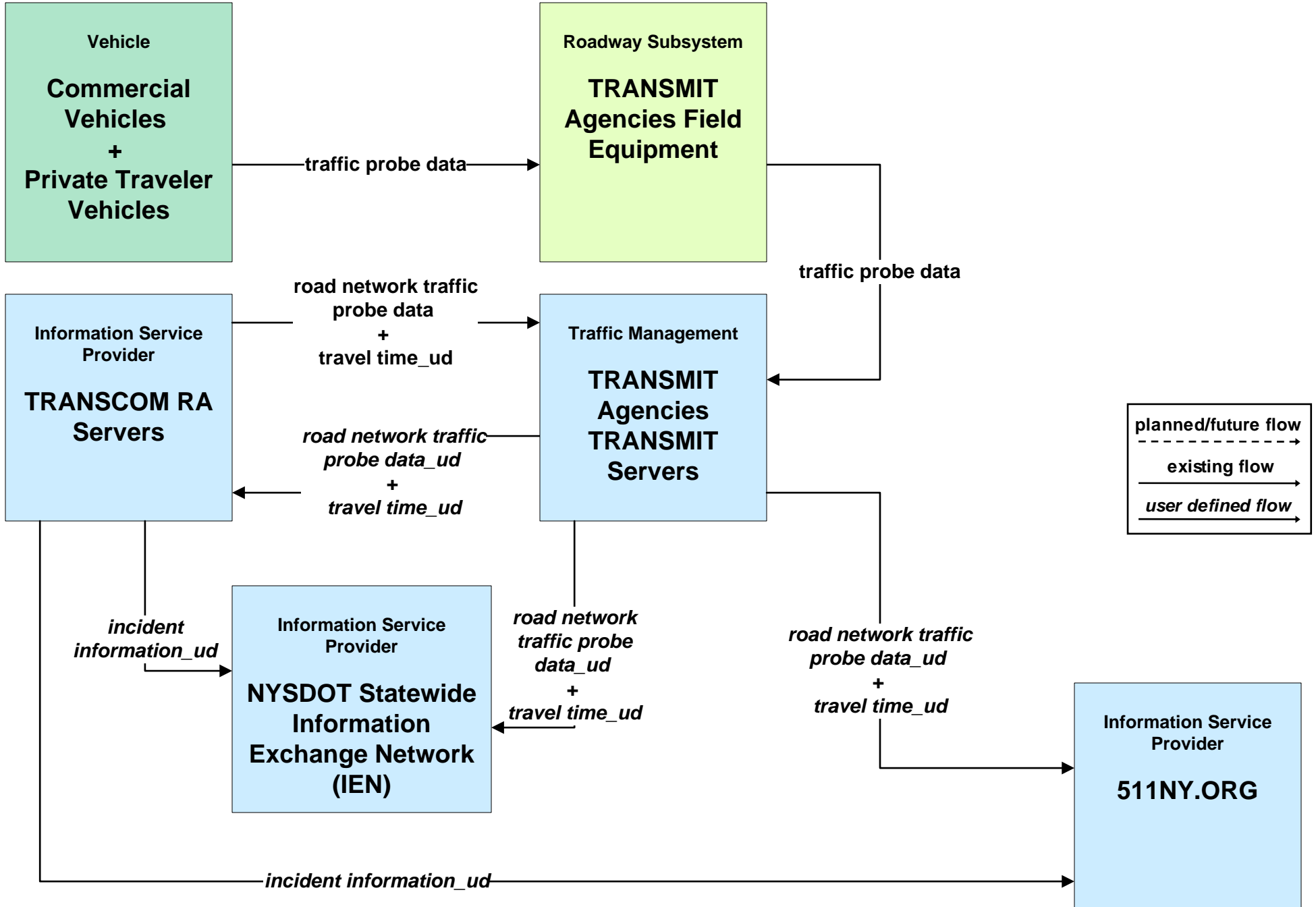

**ATMS03 - Surface Street Control**  
**NYSDOT Regional Traffic Operations Center Traffic Signal Control**

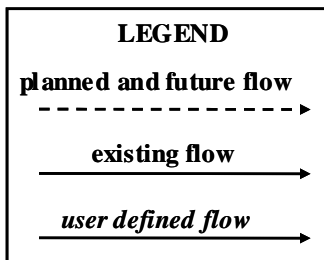
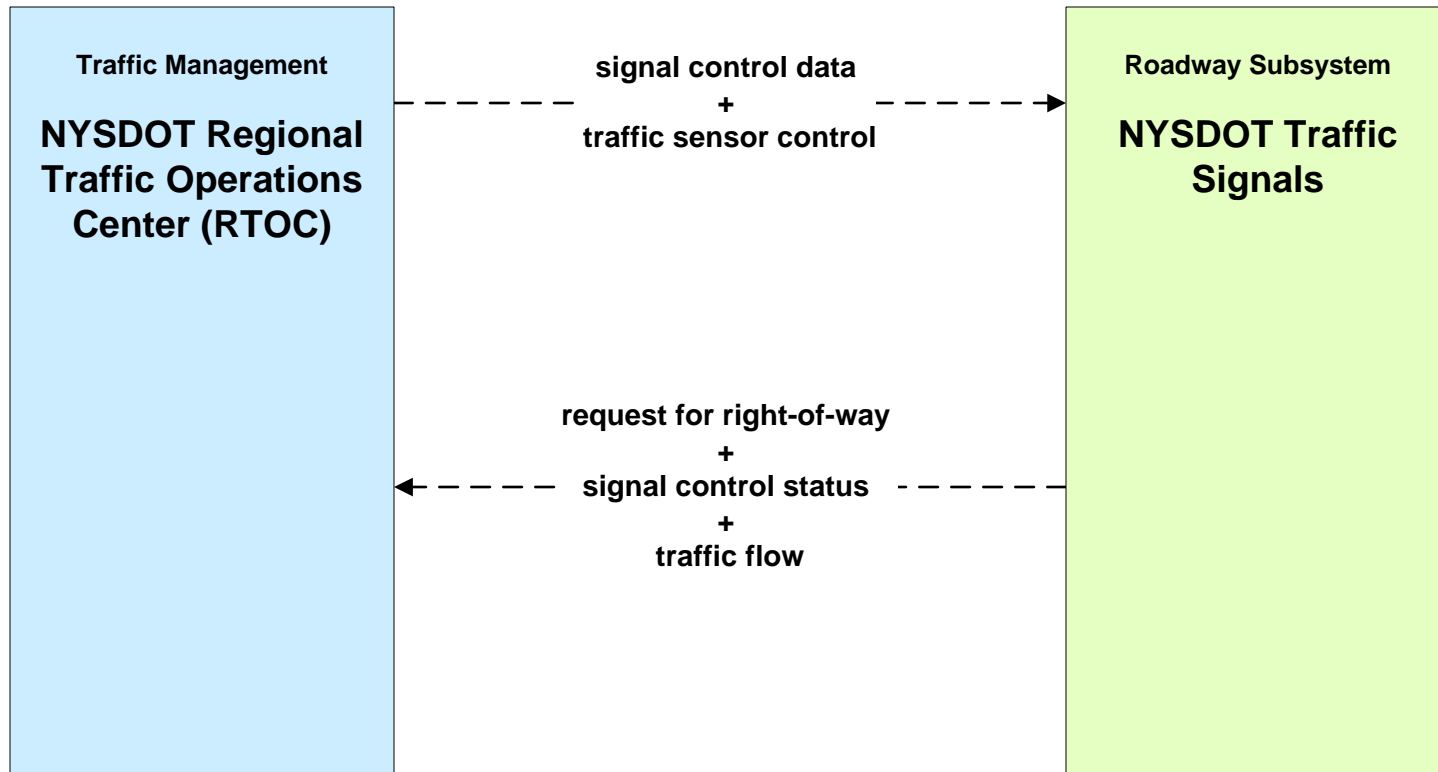

**ATMS03 - Surface Street Control  
NYSDOT Regional Streetwise Servers**

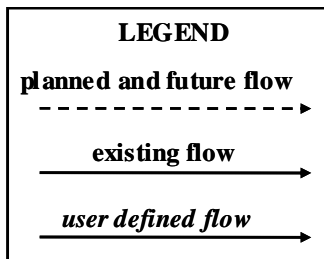
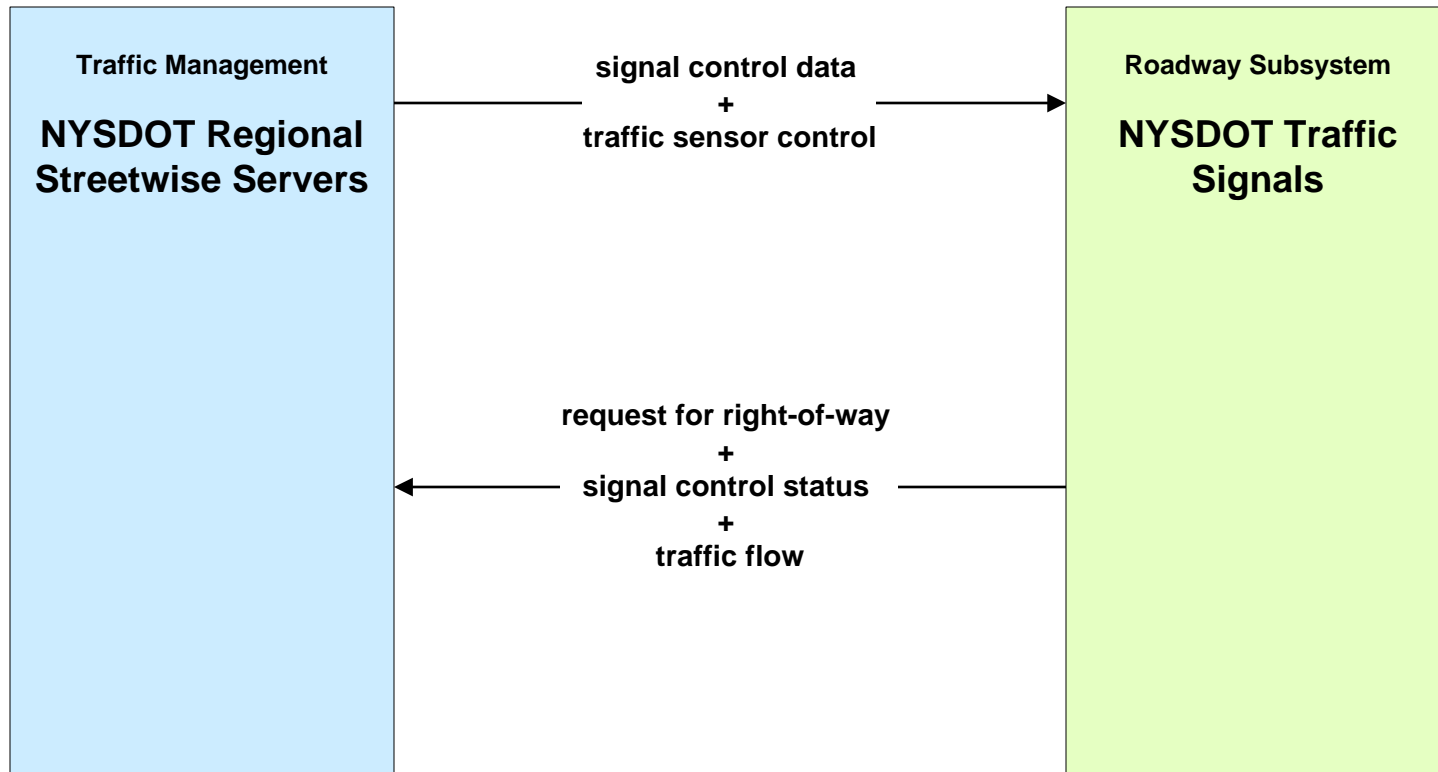

# ATMS04 - Freeway Control NYSTA

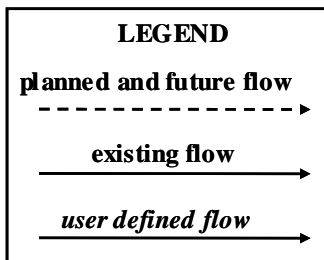
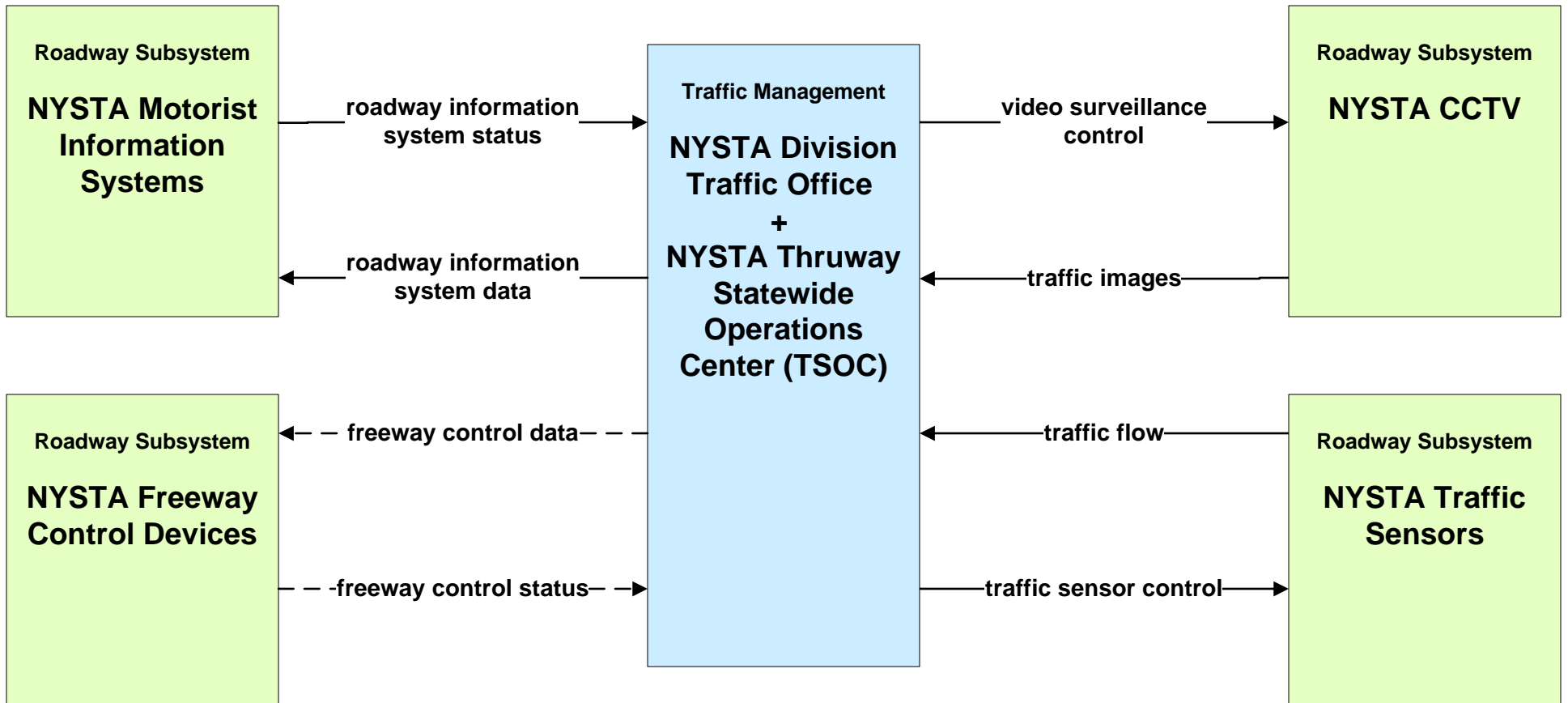



# ATMS06 - Traffic Information Dissemination NYSDOT (1 of 3)

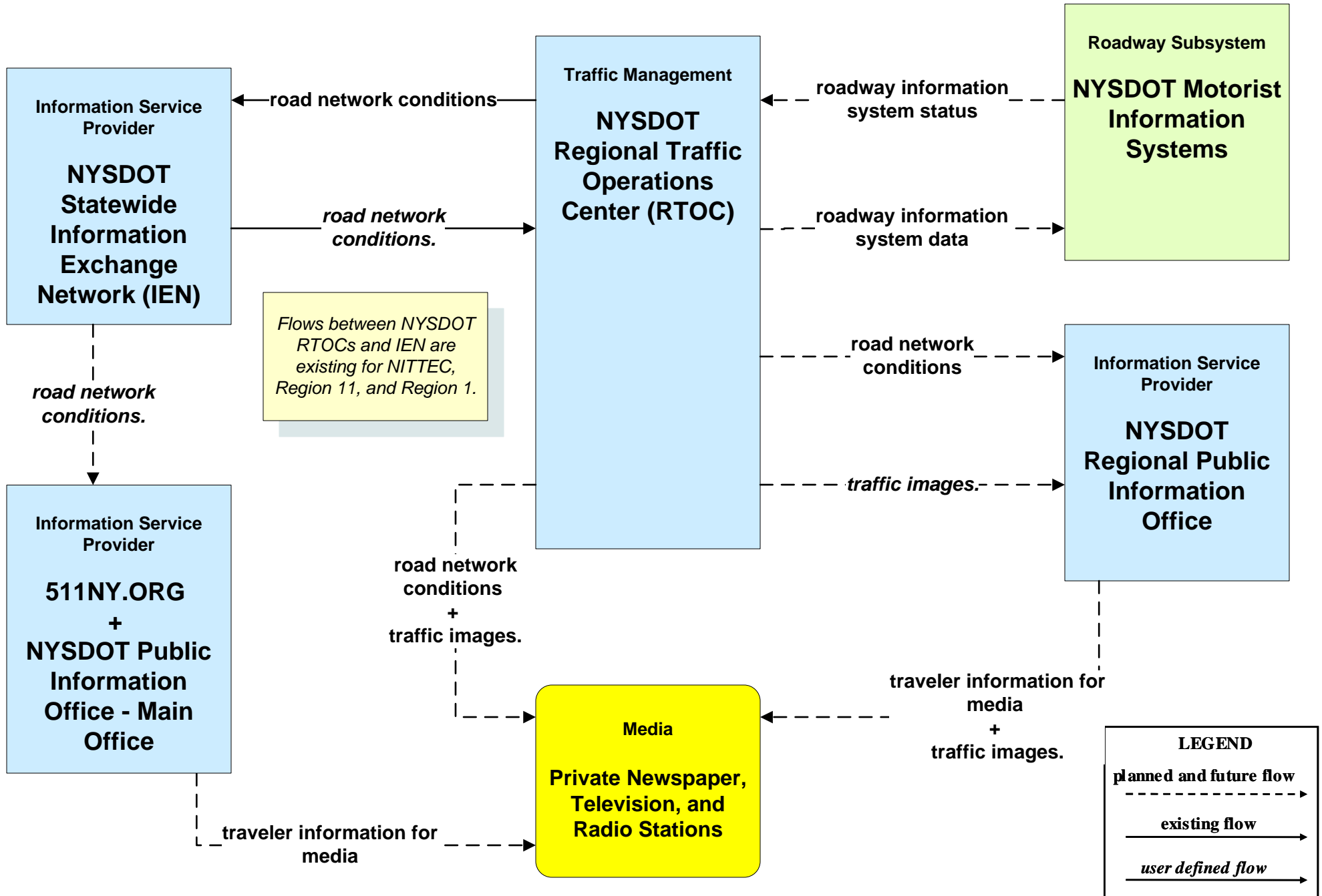

**ATMS06 - Traffic Information Dissemination  
NYSDOT (2 of 3)**

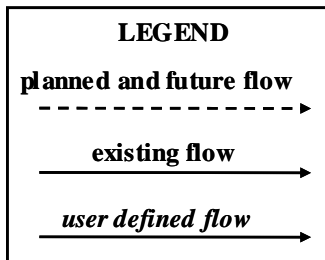
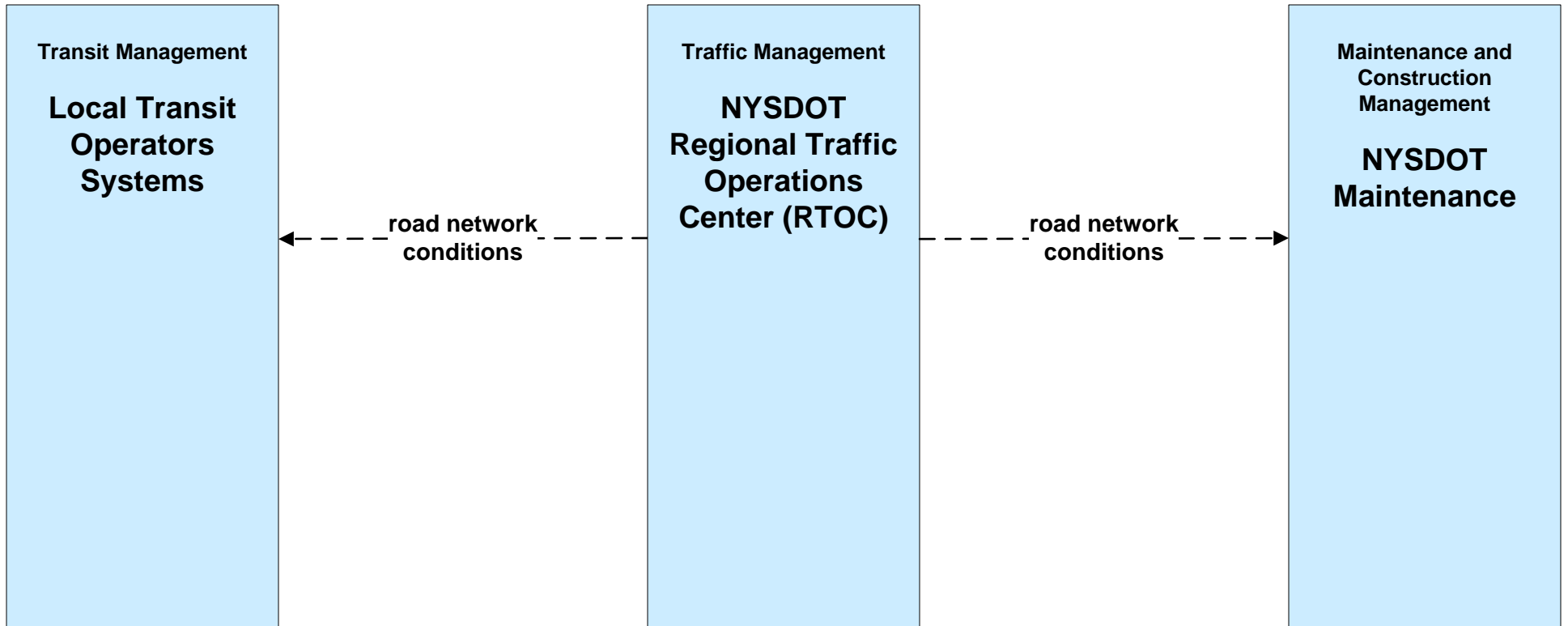

*Region specific whether the local transit operators and/or local maintenance connect directly to the IEN or via the RTOC. The RTOC may have a level of detail that is needed locally, while the IEN will have a higher "big picture" level of detail.*

**ATMS06 - Traffic Information Dissemination  
NYSDOT (3 of 3)**

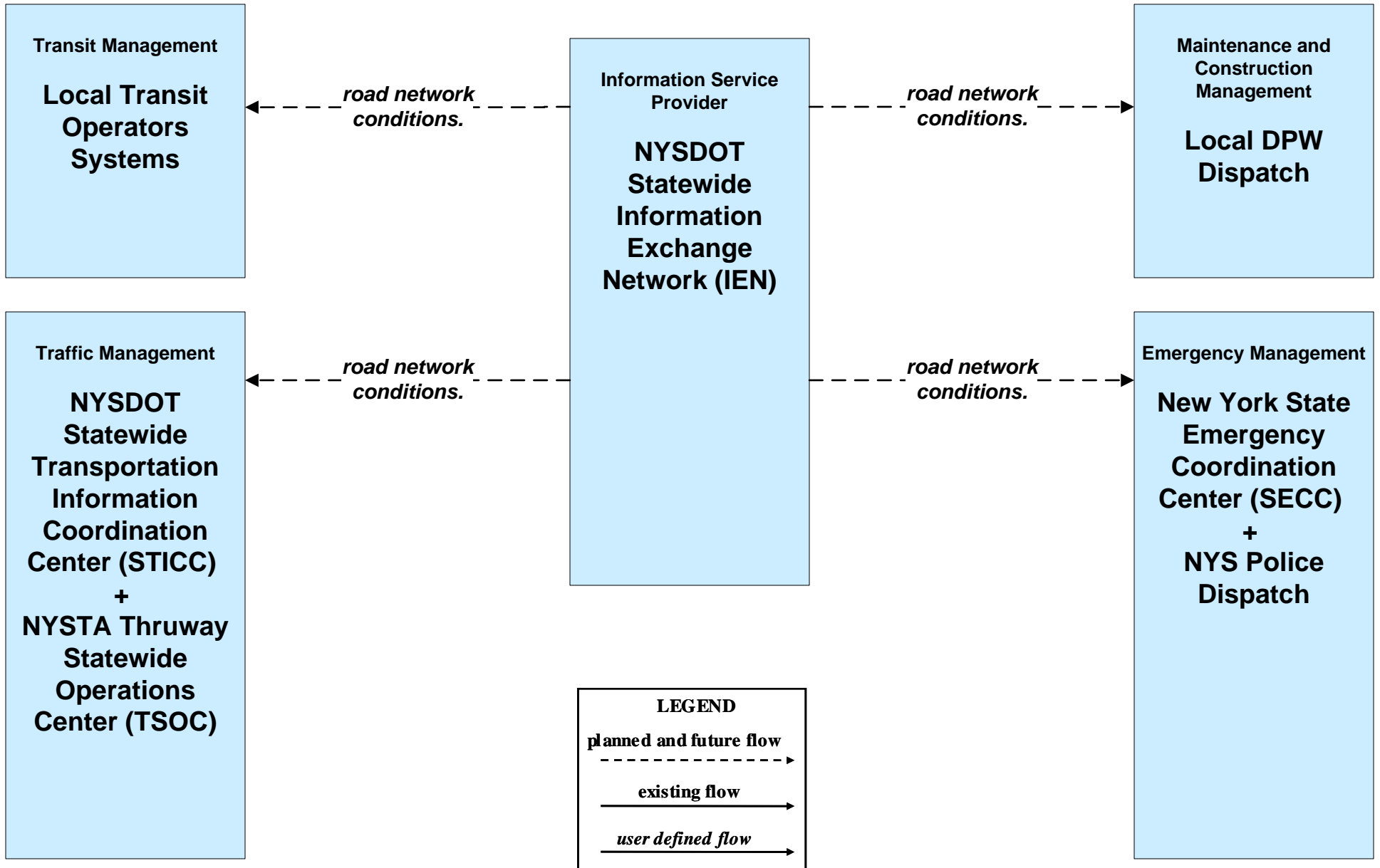

# ATMS06 - Traffic Information Dissemination NYSTA

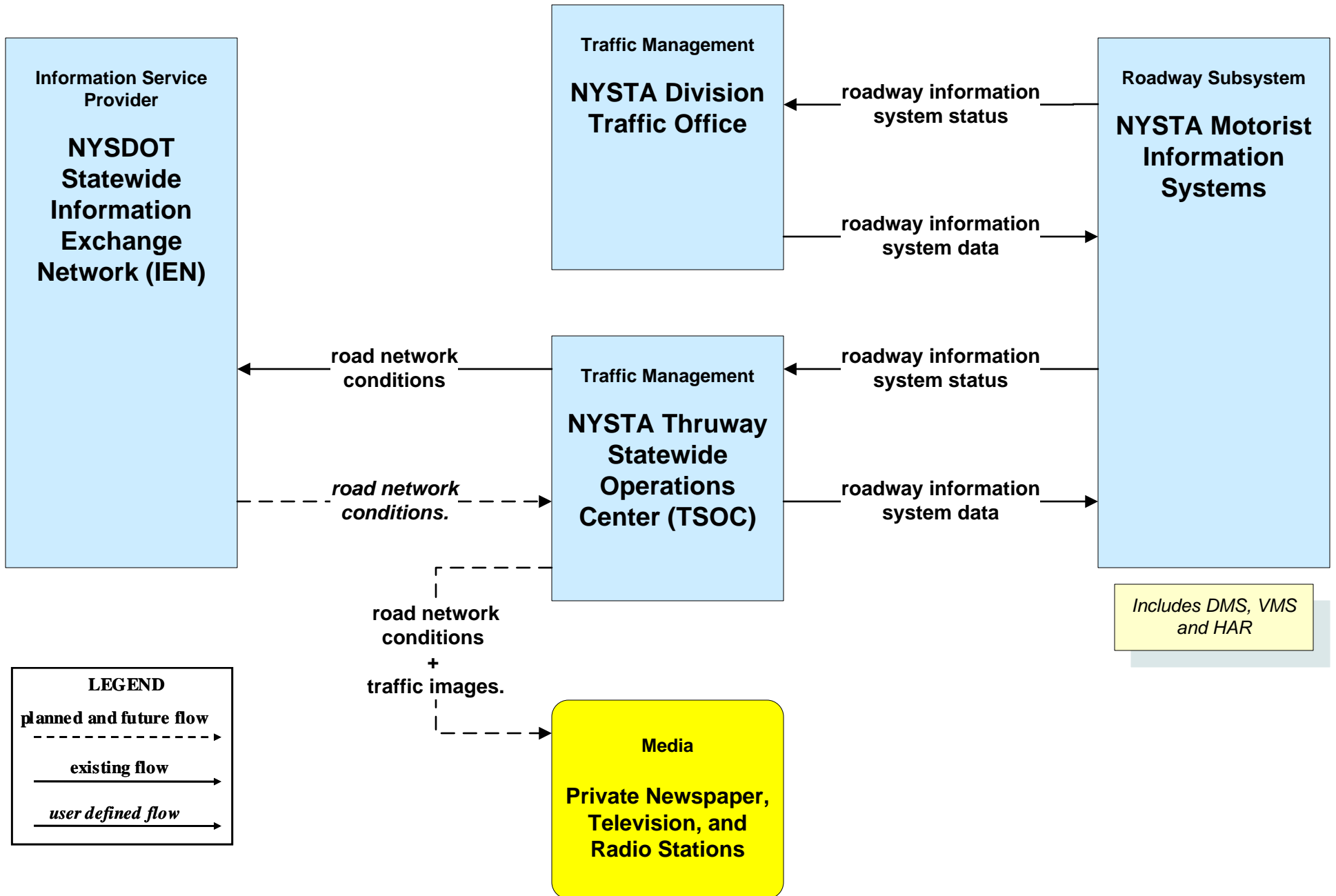

**ATMS07 - Regional Traffic Management  
 NYSDOT Statewide Information Exchange Network (IEN)**

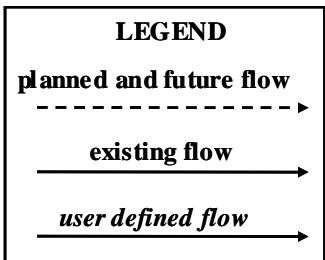
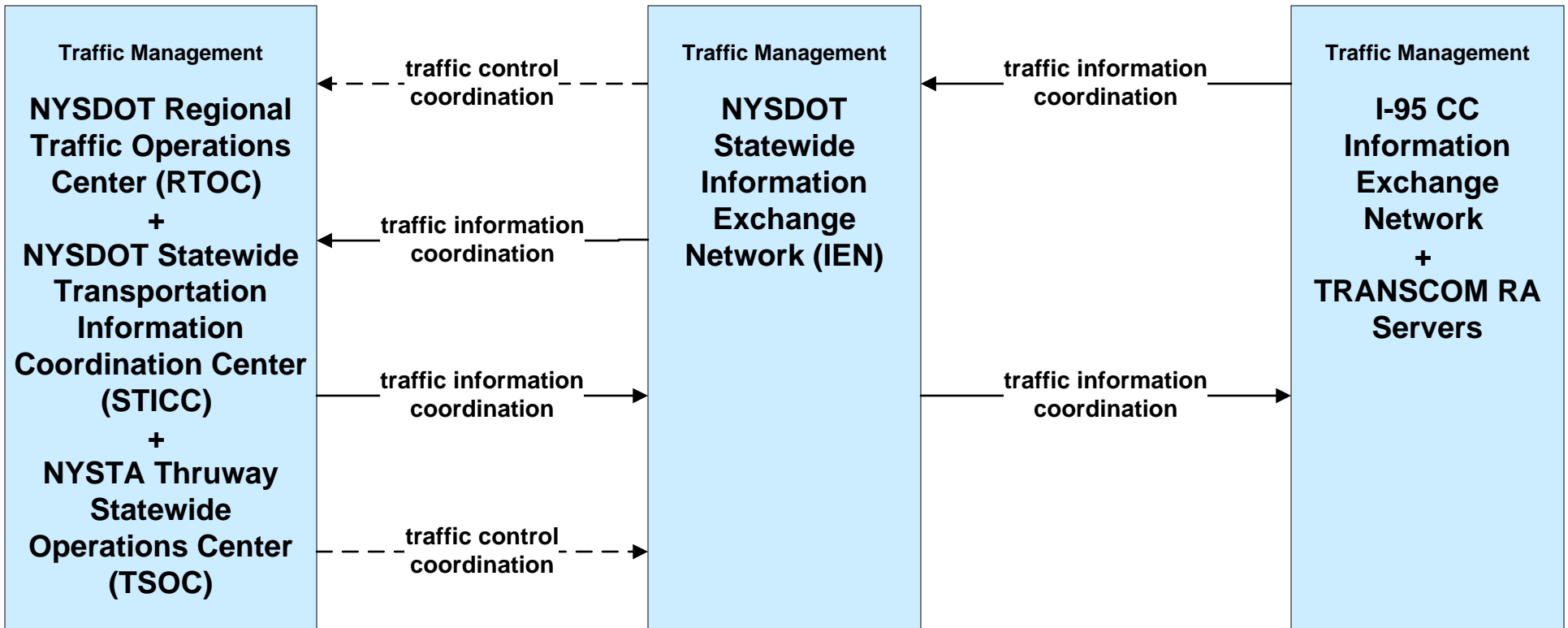

*Note: 511NY.ORG is a part of the IEN.*

**ATMS07 - Regional Traffic Management  
NYSDOT**

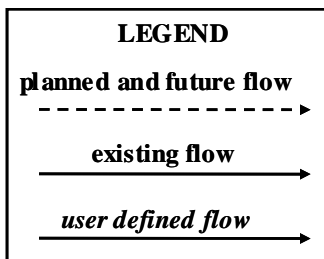
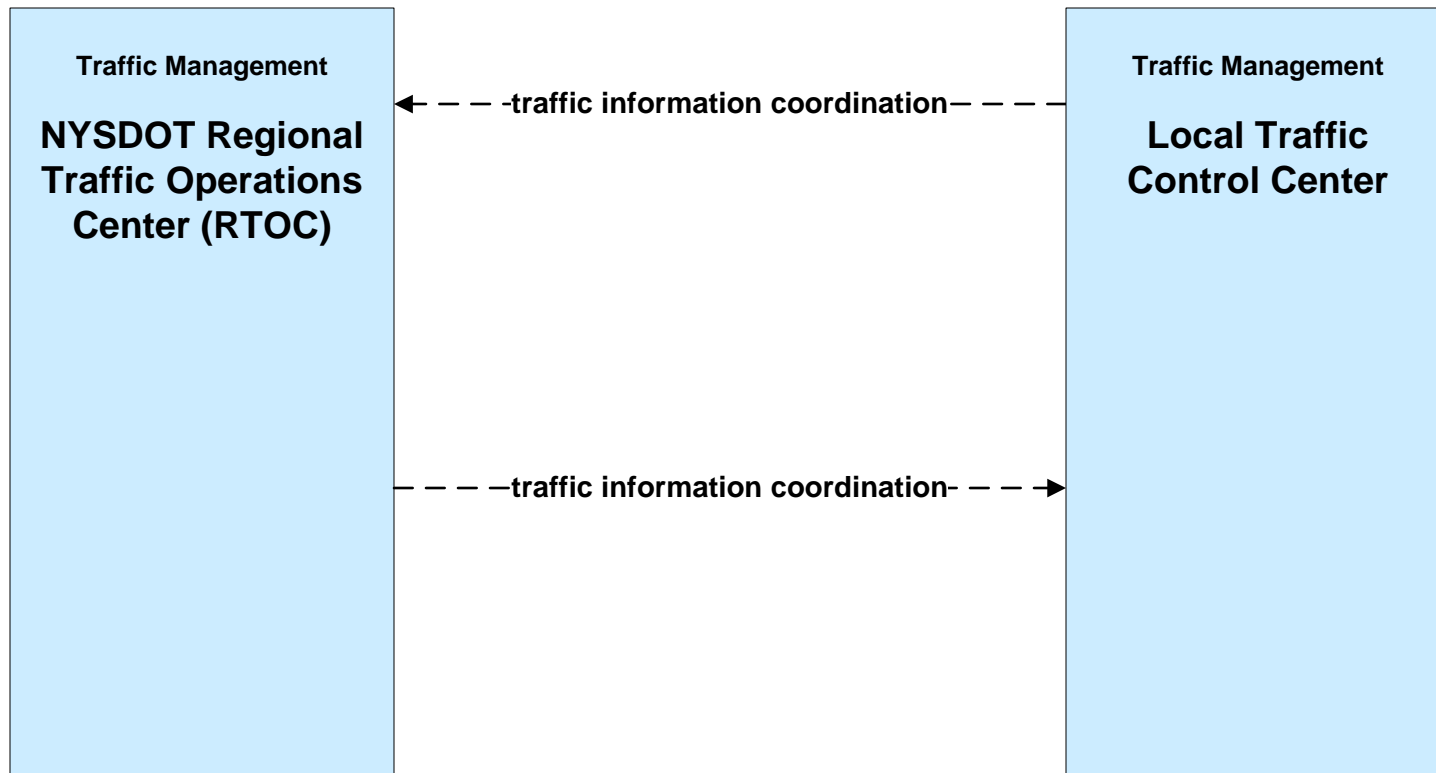

**ATMS07 - Regional Traffic Management  
 NYSDOT Statewide Video Exchange Network (VEN)**

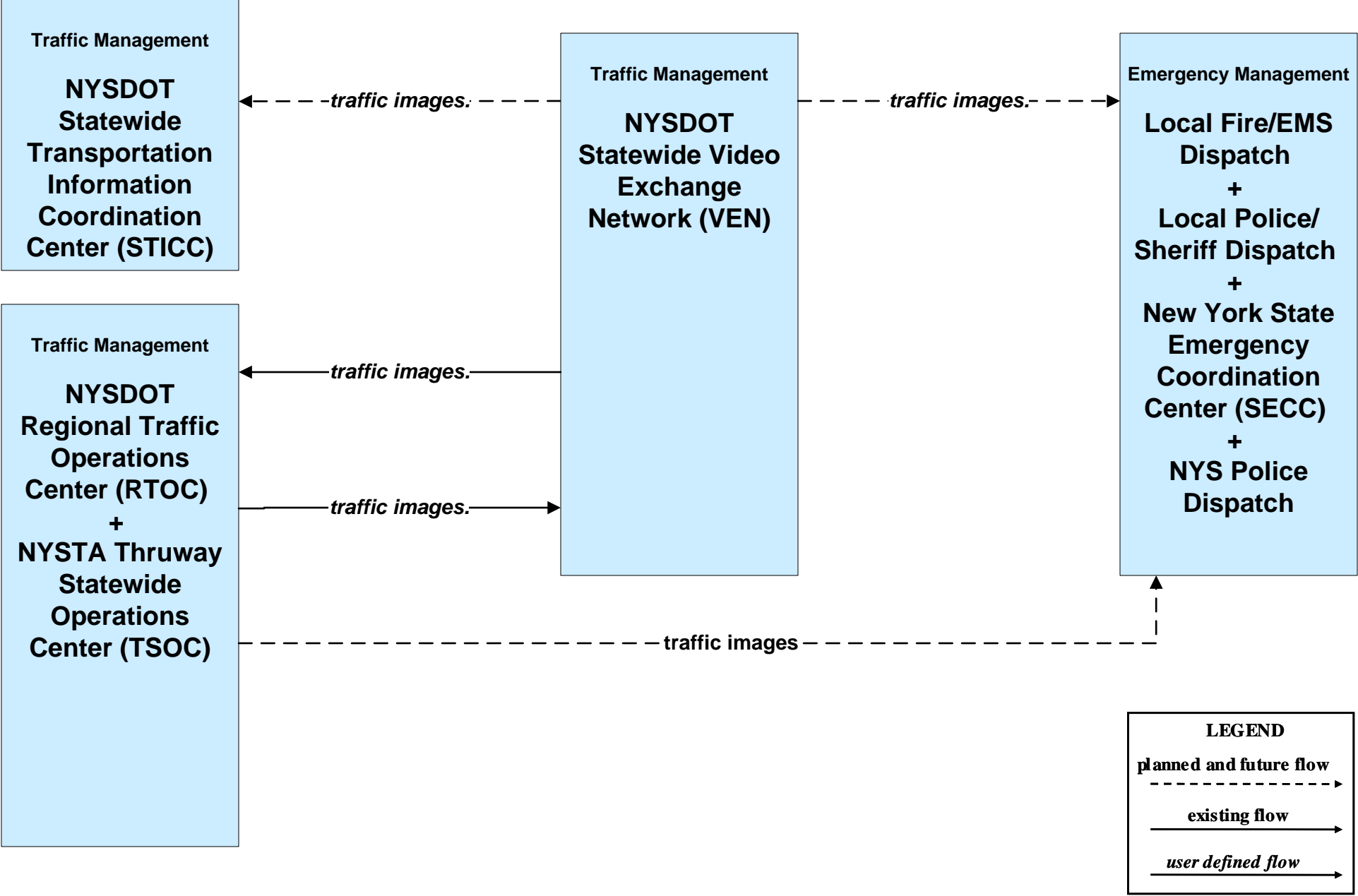

**ATMS07 - Regional Traffic Management  
NYSTA**

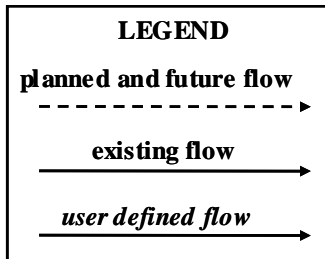
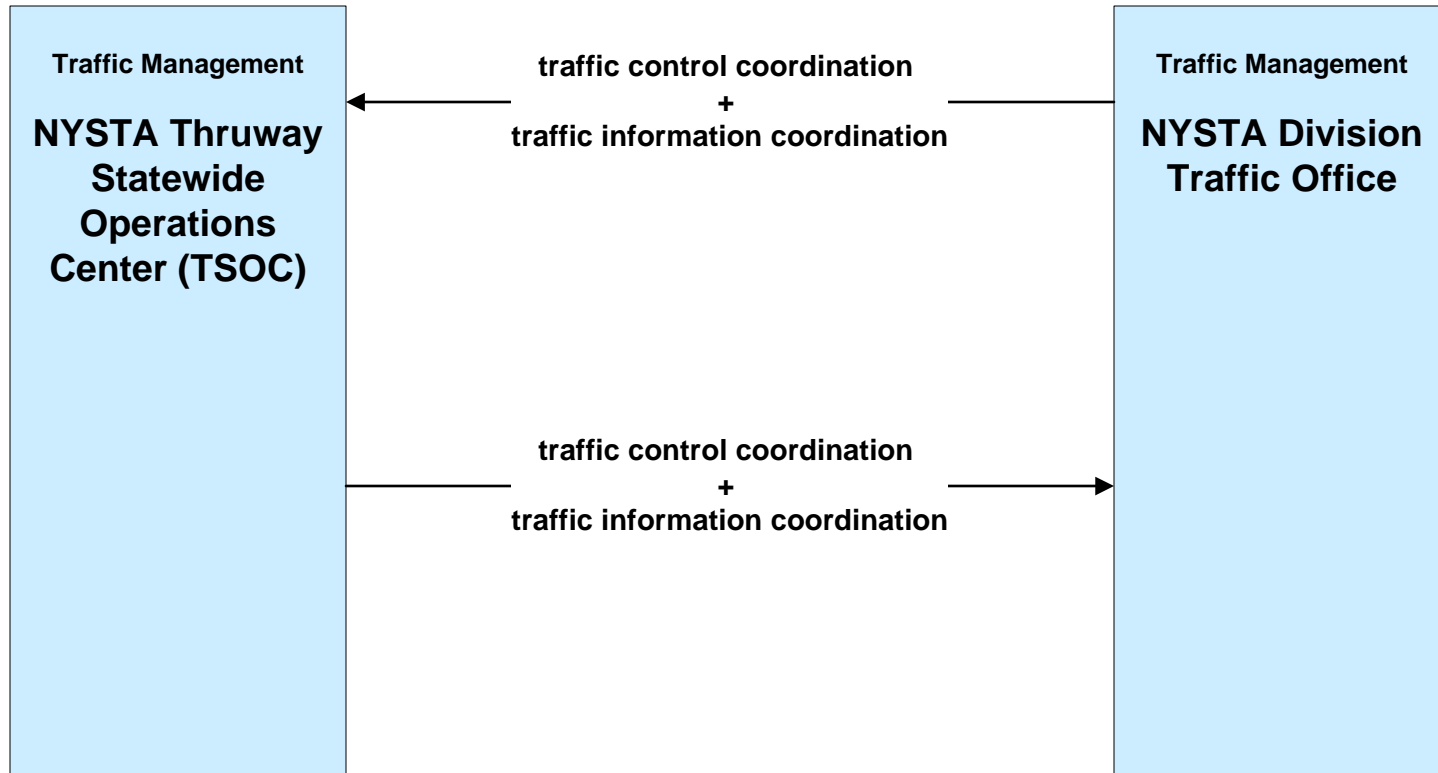



## **Incident Management Overview**

### ATMS08 Covers

<i>Emergency Management</i>	<i>Traffic Management</i>
<i>Emergency Management</i>	<i>Maintenance and Construction</i>
<i>Traffic Management</i>	<i>Maintenance and Construction</i>
<i>Maintenance and Construction</i>	<i>Maintenance and Construction</i>
<i>Event Plans and Weather</i>	<i>Traffic Management &amp; Emergency Management (see MCs for M&amp;C)</i>

### ATMS06, 03, 04, etc. Covers

<i>Traffic Management</i>	<i>Roadway</i>
---------------------------	----------------

### ATMS07 Covers

<i>Traffic Management</i>	<i>Traffic Management</i>
---------------------------	---------------------------

### EM1 Covers

<i>Emergency Management</i>	<i>Emergency Management</i>
-----------------------------	-----------------------------

### EM2 Covers

*Emergency Vehicle Preemption*

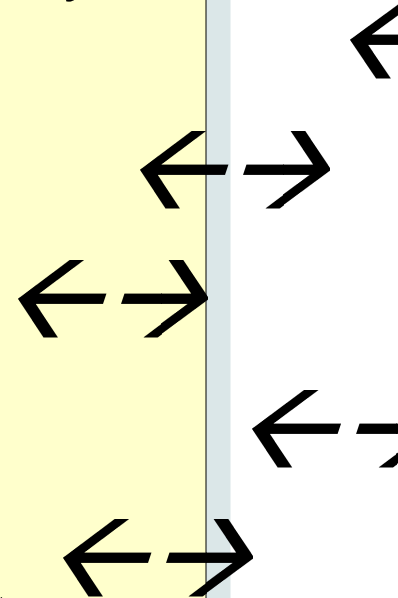

## **ATMS08 - Incident Management**

*Traffic Management*

*Emergency Management*



**ATMS08 - Incident Management  
 NYSDOT IEN (TM to EM)**

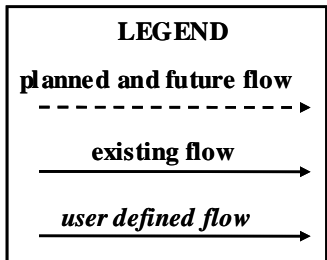
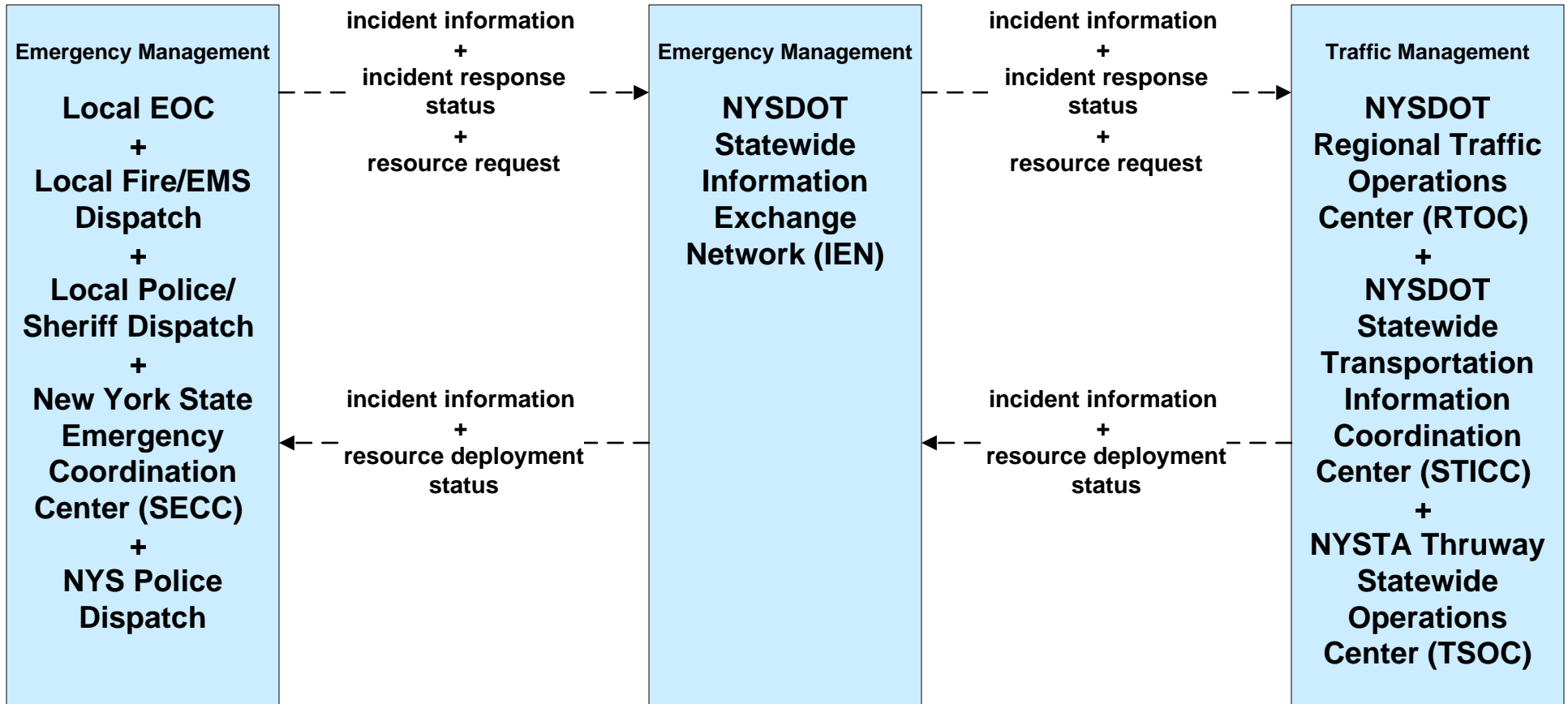

# ATMS08 - Incident Management NYSDOT RTOC (TM to EM)

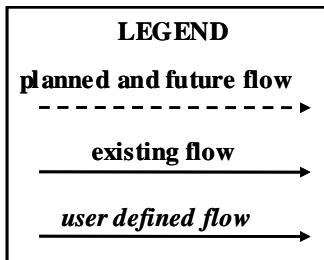
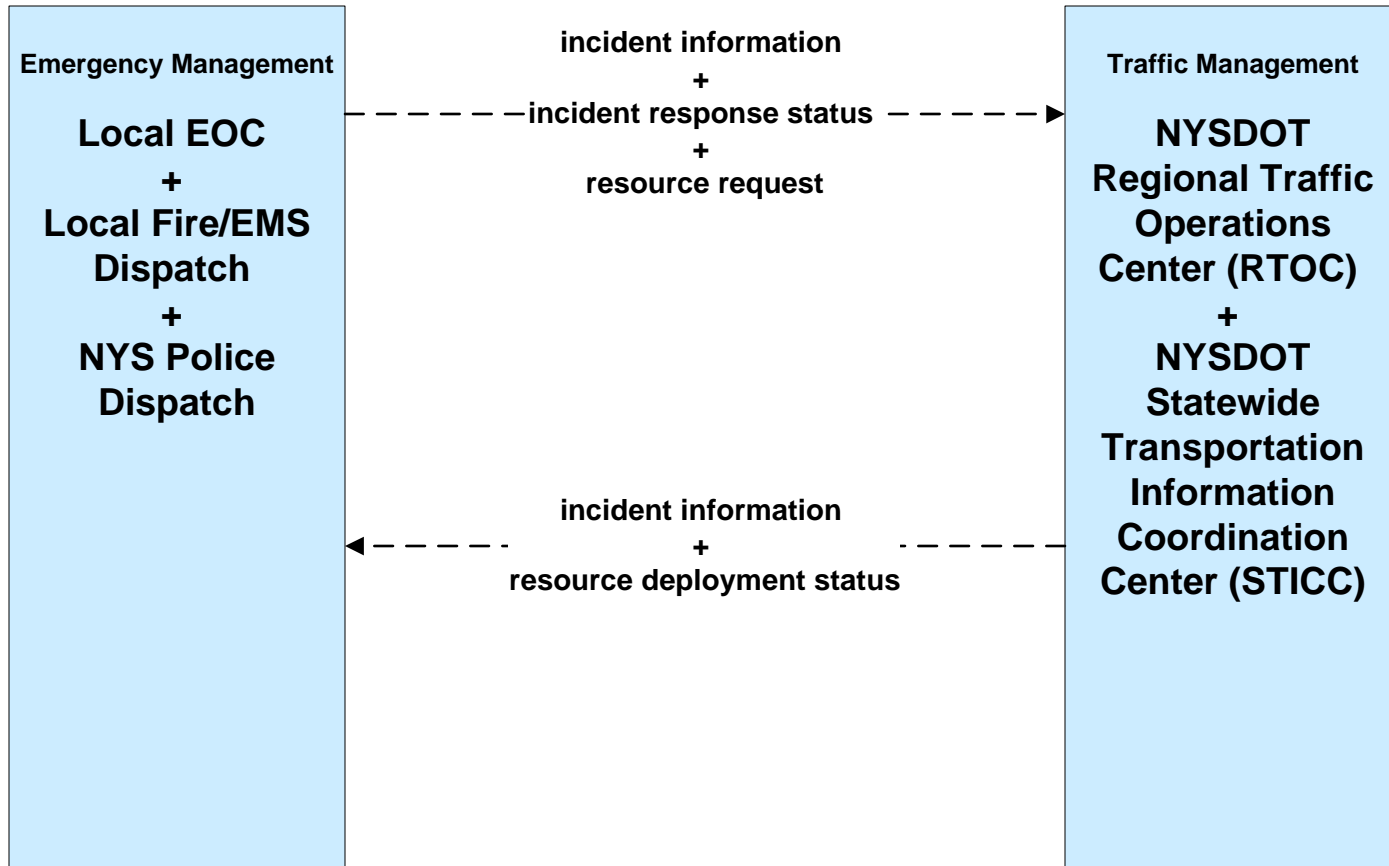

*This diagram shows those local public safety agencies that do not now or do not plan to connect to the NYSDOT IEN, and prefer to connect directly to the RTOC or the STICC, but a business case would have to be made.*

# ATMS08 - Incident Management NYSDOT (TM to EM)

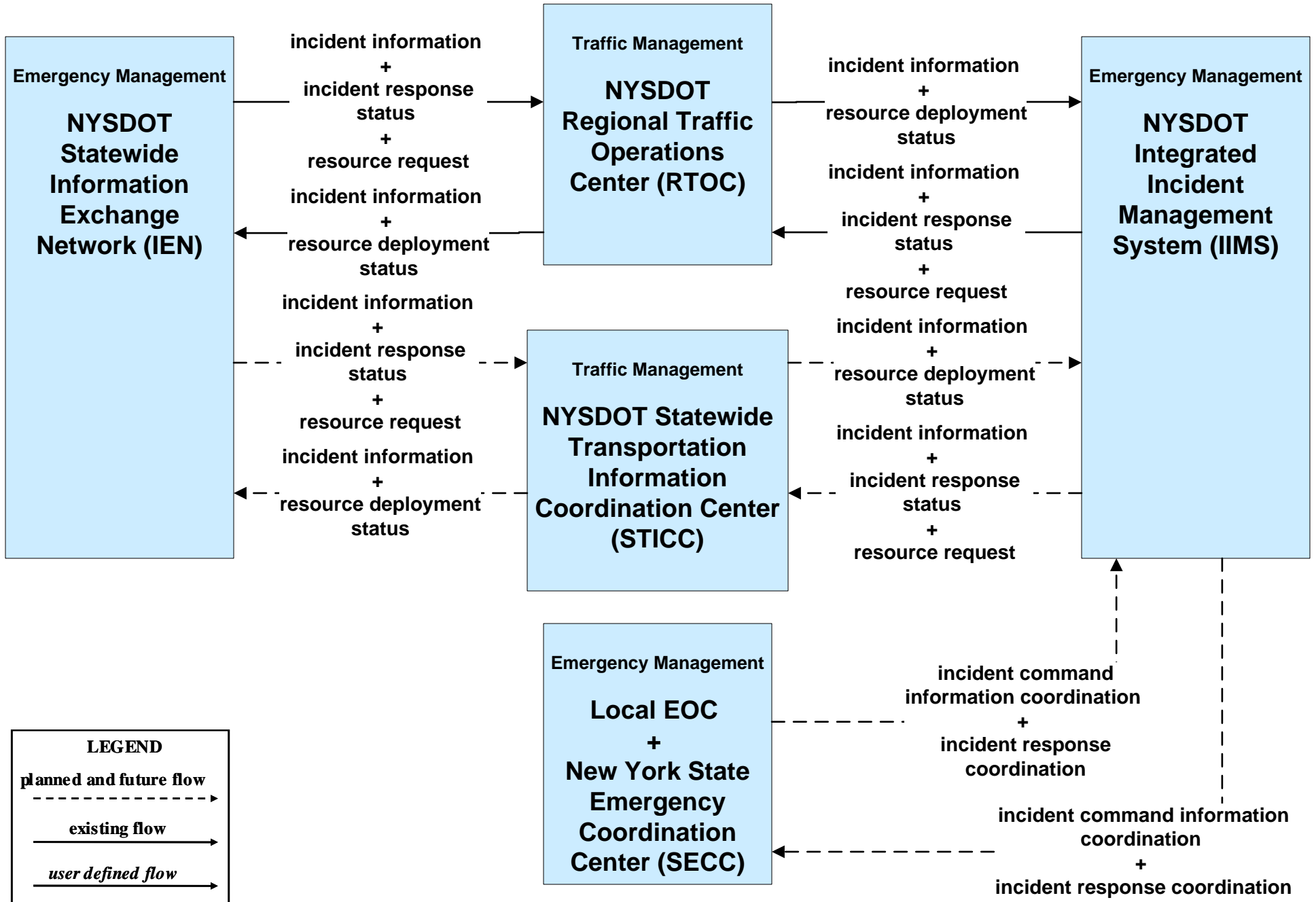

# ATMS08 - Incident Management NYSTA (TM to EM)

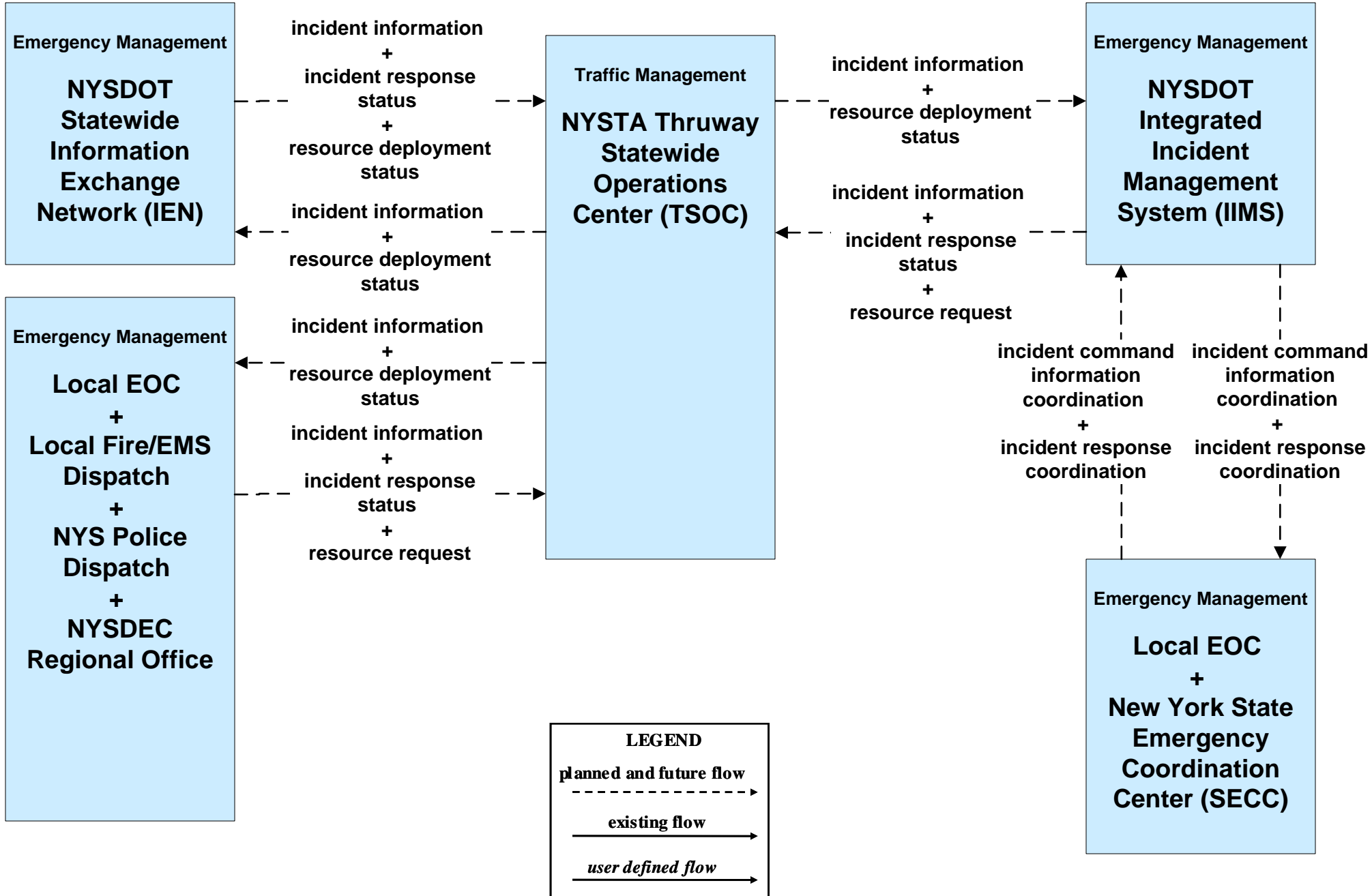

## **ATMS08 - Incident Management**

*Traffic Management*

*Maintenance and Construction Management*



**ATMS08 - Incident Management  
NYSDOT Regional TOCs (TM to MCM)**

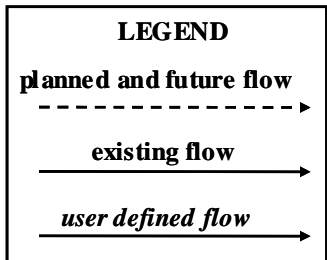
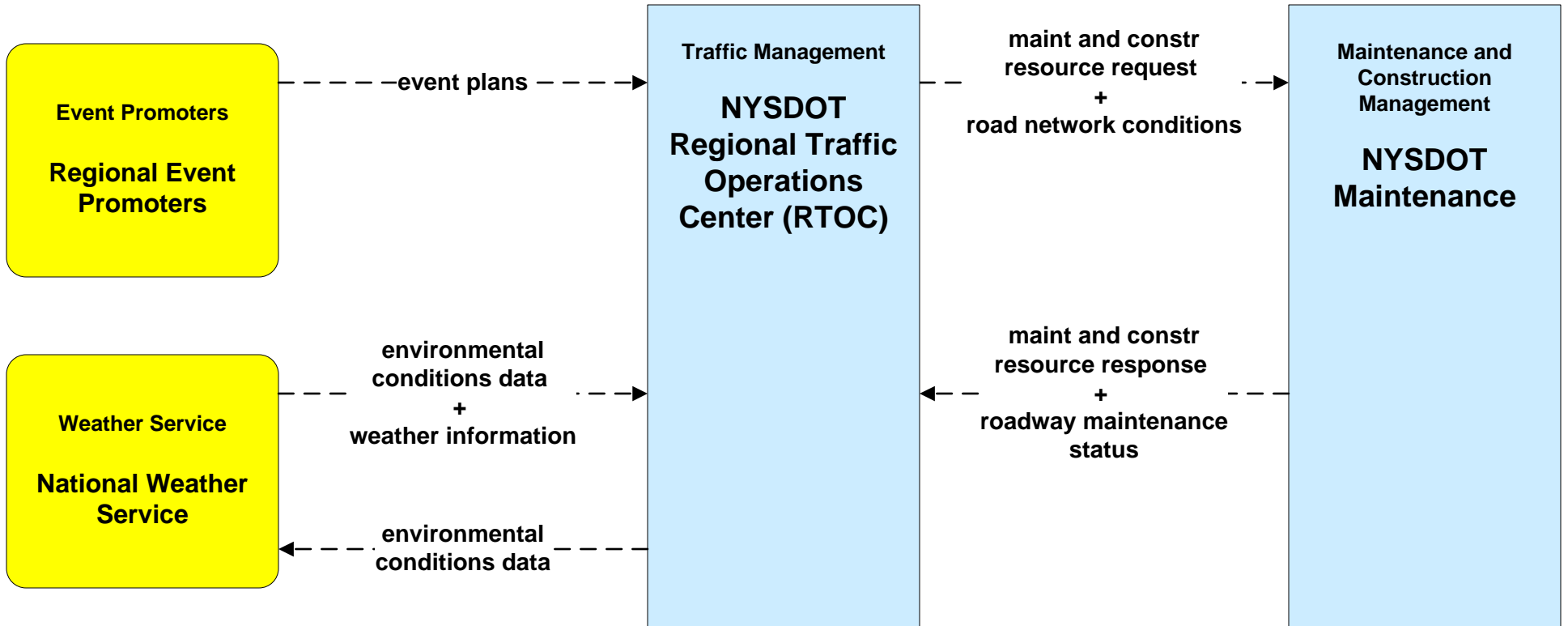



**ATMS08 - Incident Management  
NYSTA (TM to MCM)**

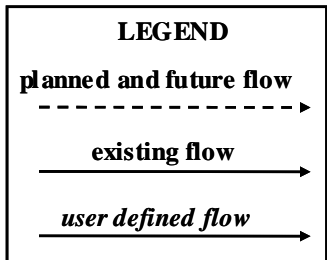
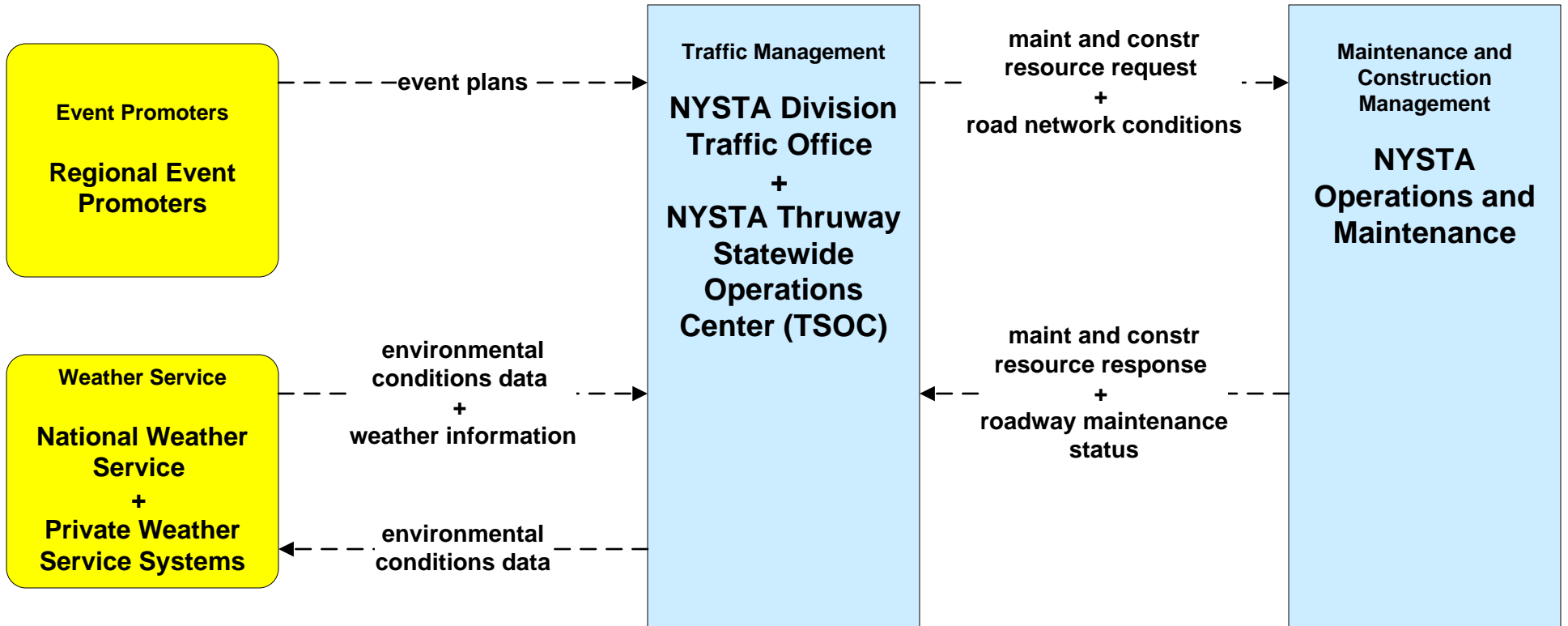

## **ATMS08 - Incident Management**

*Emergency Management*

*Maintenance and Construction Management*



**ATMS08 - Incident Management**  
**NYSDOT STICC / NYSDOT Regional TOCs (EM to MCM)**

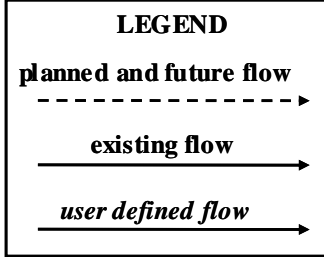
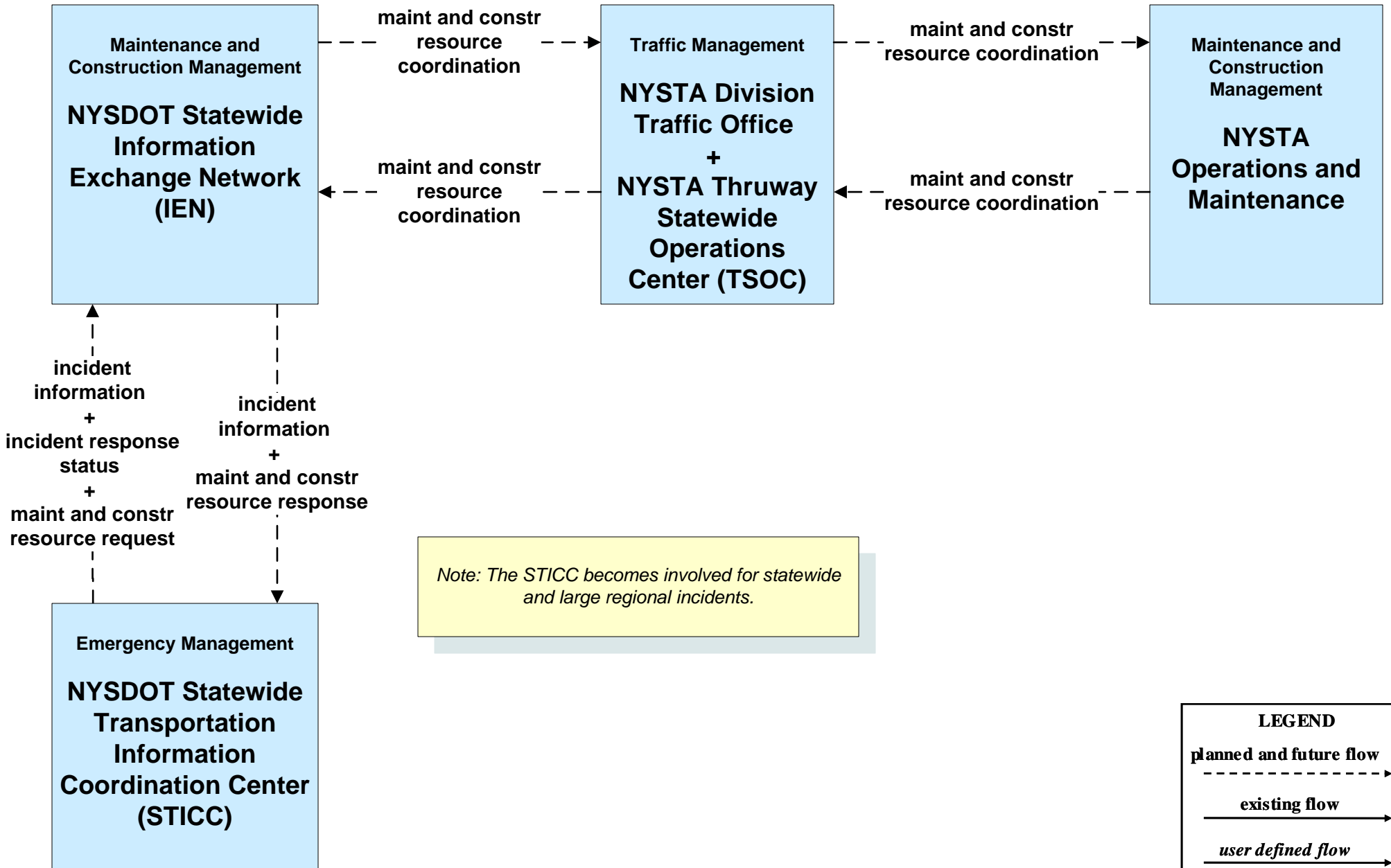

**ATMS08 - Incident Management  
NYSTA (EM to MCM)**

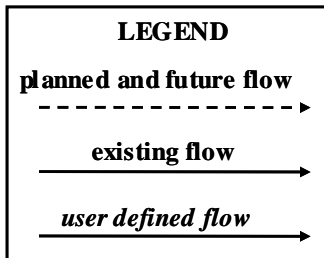
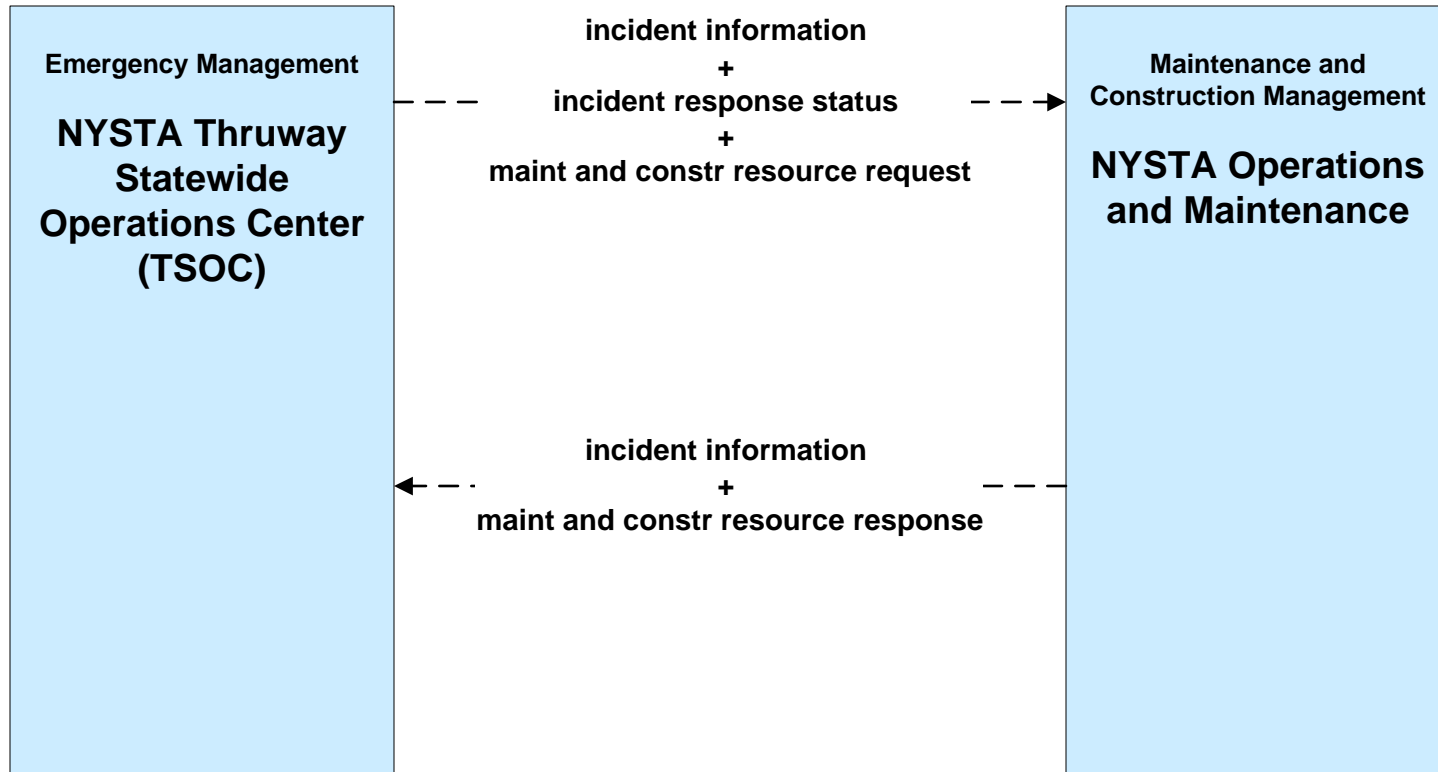

**ATMS08 - Incident Management**

*Emergency Management*

*Emergency Vehicles*



**ATMS08 - Incident Management**  
**NYSDOT Regional TOCs, NYSTA and IIMS**

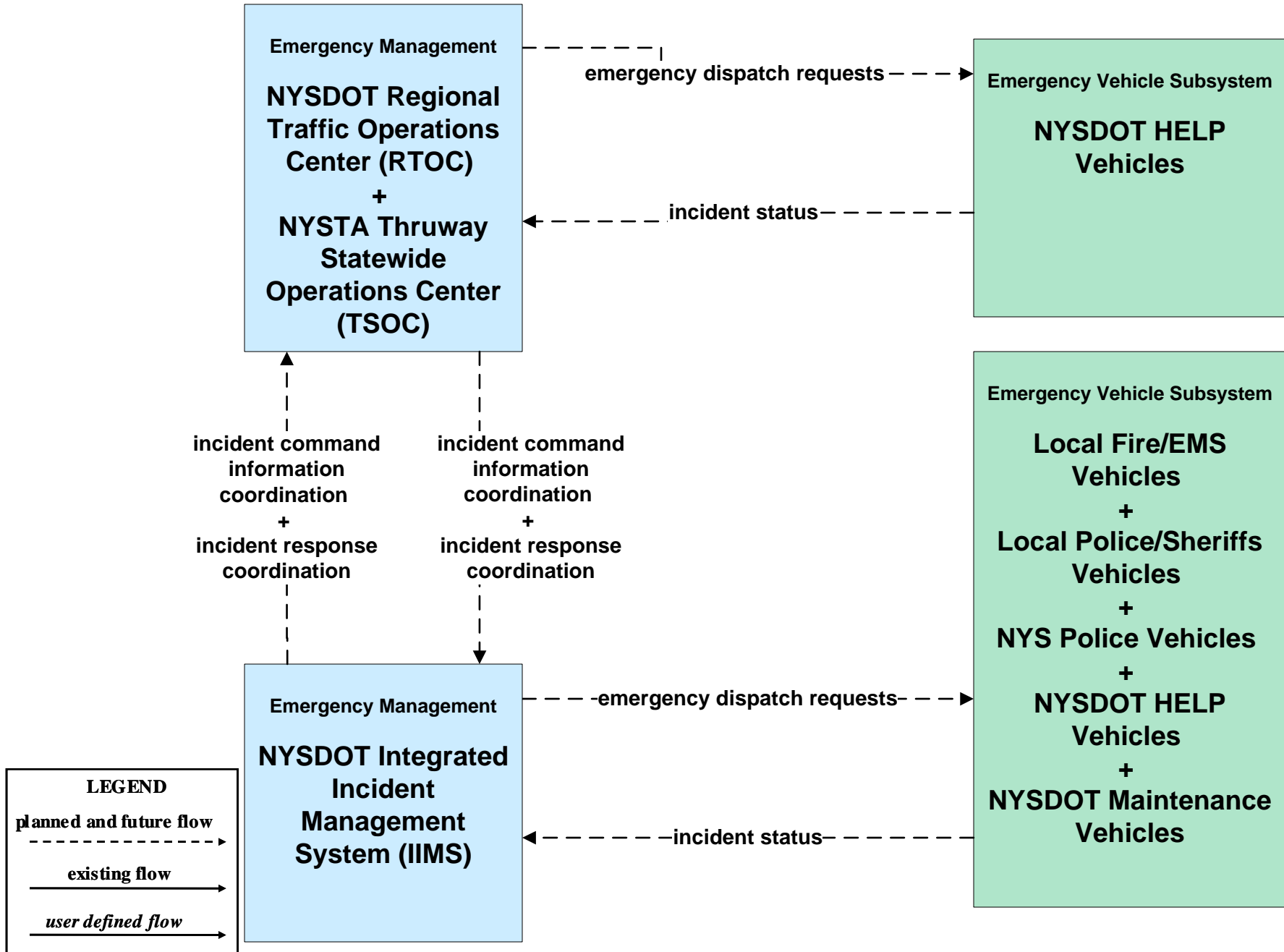

# ATMS10 - Electronic Toll Collection NYSTA Electronic Tolling

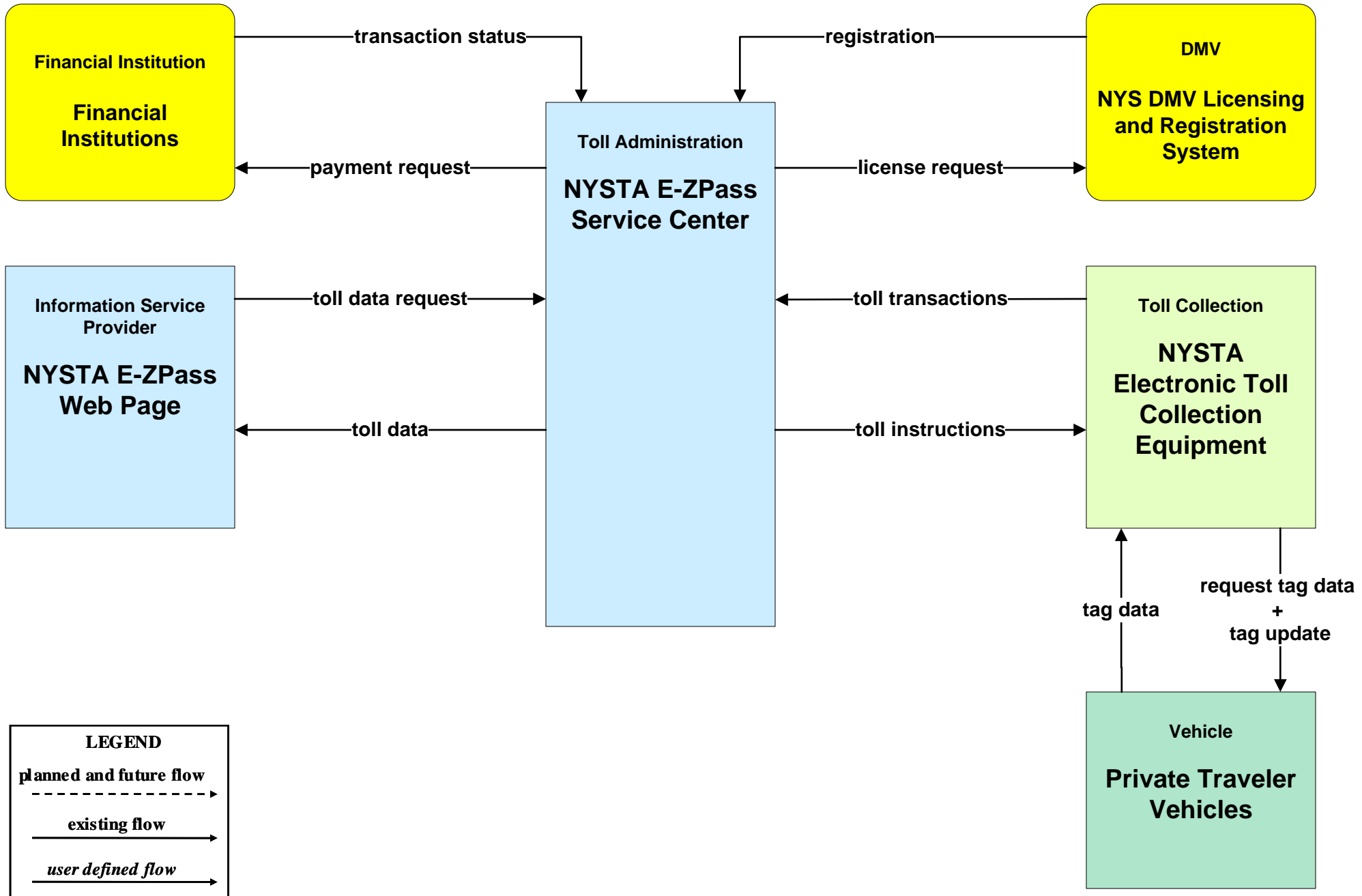

**ATMS11 - Emissions Monitoring and Management  
NYSDOT Main Office**

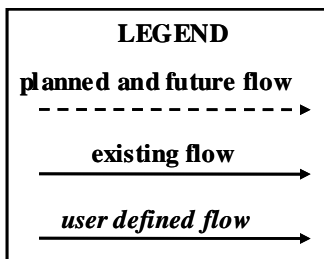
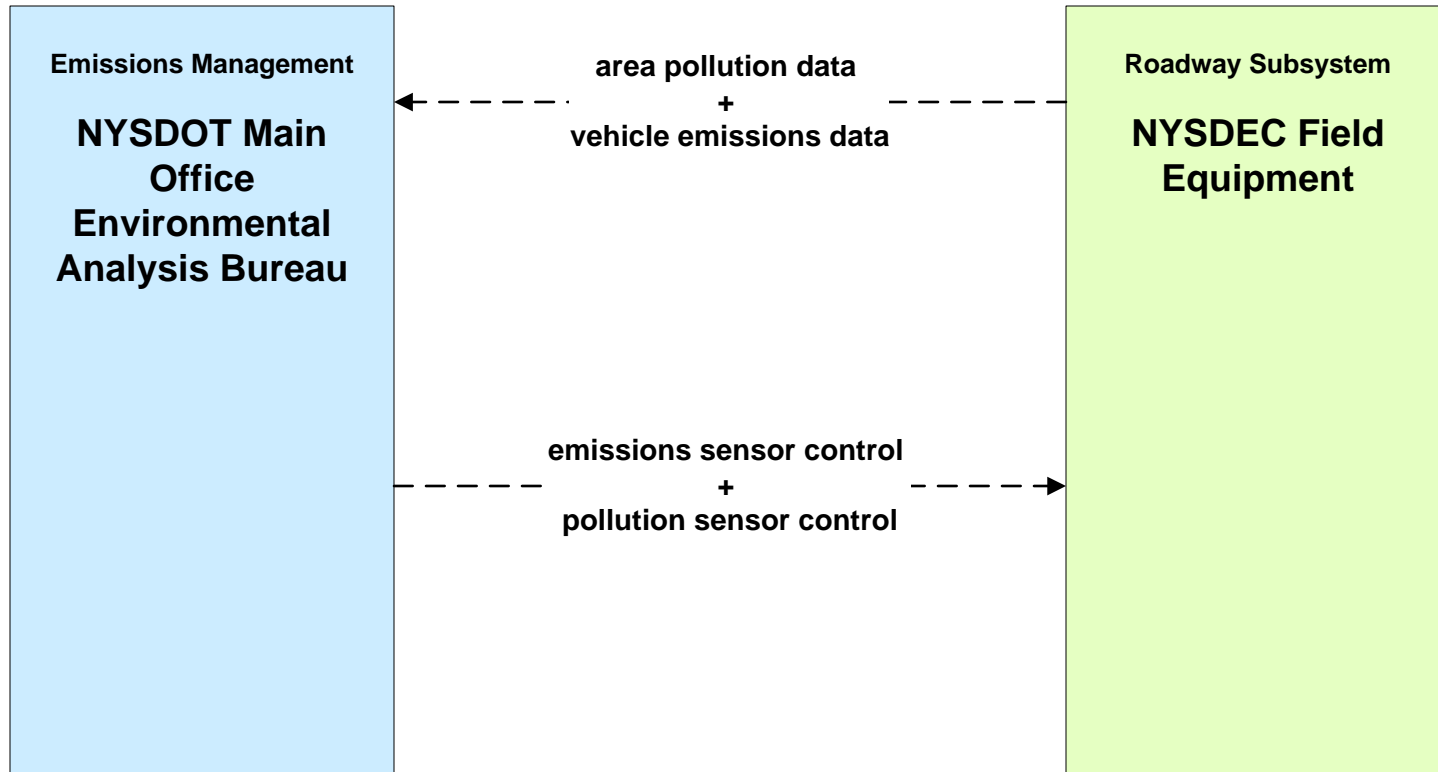



# ATMS13 - Standard Railroad Crossing NYSDOT Traffic Signals

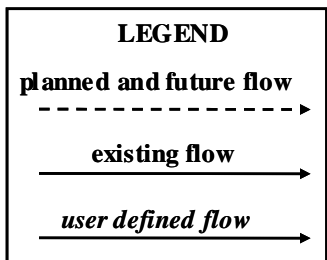
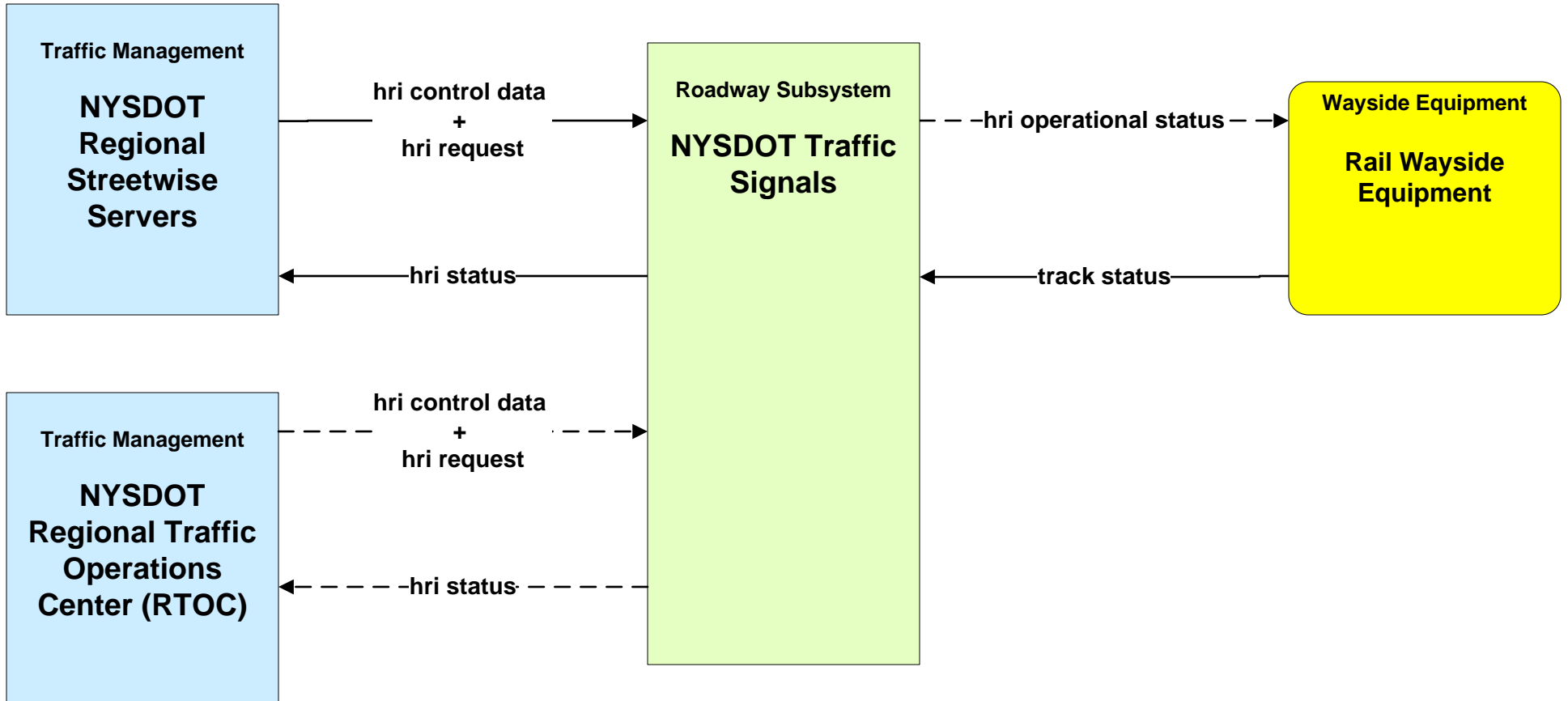

**ATMS18 - Reversible Lane Management  
NYSTA**

