

AD1 - ITS Data Mart Winooski Data Repository

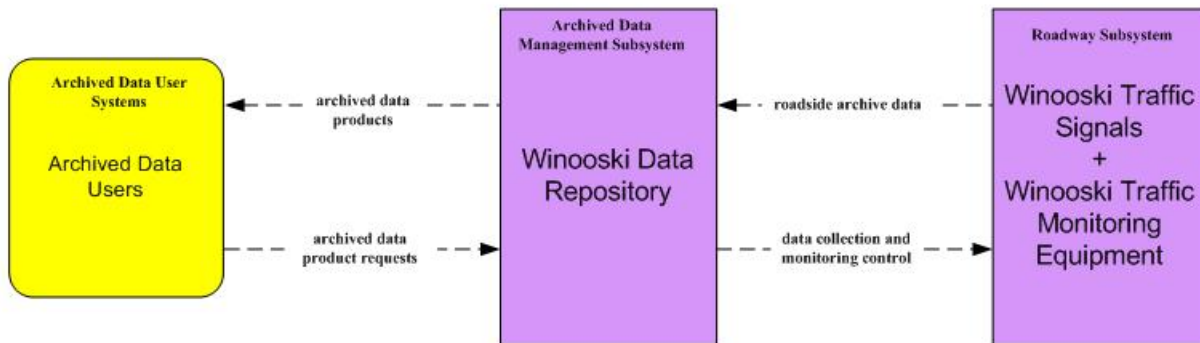

LEGEND

planned and future flow

existing flow

user defined flow

AD2 - ITS Data Warehouse
CCMPO Data Warehouse

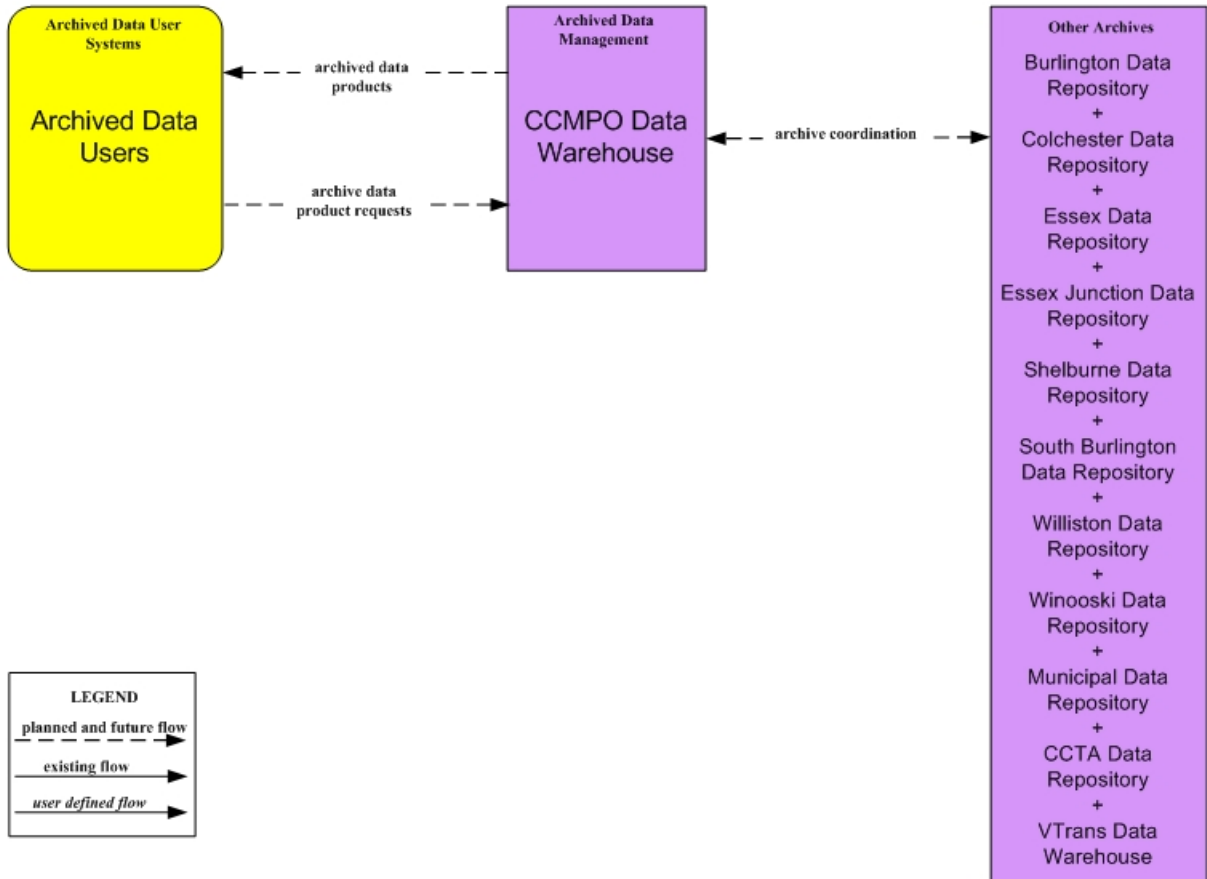

APTS7 – Multimodal Coordination
CCTA Fixed Route Dispatch – Chittenden Regional TOC and VTrans State TOC

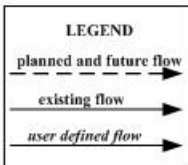
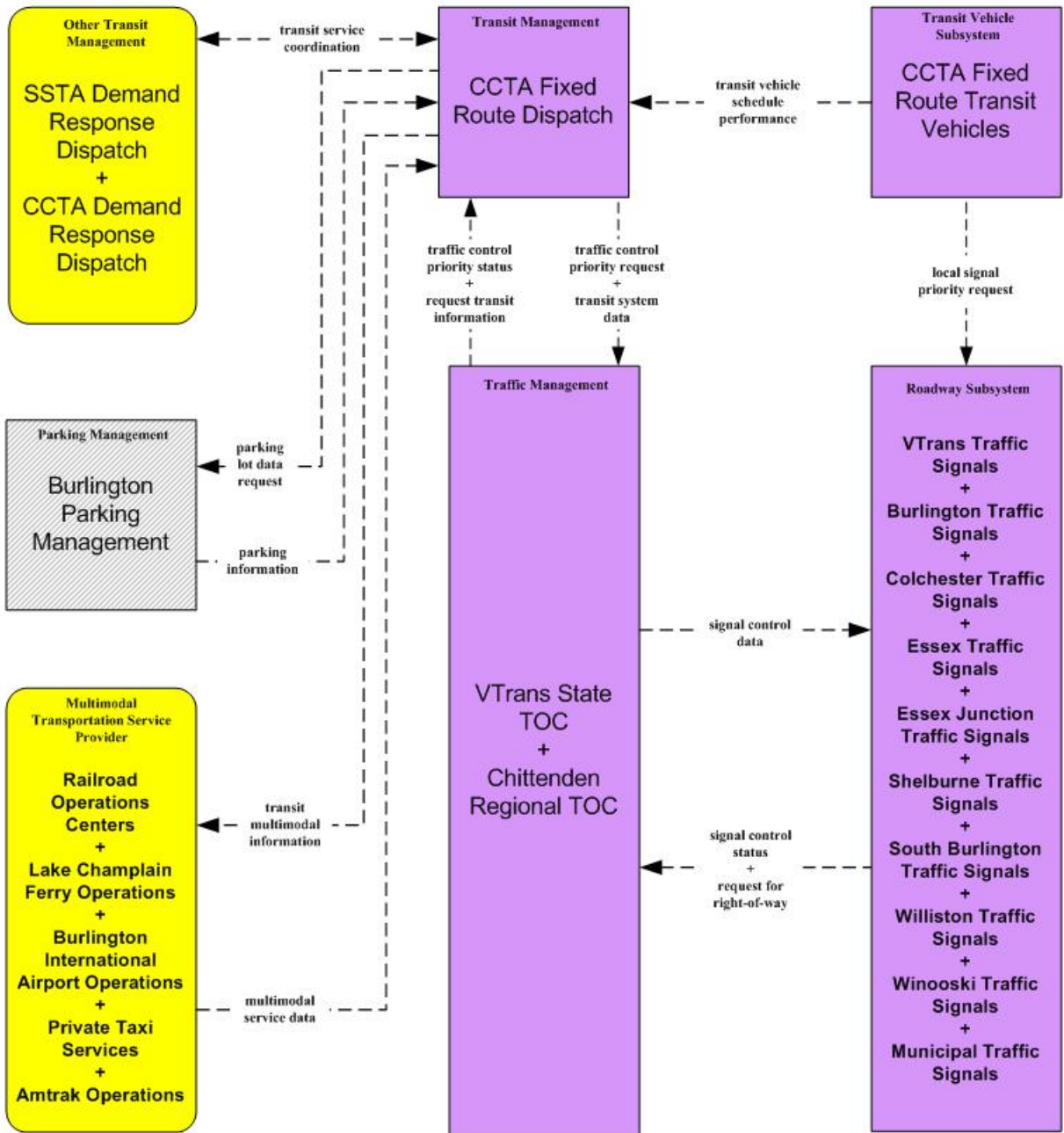

This market package instance is pending creation of the Chittenden Regional TOC. See the other APTS7 instance for details if it is not.

APTS7 – Multimodal Coordination CCTA Fixed Route Dispatch

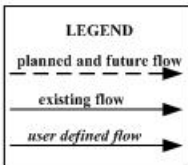
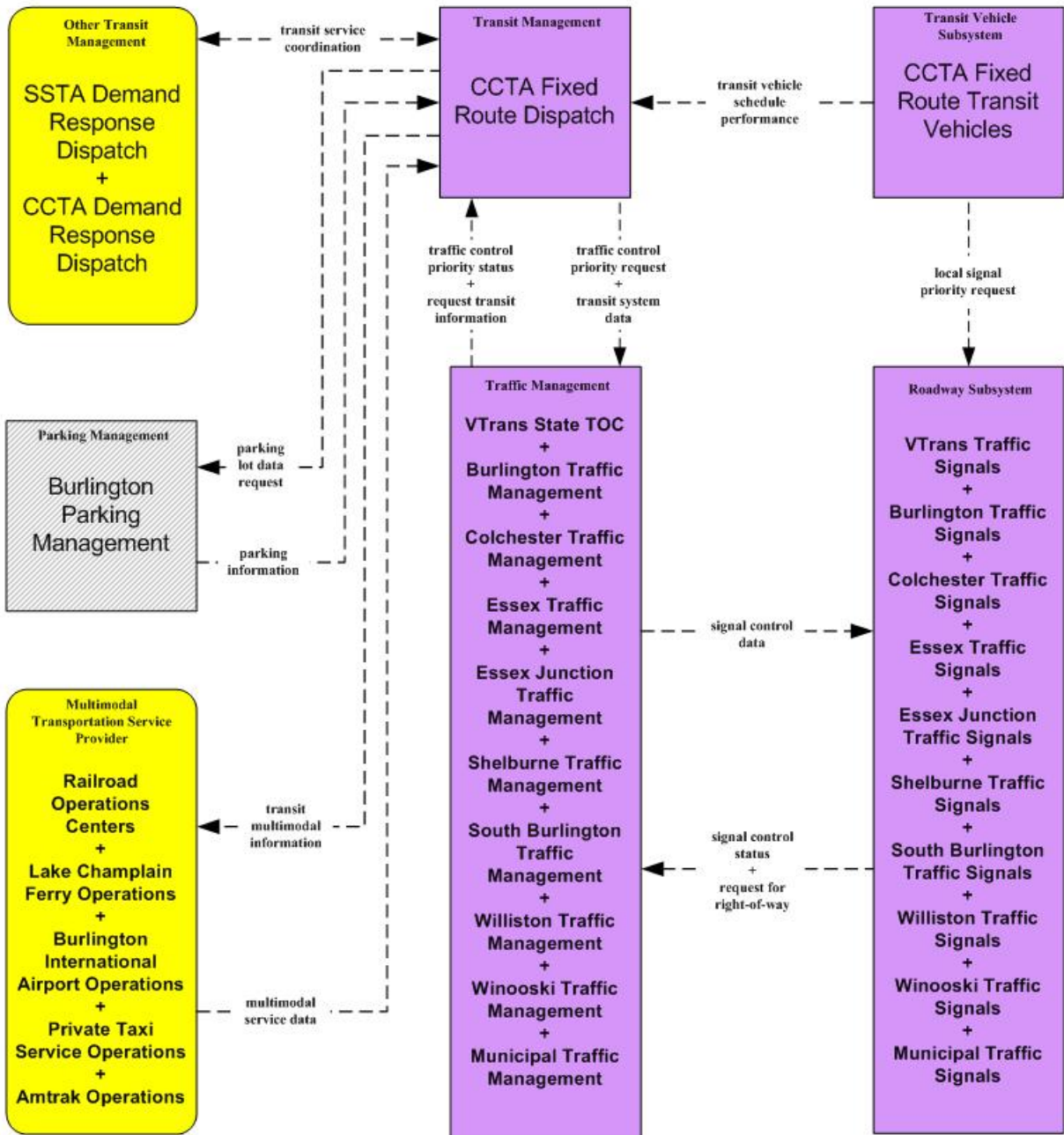

This market package instance is valid if the Chittenden Regional TOC is not created. See the APTS7 – Chittenden Regional TOC instance for details if it is.

ATIS1 - Broadcast Traveler Information CARS Information System

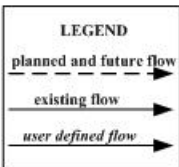
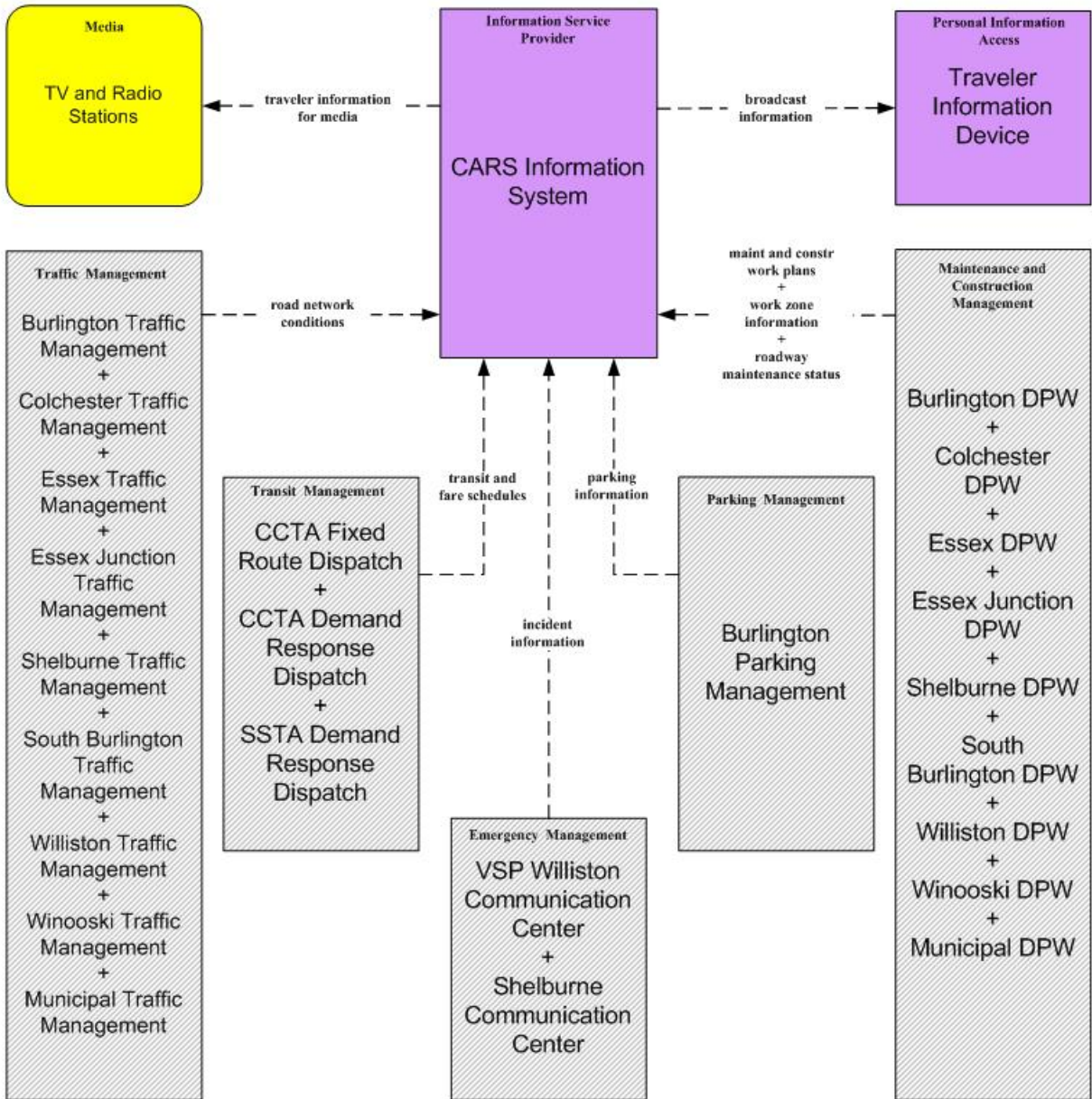

This market package instance is valid if the Chittenden Regional TOC is not created. See the ATIS1 – CARS – Chittenden Regional TOC instance for details if it is.

**ATIS1 - Broadcast Traveler Information
CARS Information System – Chittenden Regional TOC**

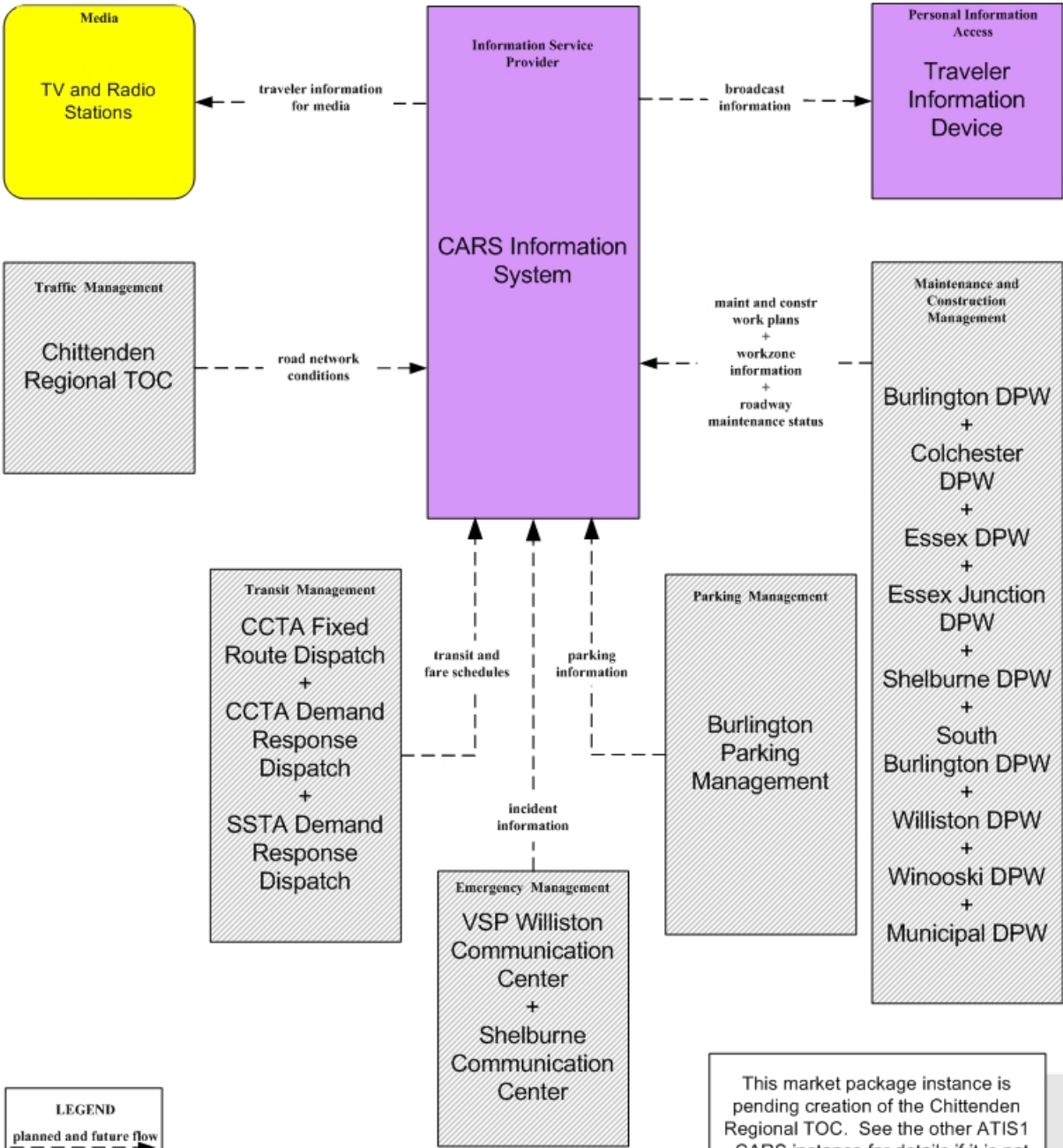

LEGEND

- planned and future flow
- existing flow
- user defined flow

This market package instance is pending creation of the Chittenden Regional TOC. See the other ATIS1 – CARS instance for details if it is not.

ATIS1 - Broadcast Traveler Information Winooski Website

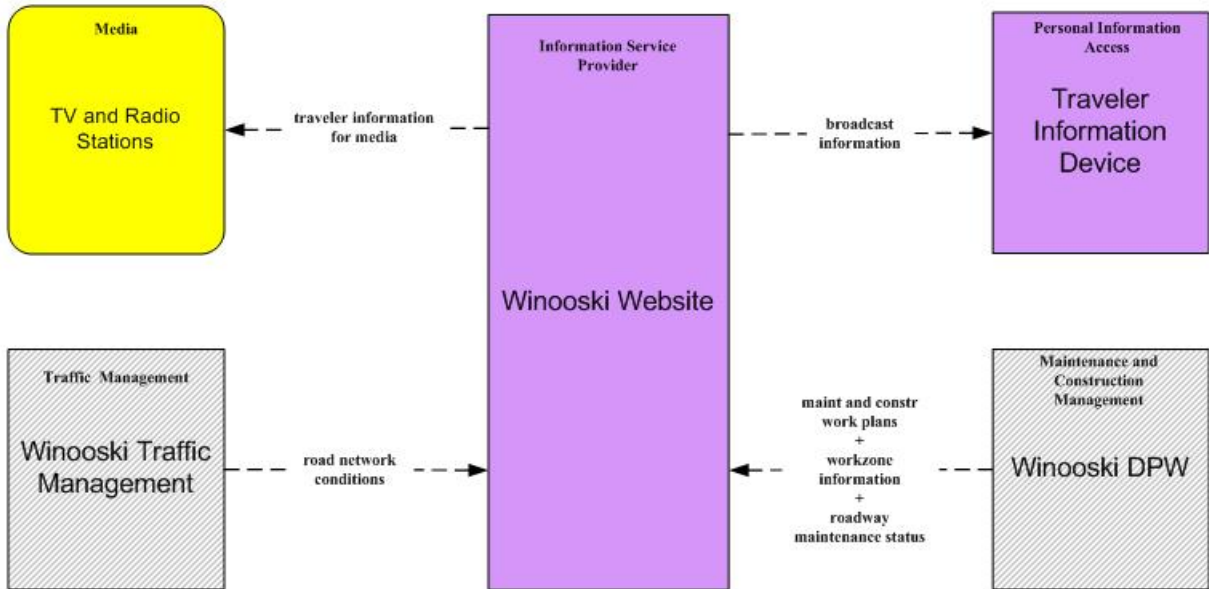

LEGEND

planned and future flow →

existing flow →

user defined flow →

ATMS01 - Network Surveillance Winooski Traffic Management

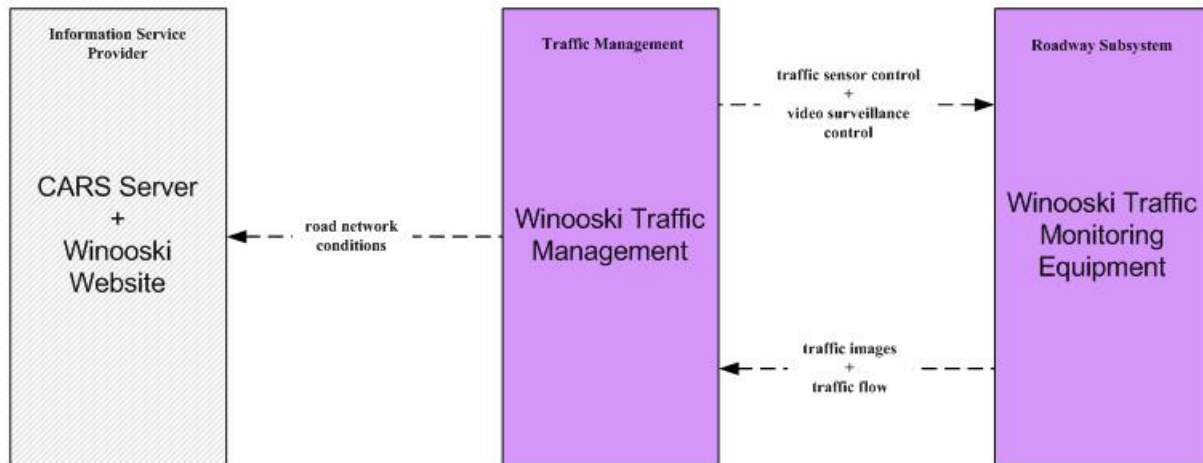

LEGEND

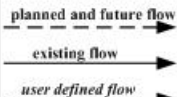

ATMS03 - Surface Street Control
Winooski Traffic Management

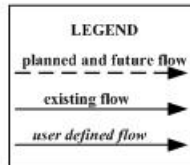
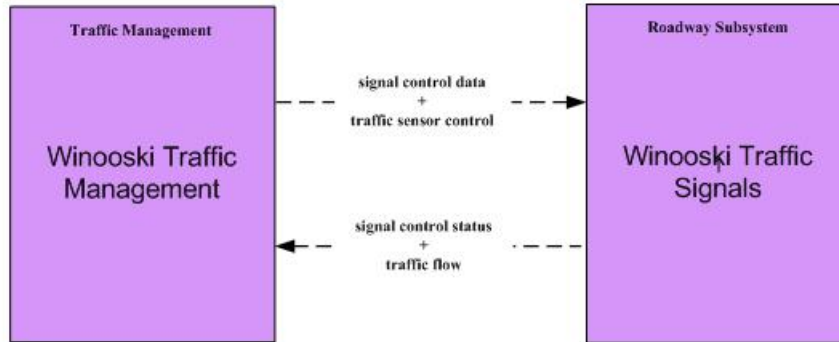

**ATMS06 – Traffic Information Dissemination
Chittenden Regional TOC (Future)**

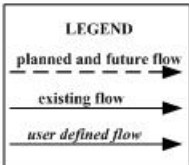
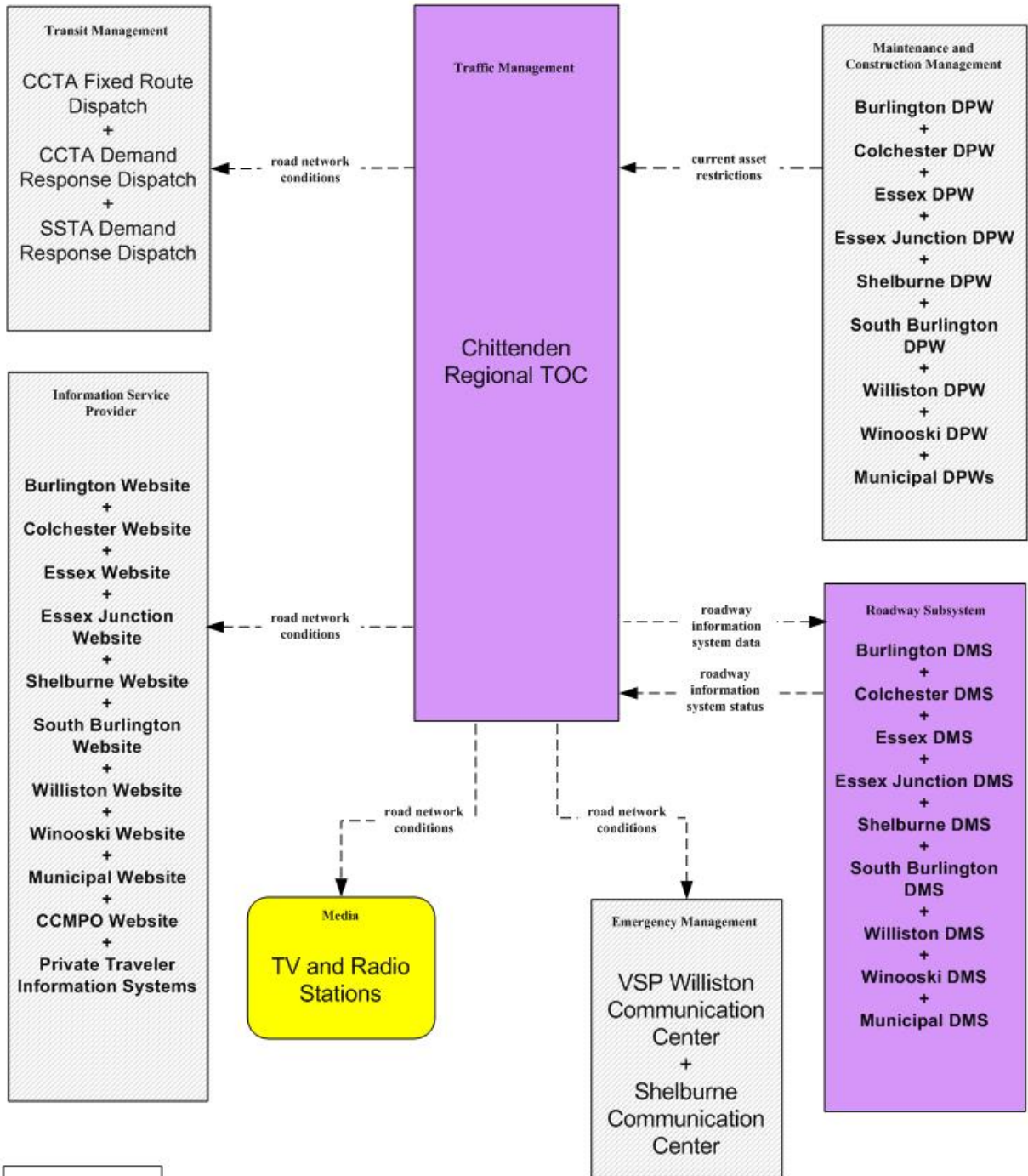

ATMS06 – Traffic Information Dissemination Winooski Traffic Management

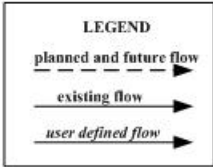
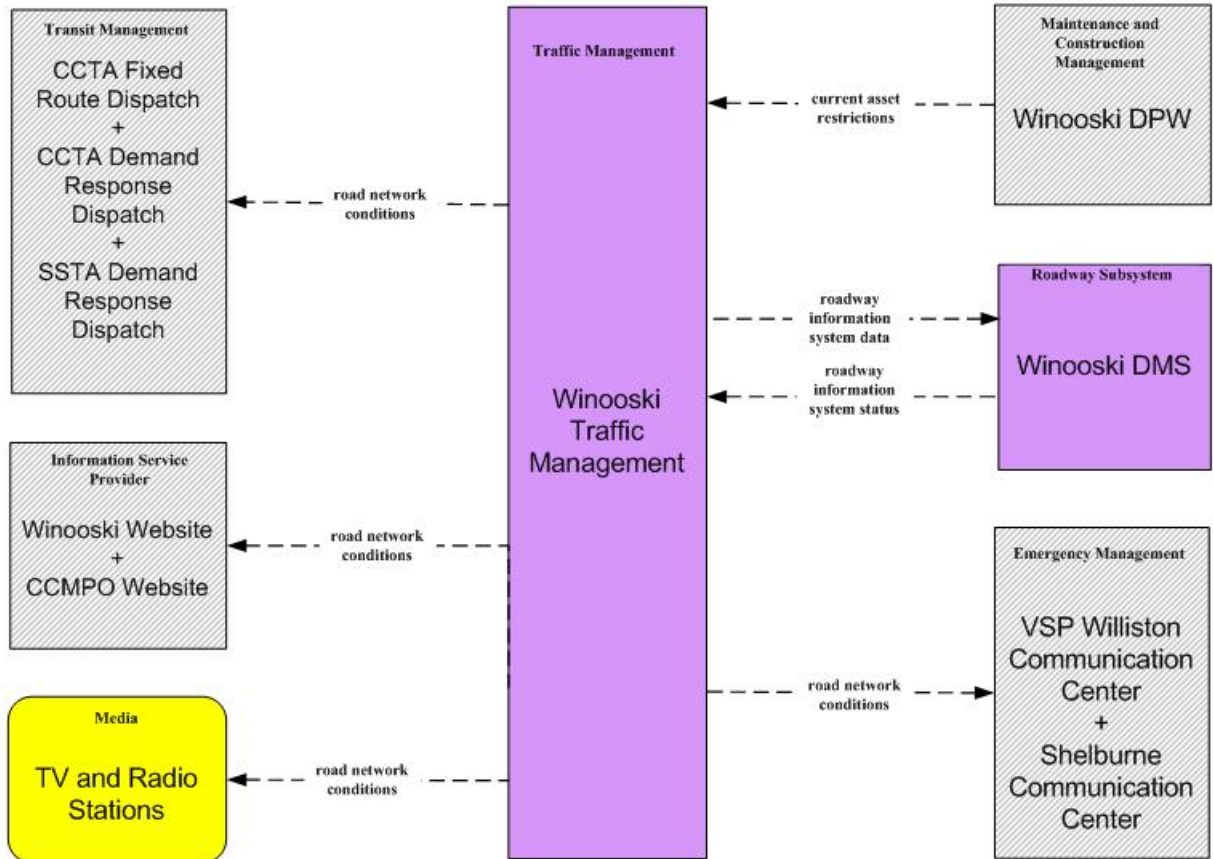

ATMS07 – Regional Traffic Control
Chittenden Regional TOC

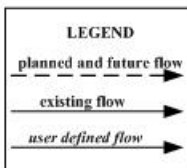
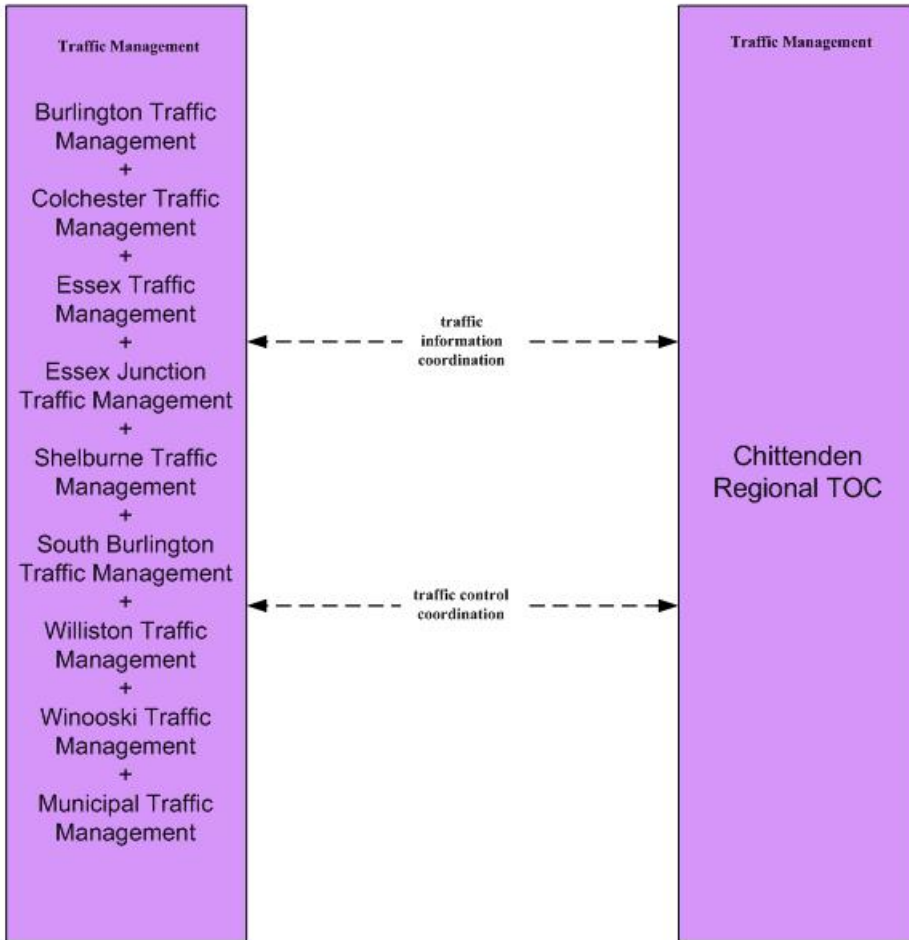

ATMS08 – Incident Management
Chittenden Regional TOC

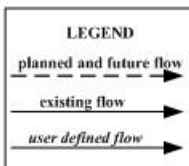
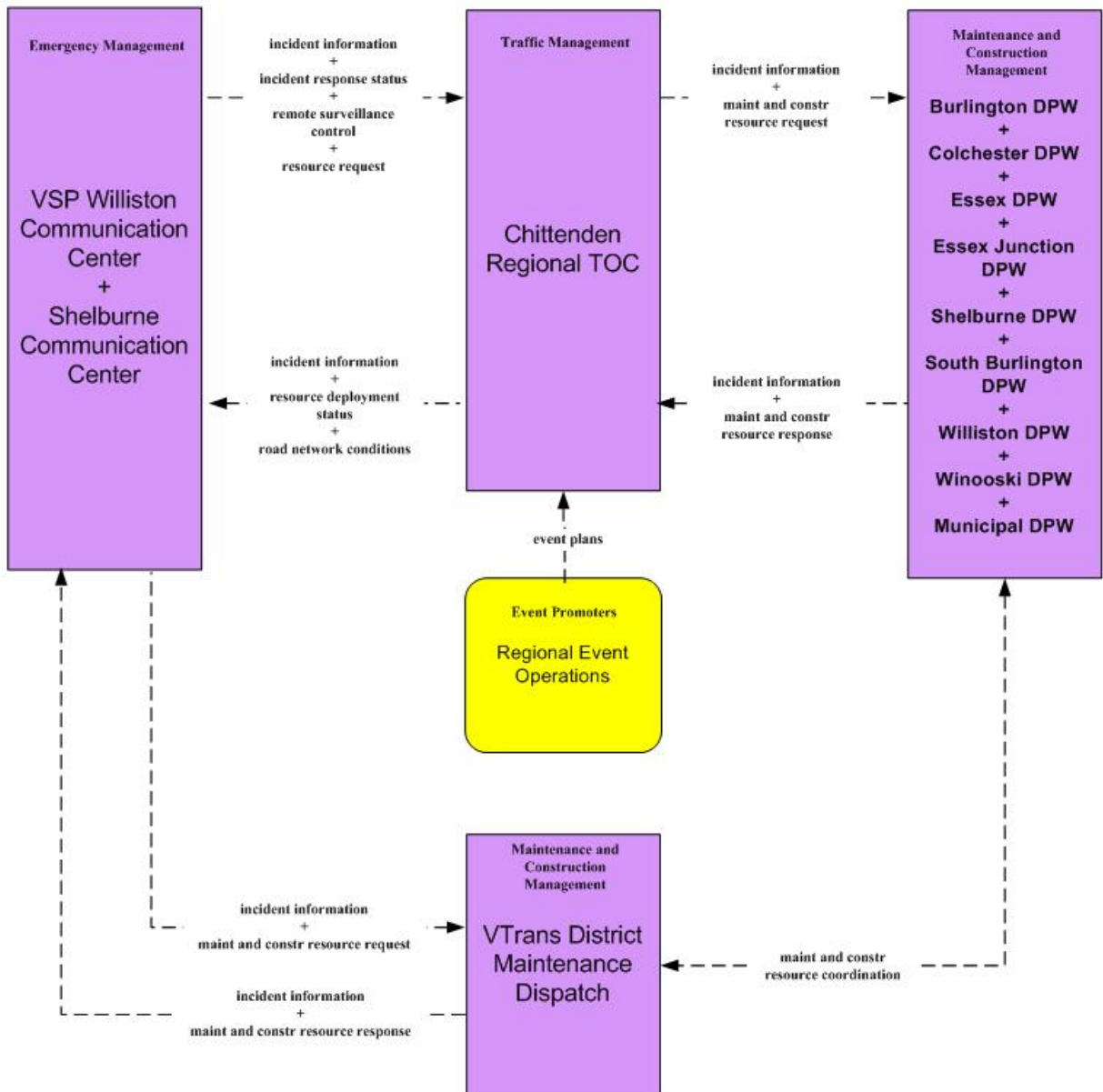

ATMS08 – Incident Management Winooski Traffic Management

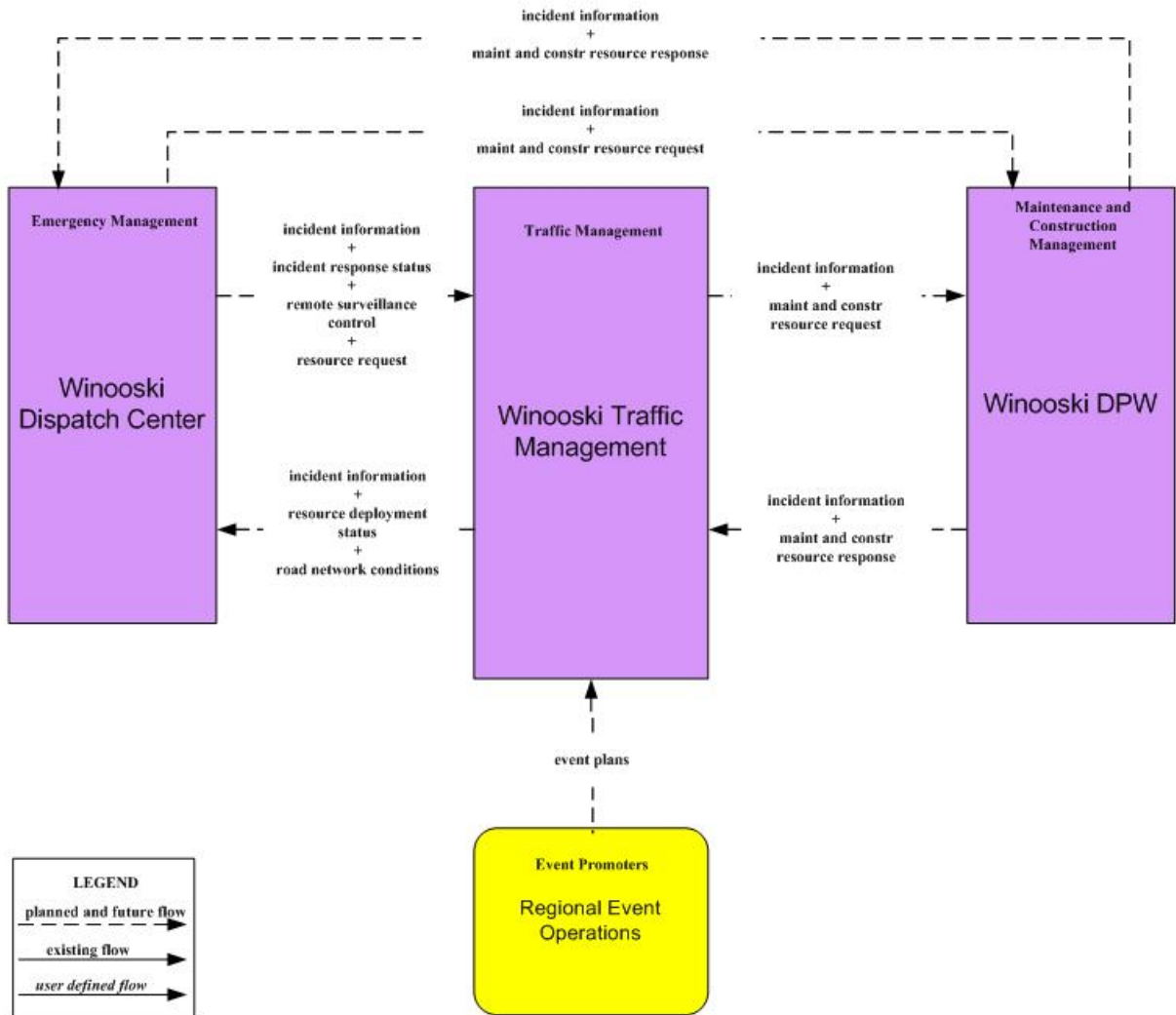

**ATMS13 - Standard Railroad Grade Crossing
Chittenden Regional Traffic Operations Center (Future)**

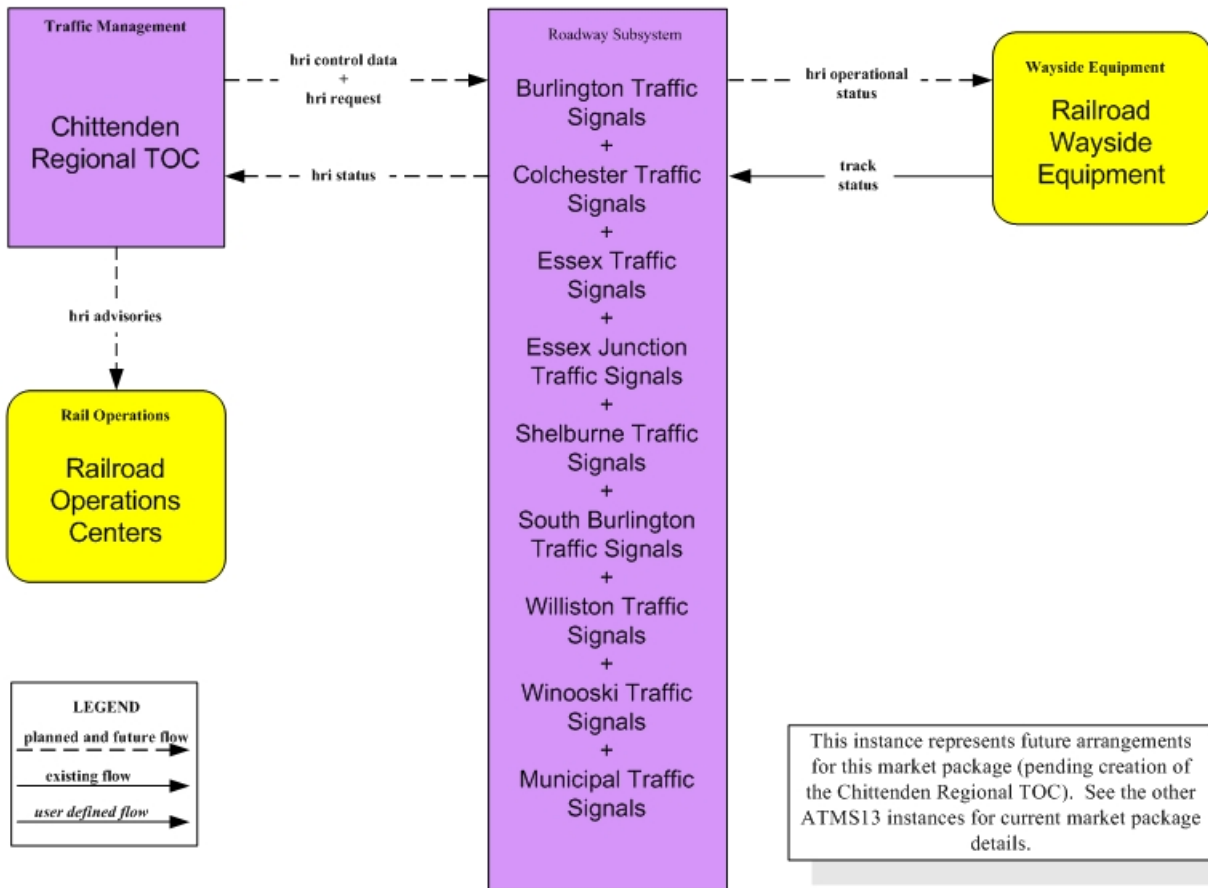

ATMS13 - Standard Railroad Grade Crossing
Winooski Traffic Management

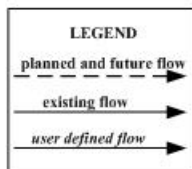
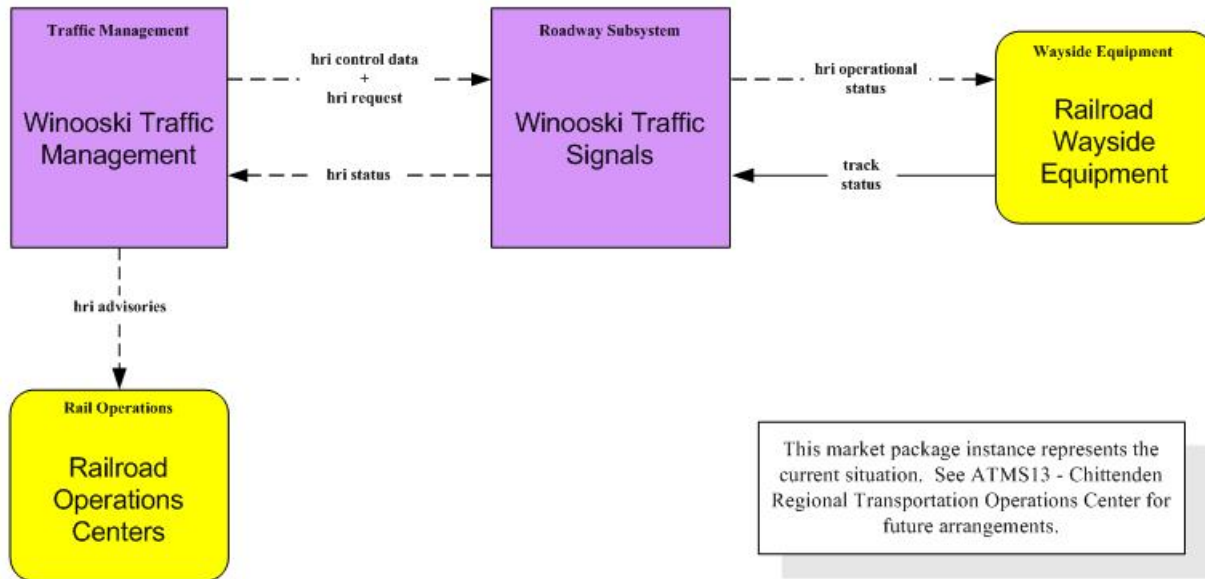

ATMS15 – Railroad Operations Coordination

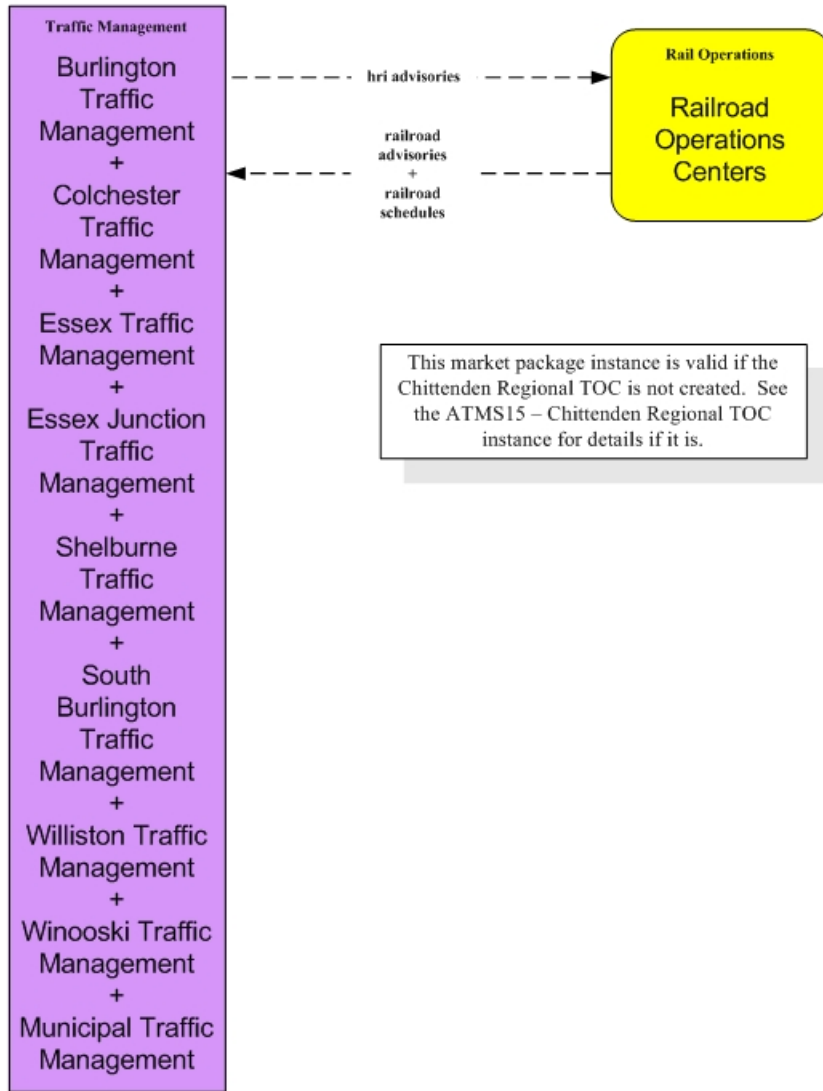

This market package instance is valid if the Chittenden Regional TOC is not created. See the ATMS15 – Chittenden Regional TOC instance for details if it is.

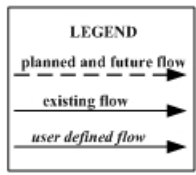

EMO2 – Emergency Routing
1 of 2 - Chittenden Regional TOC

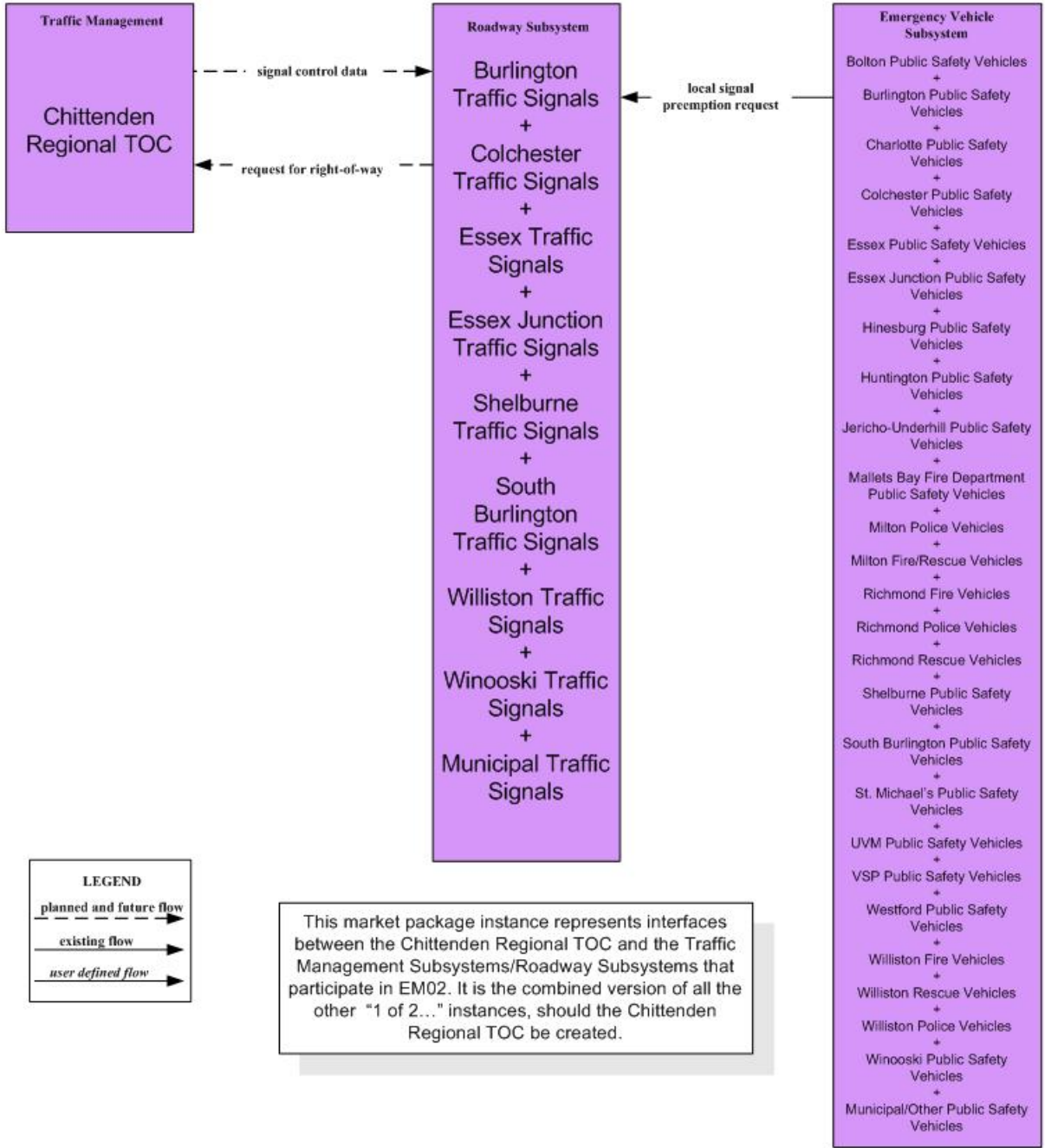

EMO2 – Emergency Routing

2 of 2 – Emergency Management

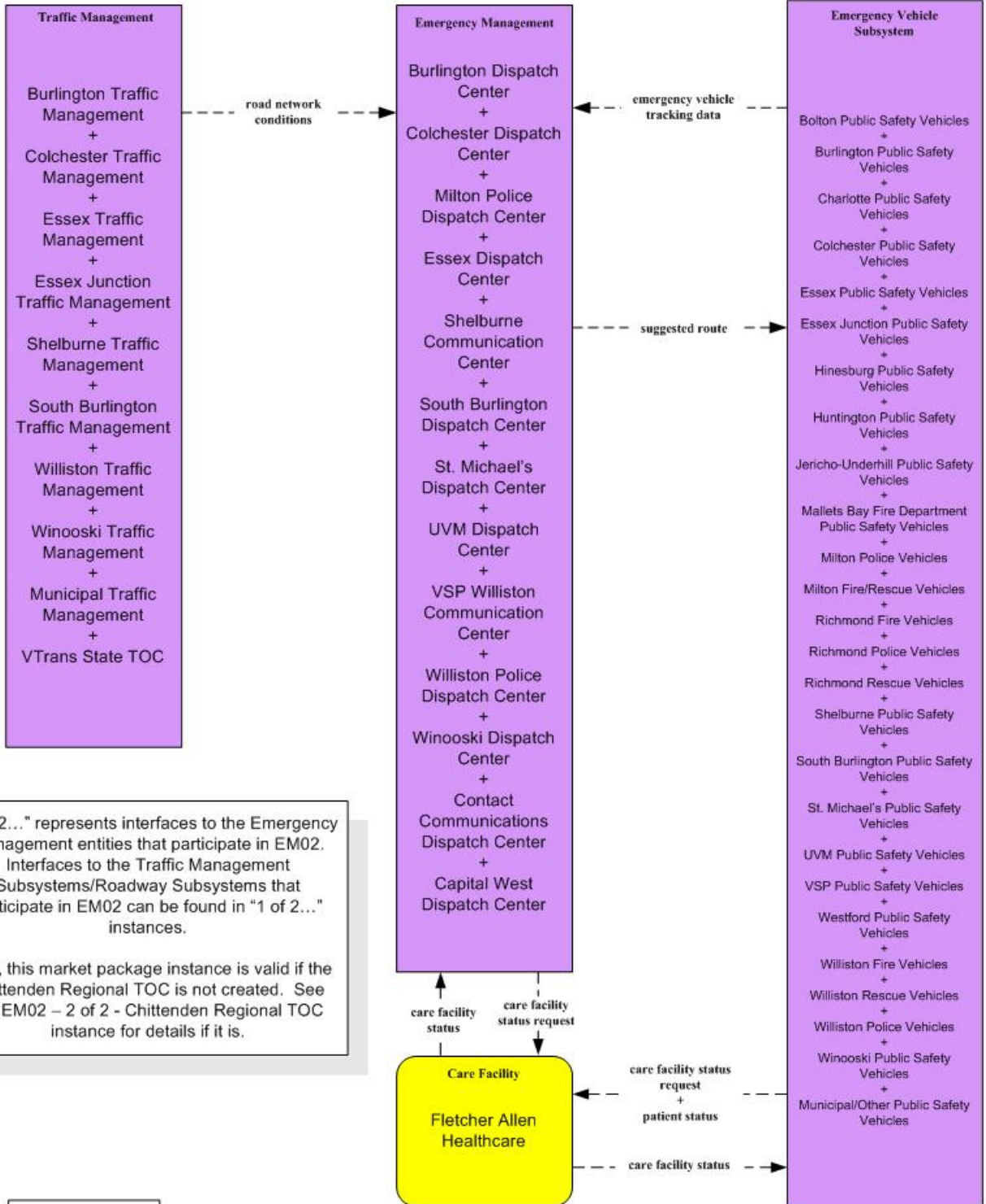

"2 of 2..." represents interfaces to the Emergency Management entities that participate in EM02. Interfaces to the Traffic Management Subsystems/Roadway Subsystems that participate in EM02 can be found in "1 of 2..." instances.

Also, this market package instance is valid if the Chittenden Regional TOC is not created. See the EM02 – 2 of 2 - Chittenden Regional TOC instance for details if it is.

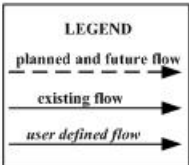

EMO2 – Emergency Routing Winooski

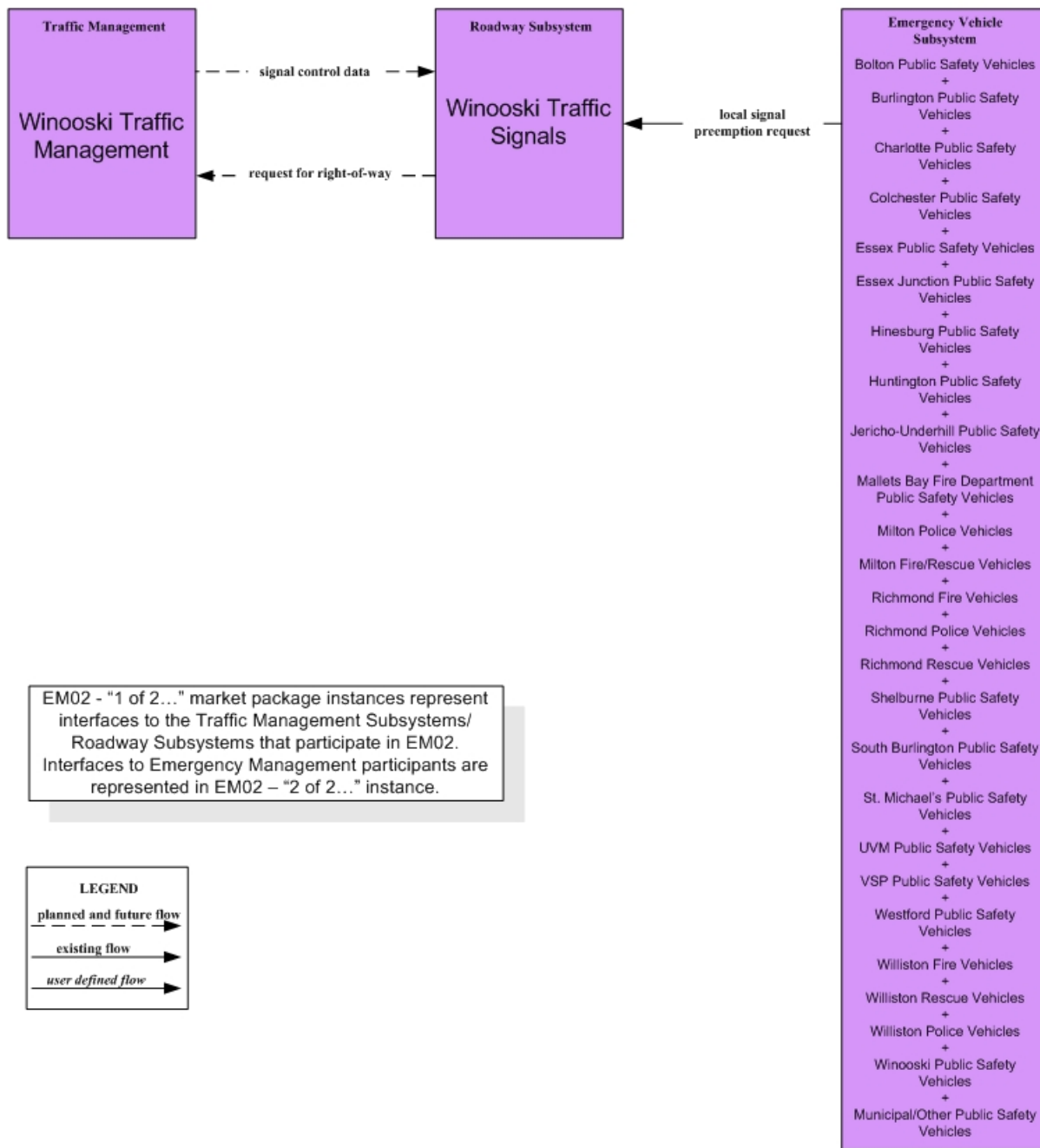

**EMO6 – Wide Area Alert
Vermont Statewide EOC & VSP Headquarters**

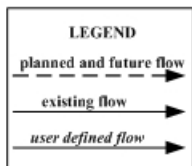
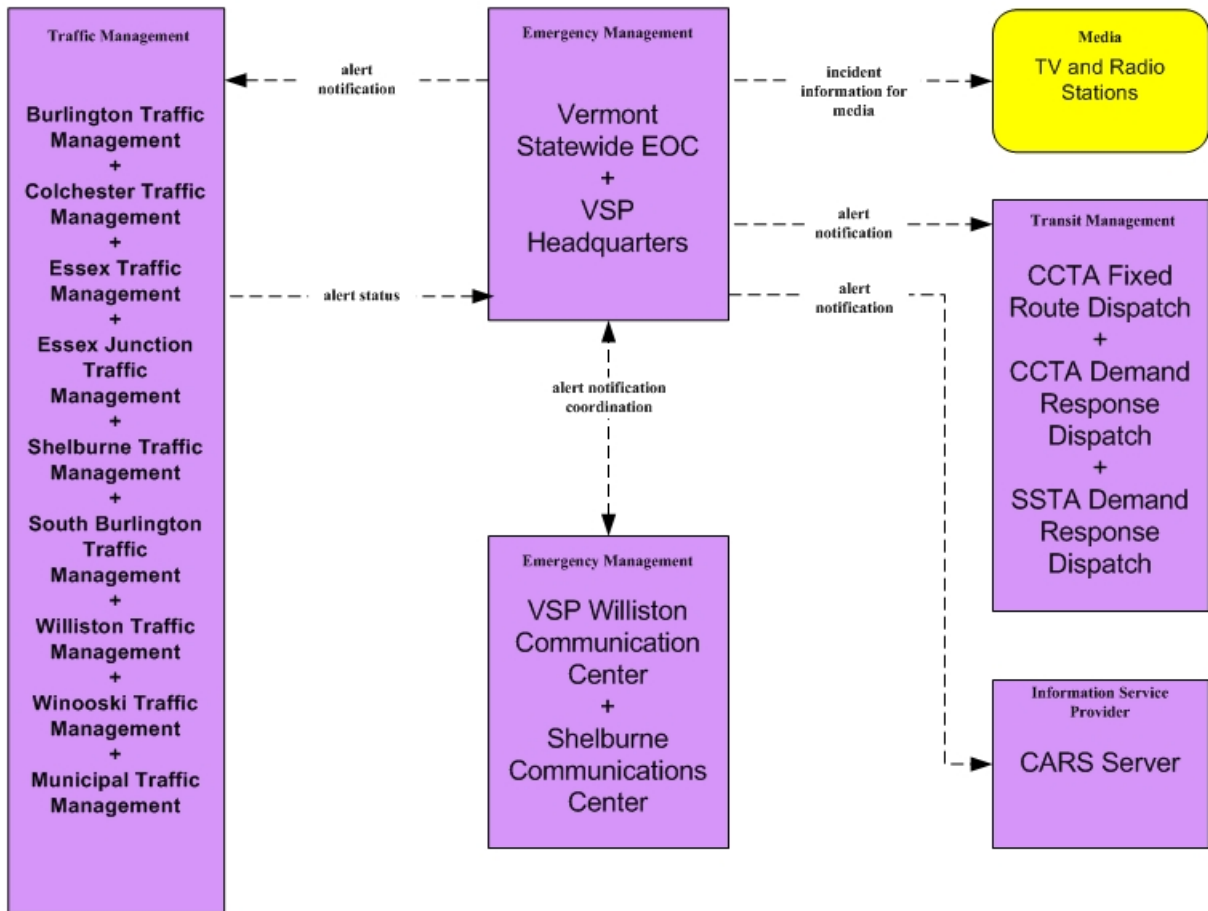

EM09 - Evacuation and Reentry Management
Vermont Statewide EOC

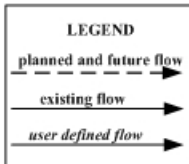
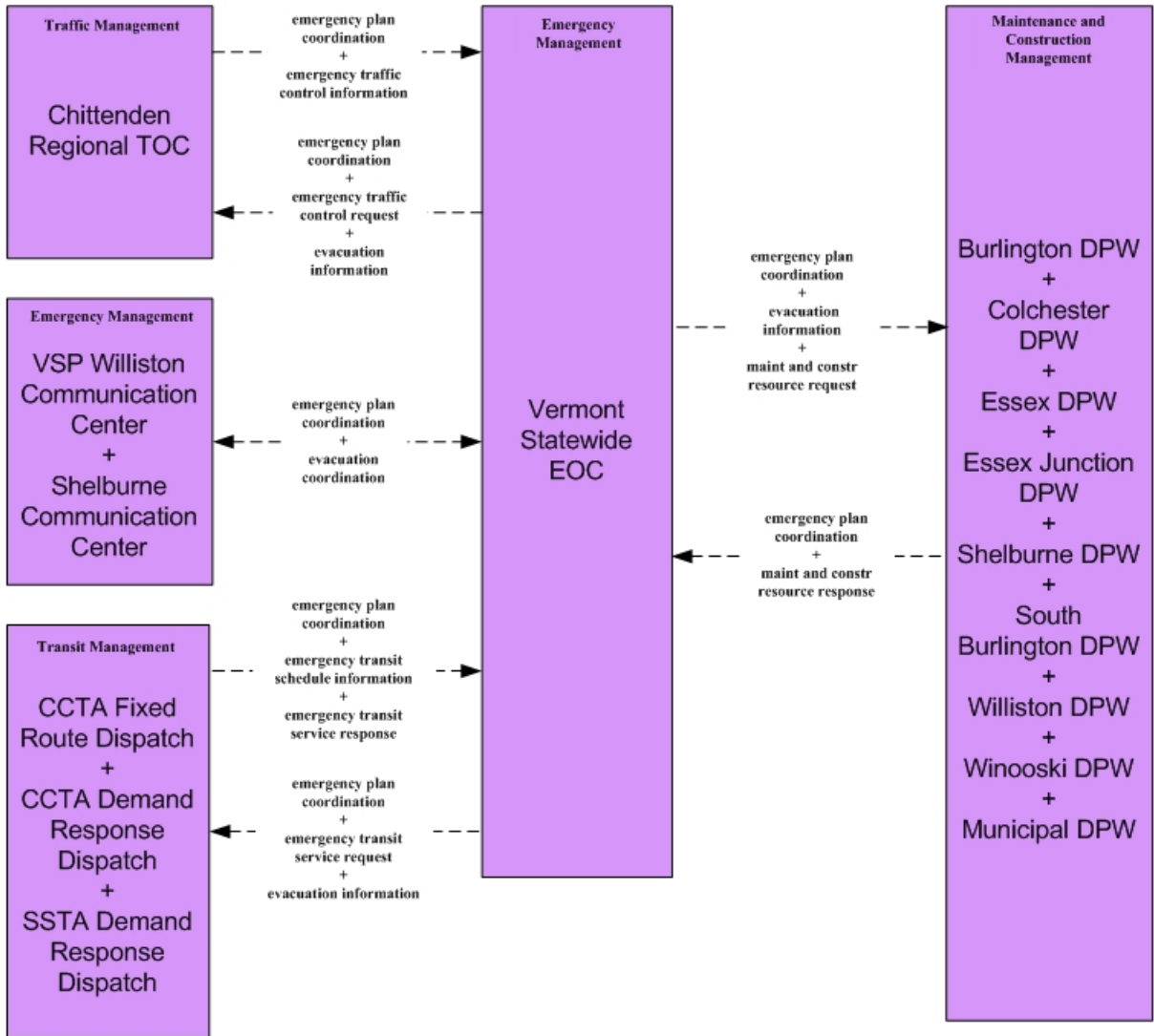

MC01 – Maintenance and Construction Vehicle Tracking
Winooski DPW

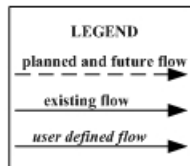
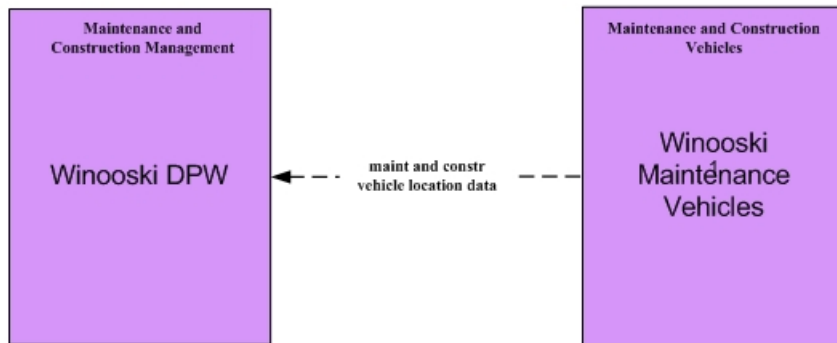

MC02 – Maintenance and Construction Vehicle Maintenance
Winooski DPW

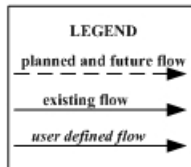
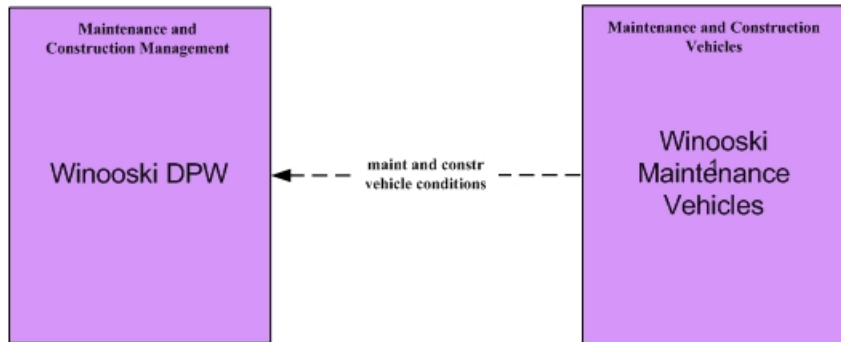

MC04 - Weather Information Processing and Distribution
Weather Services

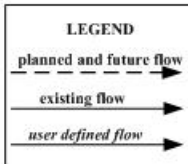
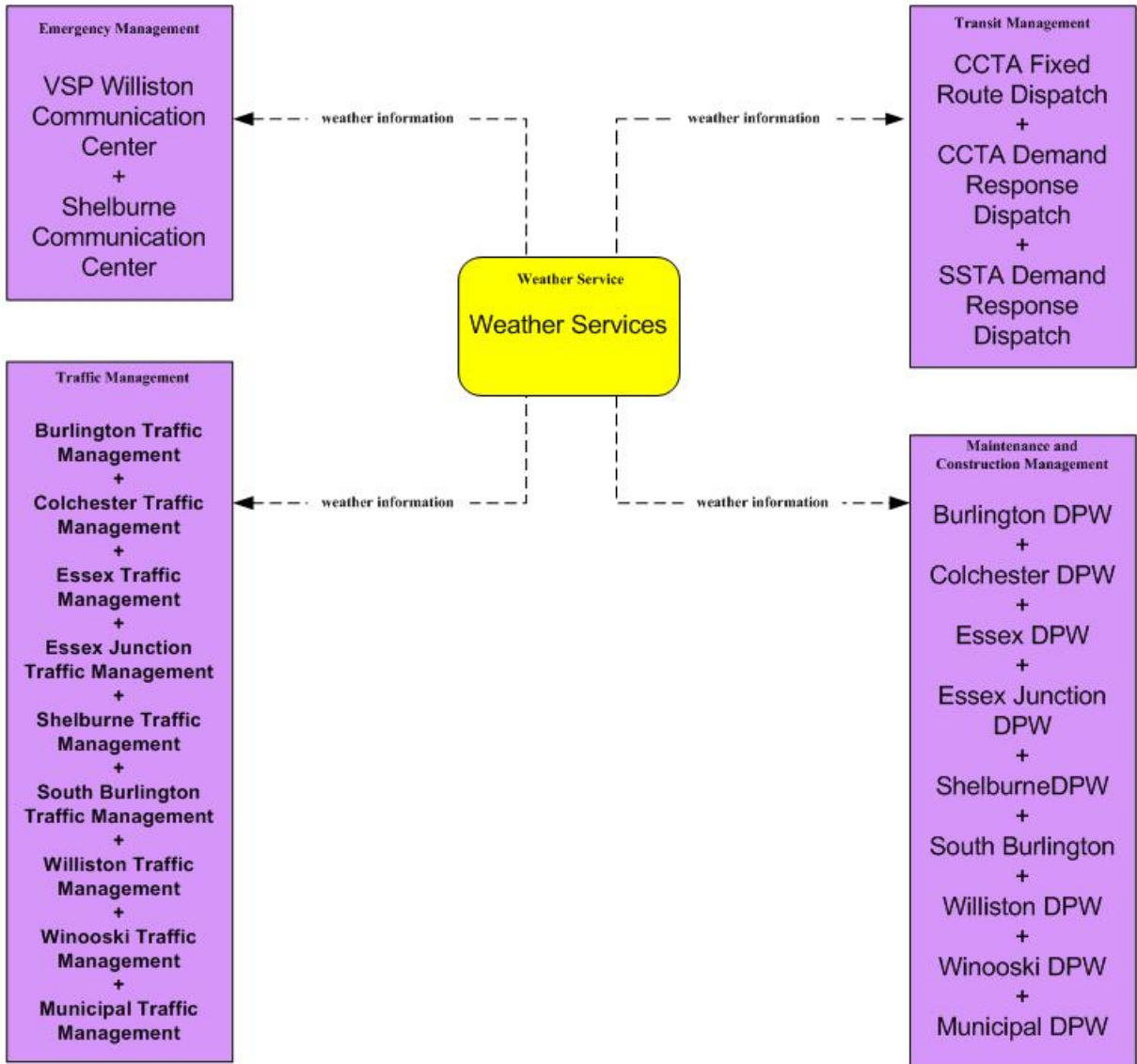

This instance represents the situation for this market package with existing entities only. See the MC04 – Weather Services (Chittenden Regional TOC) instance for market package details pending creation of the Chittenden Regional TOC.

MC04 - Weather Information Processing and Distribution
Weather Services – Chittenden Regional TOC

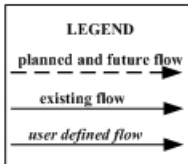
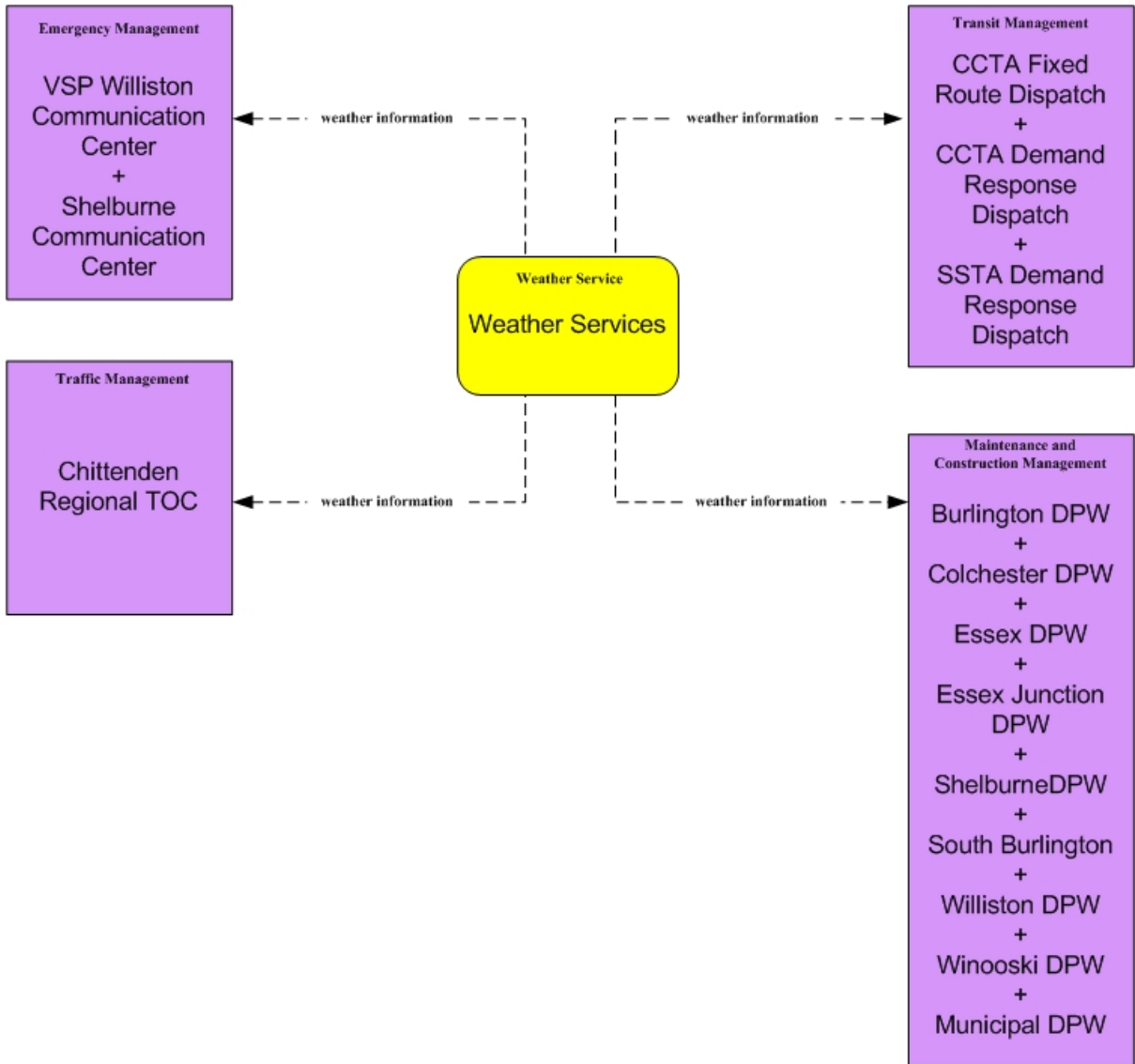

This instance represents the situation for this market package pending creation of the Chittenden Regional TOC. See the MC04 – Weather Services instance for market package details with existing entities only.

MC06 - Winter Maintenance
Winooski DPW

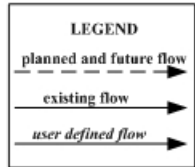
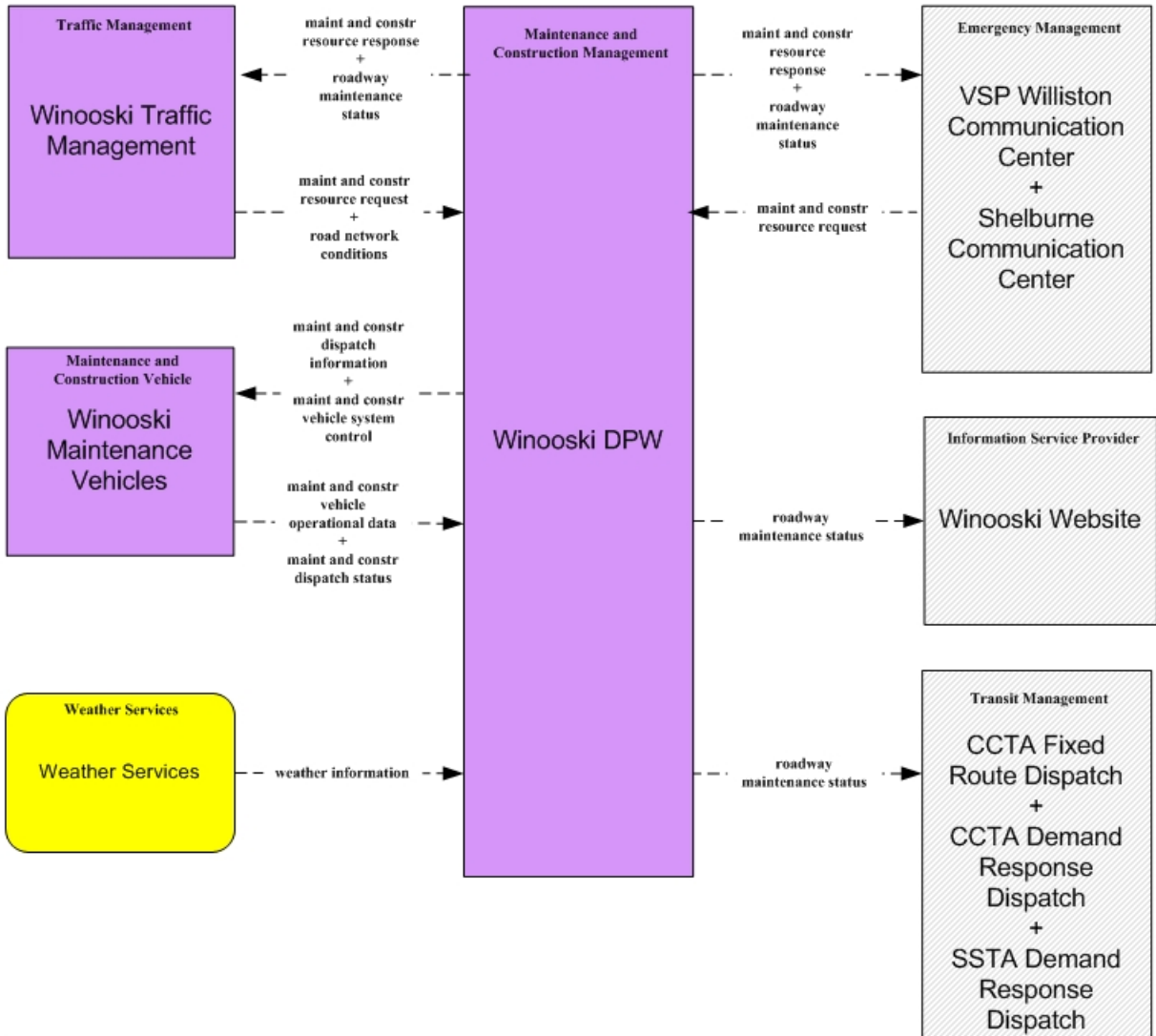

MC07 - Roadway Maintenance and Construction Winooski DPW

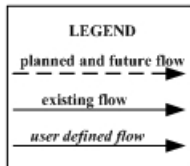
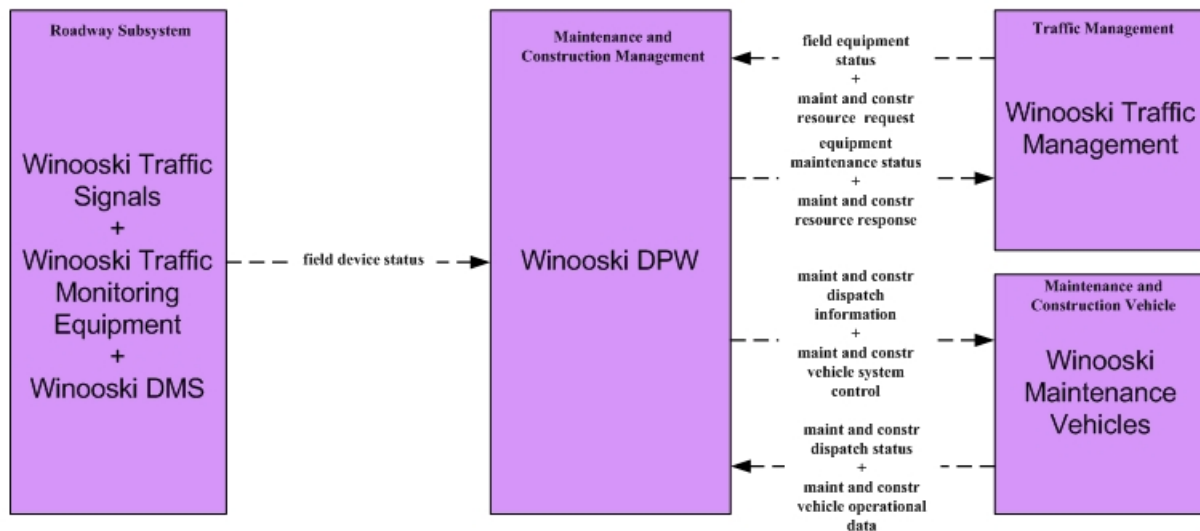

MC08 - Work Zone Management
VTrans District Maintenance Dispatch

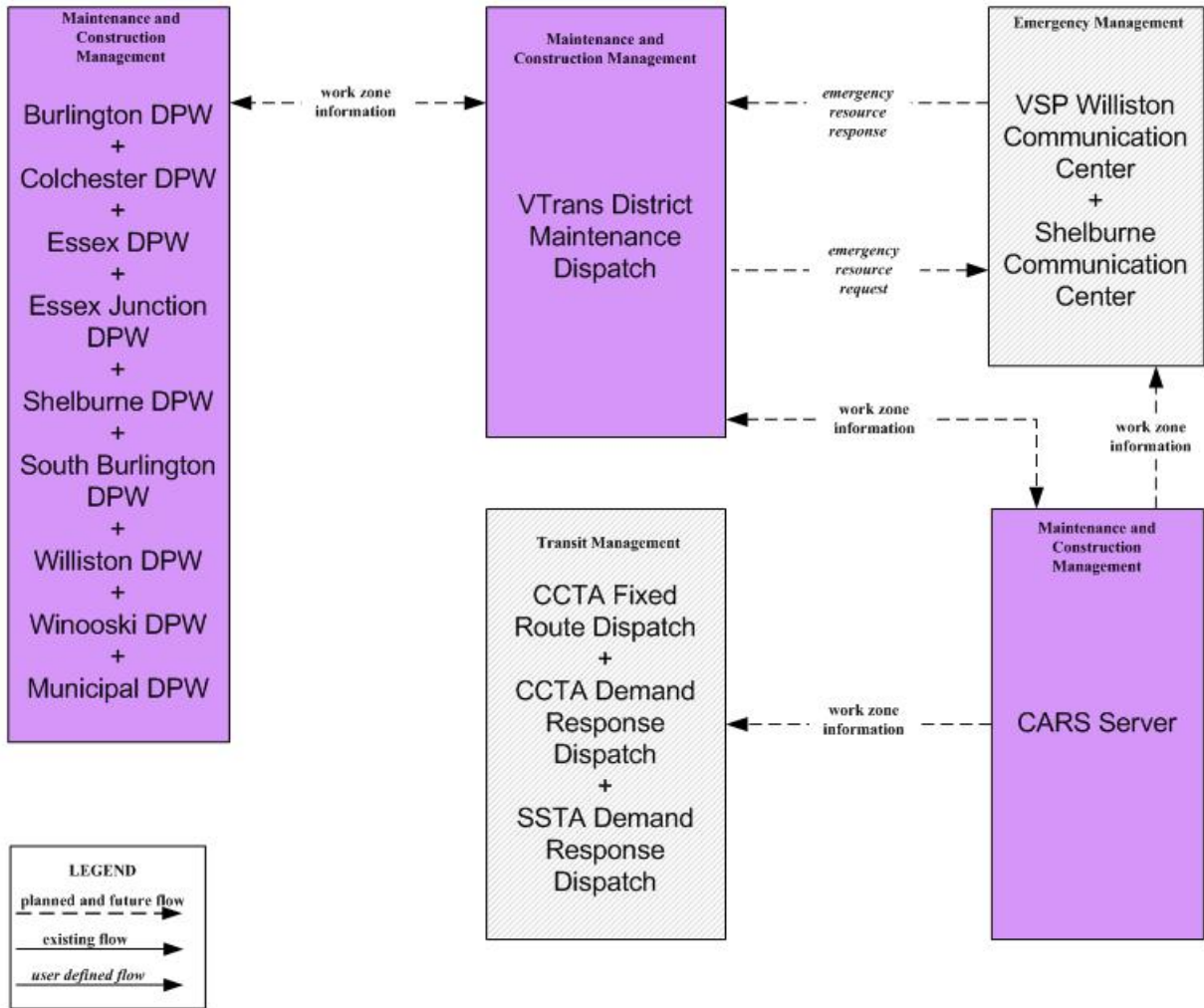

MC08 - Work Zone Management Winooski DPW

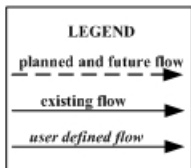
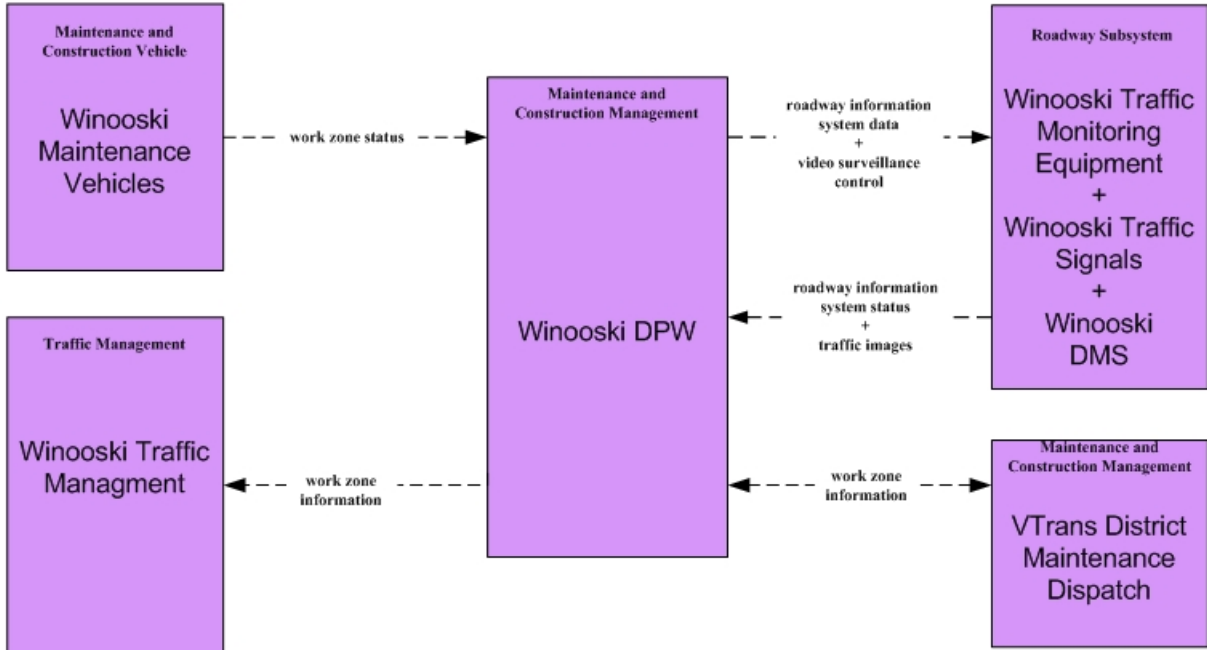

MC10 – Maintenance and Construction Activity Coordination
Winooski DPW

